

PHASED STRATA PLAN OF A PORTION OF LOT A,  
SECTION 23, TOWNSHIP 1, N.W.D., PLAN LMP37657

STRATA PLAN LMS 3841  
PHASE 1

SCALE-1:1000

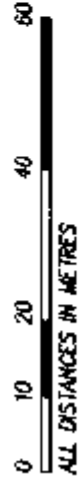

ALL DISTANCES IN METRES

CITY OF SURREY

CIVIC ADDRESS

2588 152nd STREET

DEPOSITED AND REGISTERED IN THE LAND TITLE  
OFFICE AT NEW WESTMINSTER, BRITISH COLUMBIA  
THIS 17th DAY OF MARCH, 1999.

*J. Small / per Du-*  
REGISTERED DEPUTY REGISTRAR  
BN 60560 - BN 66597  
THIS PLAN LIES WITHIN THE  
GREATER VANCOUVER  
REGIONAL DISTRICT

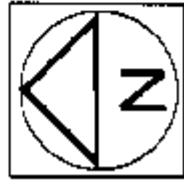

INTEGRATED SURVEY AREA  
No.1 (SURREY) NA083 (CSRS)  
B.C.G.S. 926 006

FORM E - BN66559

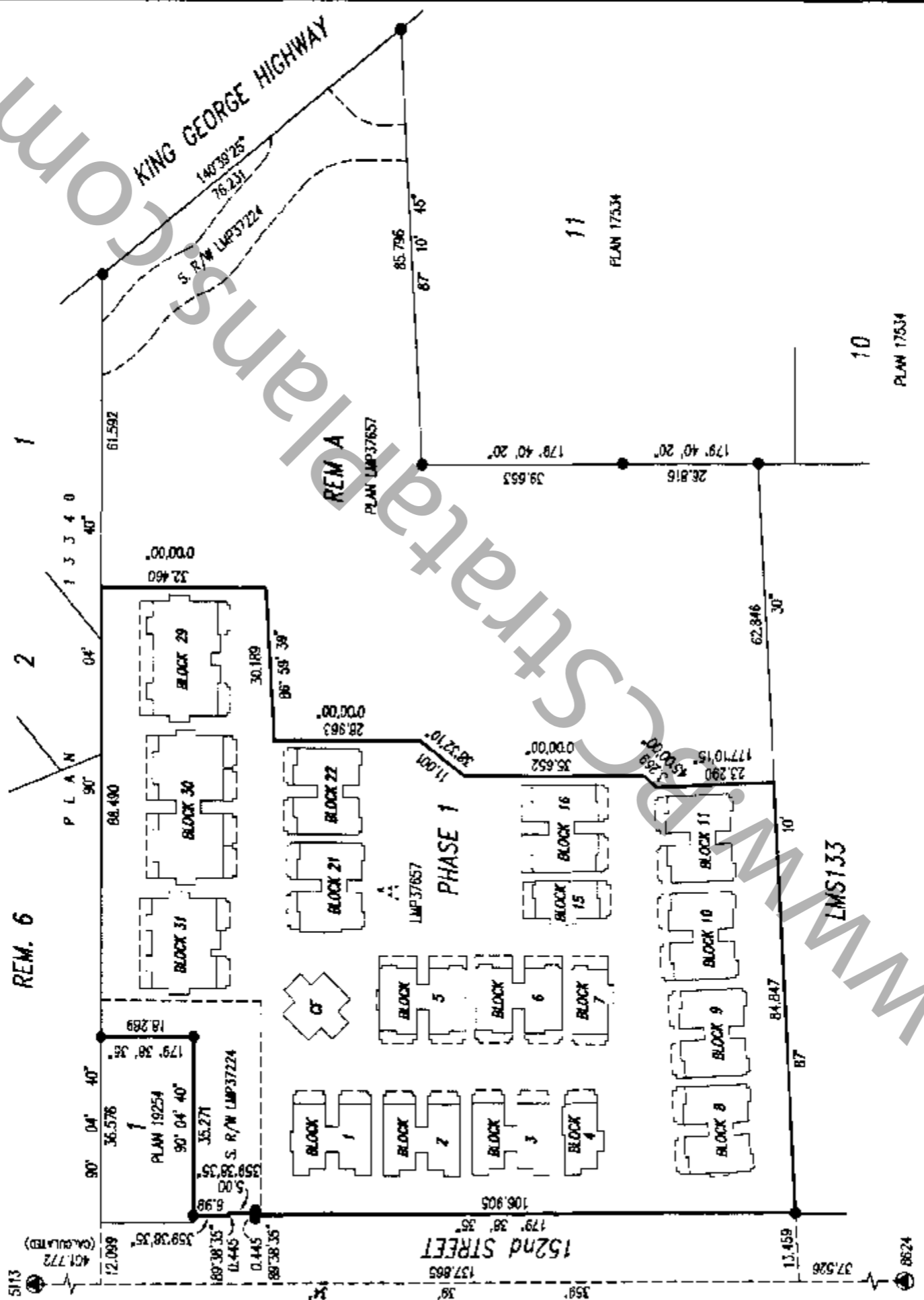

FOR MAILING ADDRESS OF THE  
STRATA CORPORATION SEARCH  
THE STRATA PLAN GENERAL  
INDEX.

THE ADDRESS FOR SERVICE OF DOCUMENTS ON  
THE STRATA CORPORATION IS: THE OWNER'S  
STRATA PLAN LMS 3841

c/o 13520 78th AVENUE  
SURREY, B.C. V3W 8J6

I, G.A. ROMERTHAM, OF THE CITY OF WHITE ROCK  
BRITISH COLUMBIA LAND SURVEYOR, HEREBY  
CERTIFY THAT THE BUILDING ERECTED ON THE  
PARCEL DESCRIBED ABOVE IS WHOLLY WITHIN THE  
EXTERNAL BOUNDARIES OF THAT PARCEL.

*G.A. Romertham*  
B. C. L. S.

DATED AT WHITE ROCK, B.C.

THIS 4th DAY OF FEBRUARY, 1999.

LEGEND

LOP	INDICATES	LIMITED COMMON PROPERTY
Sq.M.	•	SQUARE METRES
SL	•	STRATA LOT
PT	•	PART
©	•	COMMON PROPERTY
D	•	DECK
G	•	GARAGE
M.E.C.H.	•	MECHANICAL ROOM
O.I.B.	•	O.P.L.N. 10 BELOW
ST	•	STORAGE
CF	•	COMMON FACILITY
Y	•	YARD
PK	•	PARKING
E.L.C.C.	•	ELECTRICAL ROOM
•	•	OLD IRON POST FOUND
•	•	OLD LEAD PLUG FOUND
•	•	OLD CONTROL MONUMENT FOUND

THIS PLAN SHOWS GROUND LEVEL MEASURED DISTANCES.  
PRIOR TO COMPUTATION OF UTM COORDINATES, MULTIPLY  
BY THE COMBINED FACTOR 0.9995832.

GRID BEARINGS ARE DERIVED FROM  
OLD CONTROL MONUMENT 8624 AND 5113

SHEET 2 OF 19 SHEETS

# STRATA PLAN LMS 3841

## PHASE 1

# BUILDING FOUNDATION DETAIL

SCALE-1:500

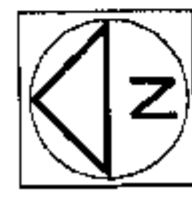

REM. 6  
PLAN 13340

2  
PLAN 13340

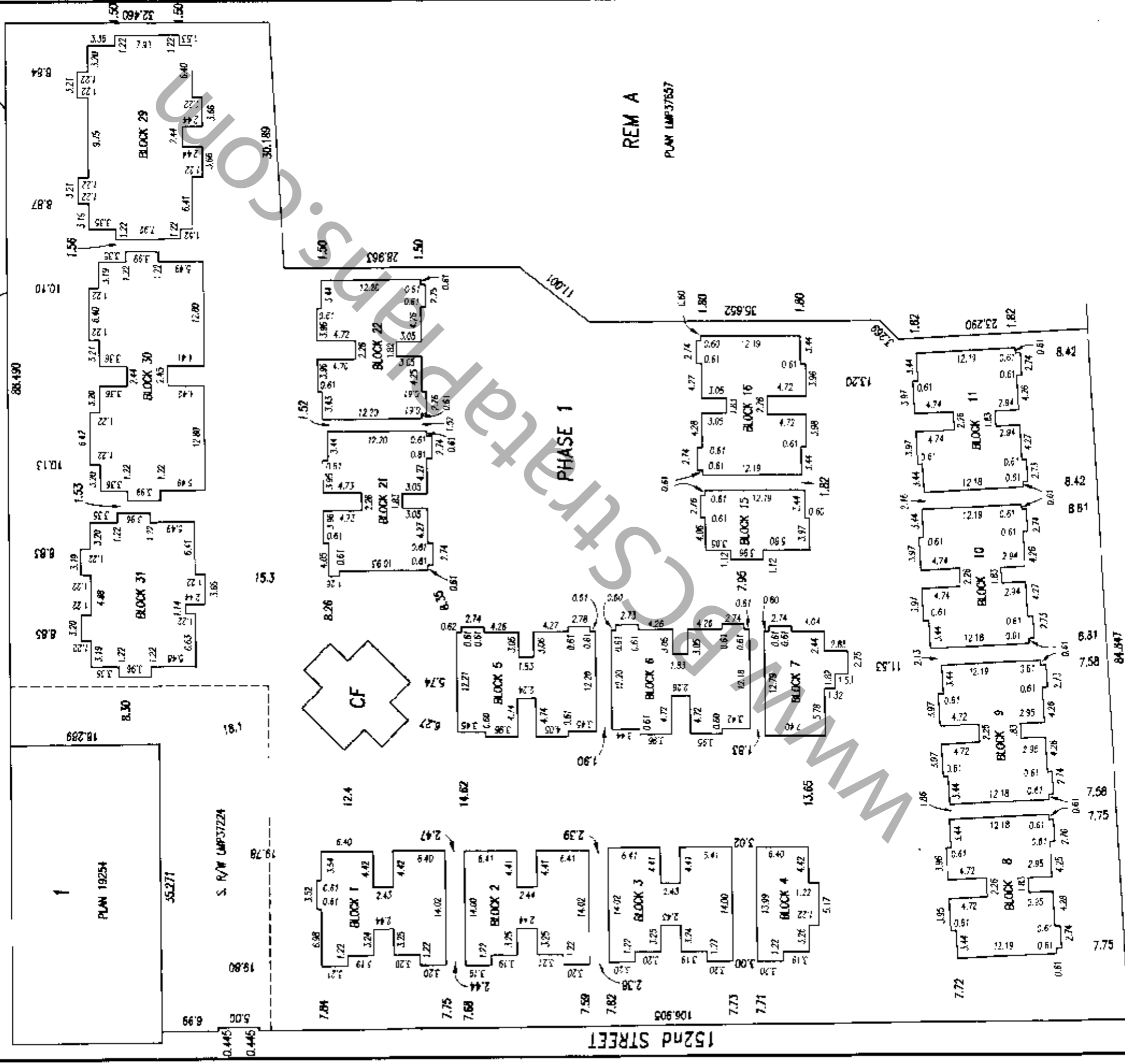

LMS133

G.A.R.

DATED THIS 4th DAY OF FEB. 1999.

B.C.L.S.

# STRATA PLAN LMS 3841

## PHASE 1

### NEW DEVELOPMENT CERTIFICATE

I, G. A. ROMEGRHAM, A BRITISH COLUMBIA LAND SURVEYOR, HEREBY CERTIFY THAT THE BUILDINGS SHOWN IN THIS STRATA PLAN HAVE NOT, AS OF THE 3rd DAY OF FEBRUARY, 1999, BEEN PREVIOUSLY OCCUPIED. DATED AT WHITE ROCK, BRITISH COLUMBIA, THIS 4th DAY OF FEBRUARY, 1999.

### SIGNATURES

#### STATUTORY DECLARATION

WE THE UNDERSIGNED DO SOLEMNLY DECLARE THAT  
(1) WE THE UNDERSIGNED ARE THE OWNER DEVELOPER  
(2) THE STRATA PLAN IS ENTIRELY FOR RESIDENTIAL USE.  
WE MAKE THIS SOLEMN DECLARATION CONSCIENTIOUSLY BELIEVING IT TO BE TRUE AND KNOWING THAT IT IS OF THE SAME FORCE AND EFFECT AS IF MADE UNDER OATH.

Burt Dennis  
Burt Dennis

DECLARED BEFORE ME THIS 16th DAY OF February, 1999

[Signature]  
A COMMISSIONER FOR TAKING AFFIDAVITS WITHIN THE PROVINCE OF BRITISH COLUMBIA  
EDWARD C. WILSON  
1600-925 W. GEORGIA ST.  
VANCOUVER B.C. V6C 3L2  
SOLICITOR

ACCEPTED AS TO FORMS 1, 2 AND 3  
THIS 17th DAY OF March, 1999  
[Signature]  
SUPERINTENDENT OF REAL ESTATE  
SARATHA GALE

APPROVED AS TO PHASE 1 OF A 2 PHASE STRATA PLAN

THIS 10th DAY OF March, 1999  
[Signature]  
APPROVING OFFICER FOR THE CITY OF SURREY

THE CITY OF SURREY AS HOLDER OF COVENANTS BM104309, BM104310, BM104311 AND BM104312 HEREBY CONSENTS TO THE FILING OF THIS STRATA PLAN.

[Signature]  
AUTHORIZED SIGNATORY MARGIE DONG McALLAN  
[Signature]  
AUTHORIZED SIGNATORY CLERK DONNA KENNY

WITNESS:  
ADDRESS AND OCCUPATION OF WITNESS:  
~~\_\_\_\_\_~~  
~~\_\_\_\_\_~~

OWNER: SEMAHMOO LANE DEVELOPMENT LTD.

AUTHORIZED SIGNATORY [Signature]  
Burt Dennis

AUTHORIZED SIGNATORY \_\_\_\_\_

WITNESS: [Signature]  
Edward C. Wilson

ADDRESS AND OCCUPATION OF WITNESS:  
1600-925 W. Georgia St  
Vancouver B.C. V6C 3L2

Lawyer

[Signature]

MORTGAGEE: THE BANK OF NOVA SCOTIA BY ITSELF  
APPOINTED ATTORNEY

AUTHORIZED SIGNATORY D.F. AC066194 e/f  
GEORGE ELLIS HARLATE  
AUTHORIZED SIGNATORY SENIOR VICE PRESIDENT

WITNESS: [Signature]  
DOREEN KAUFF

ADDRESS AND OCCUPATION OF WITNESS:

650 W. GEORGIA STREET  
P.O. Box 11501 - F.H. 34  
VANCOUVER, B.C. V6B 4N7  
SECRETARY

I HEREBY CERTIFY THAT THE COMMON FACILITY (AMENITY BUILDING) WHICH ACCORDING TO FORM E OF THE ACT WAS TO BE CONSTRUCTED IN CONJUNCTION WITH PHASE 1 OF THE DEVELOPMENT HAS BEEN SATISFACTORILY PROVIDED FOR.

DATED THIS 10th DAY OF March, 1999  
[Signature]  
APPROVING OFFICER FOR THE CITY OF SURREY

G.A.R.  
DATED THIS 4th DAY OF FEB., 1999. S.C.L.S.

# STRATA PLAN LMS 3841

## PHASE 1

### CONDOMINIUM ACT

LOT NUMBER	SHEET NUMBER	FORM 1			FORM 2		FORM 3	
		SCHEDULE OF UNIT ENTITLEMENT	SCHEDULE OF INTEREST UPON DESTRUCTION	SCHEDULE OF INTEREST UPON DESTRUCTION	INTEREST UPON DESTRUCTION	SCHEDULE OF VOTING RIGHTS	NUMBER OF VOTES	
1	5	1488	290	290				
2	5	1982	317	317				
3	5	1987	317	317				
4	5	1982	317	317				
5	6	1972	317	317				
6	6	1974	317	317				
7	6	1972	317	317				
8	7	1580	290	290				
9	7	1564	290	290				
10	7	1561	290	290				
11	7	1568	290	290				
12	7	1563	290	290				
13	8	2108	355	355				
14	8	2083	355	355				
15	8	2066	355	355				
16	8	2060	355	355				
17	9	2062	355	355				
18	9	2063	355	355				
19	9	2063	355	355				
20	9	2063	355	355				
21	10	1548	290	290				
22	10	1569	290	290				
23	10	1589	290	290				
24	11	2100	355	355				
25	11	2076	355	355				
26	11	2063	355	355				
27	11	2067	355	355				
28	12	1438	290	290				
29	12	1524	280	280				
30	12	1442	290	290				
31	13	1437	290	290				
32	13	1453	290	290				
33	13	1452	290	290				
34	13	1438	290	290				
35	14	1440	290	290				
36	14	1542	280	280				
37	14	1540	280	280				
38	14	1440	290	290				
AGGREGATE		66,909	11,932					

G.A.R.

B.C.L.S.

DATED THIS 4<sup>th</sup> DAY OF FEB. 1999.

# FLOOR PLANS

# STRATA PLAN LMS 3841

## PHASE 1



### BLOCK 1

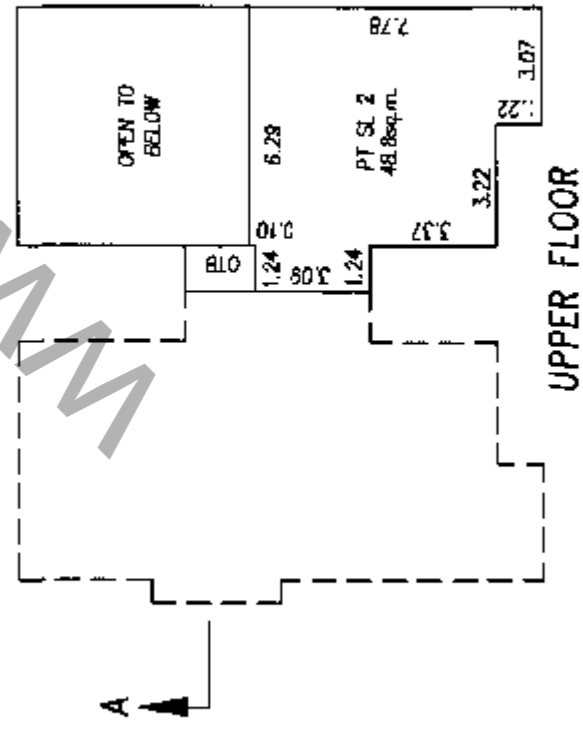
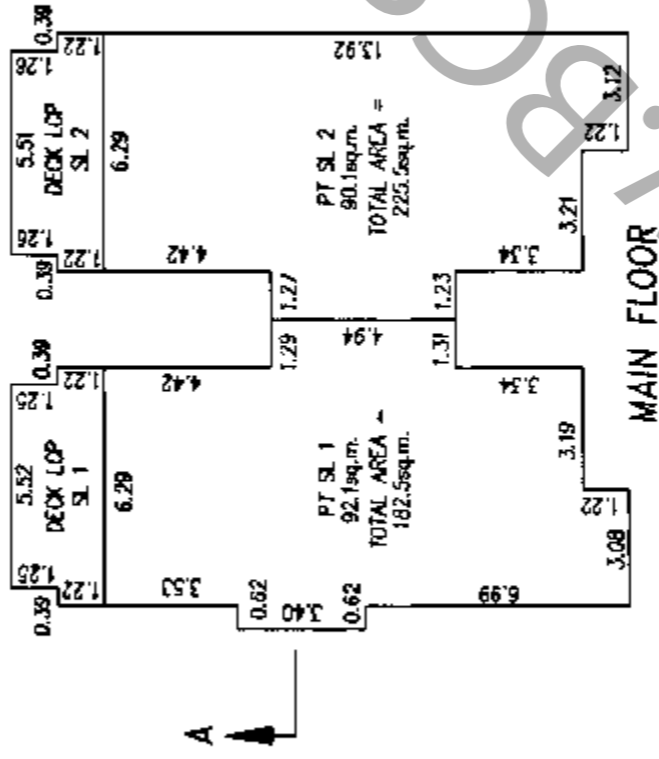
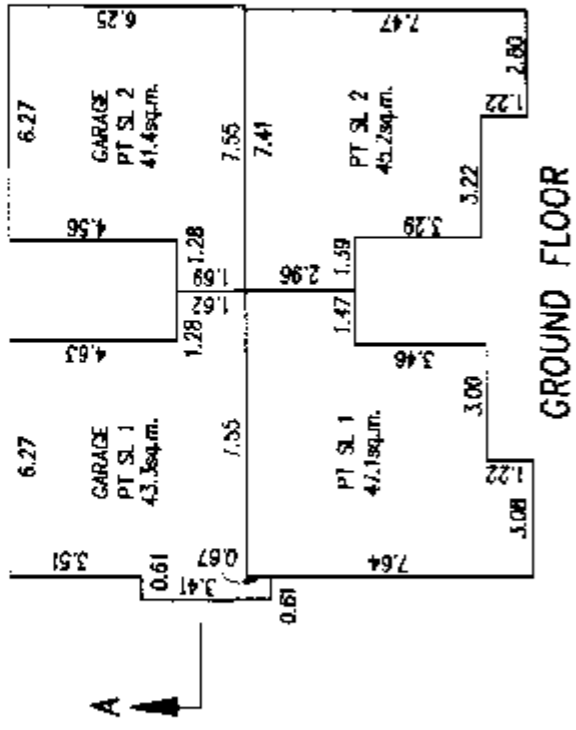

### BLOCK 2

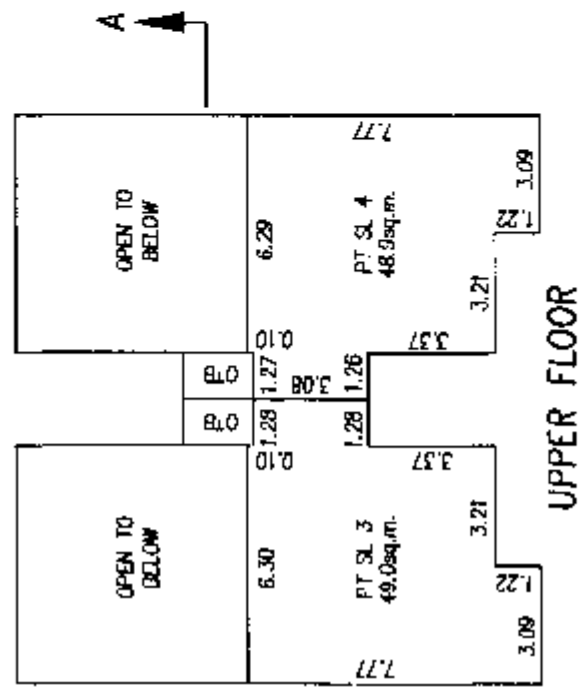
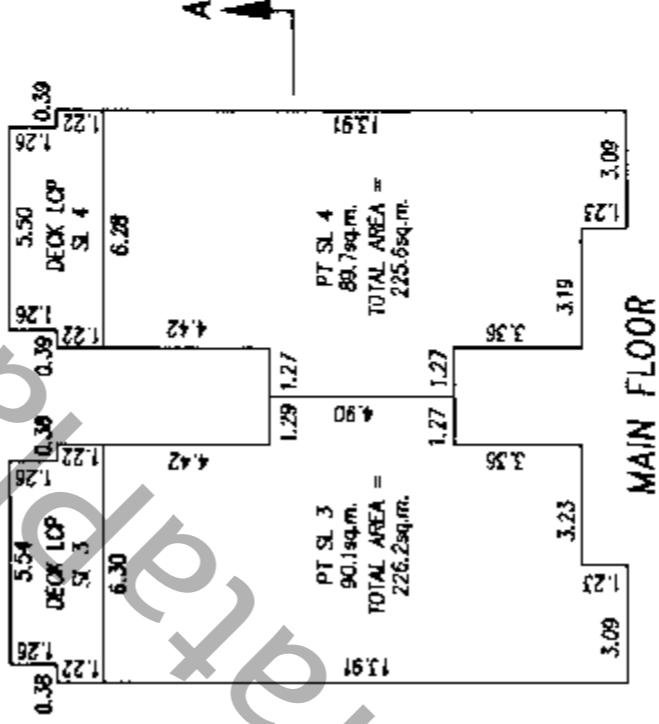
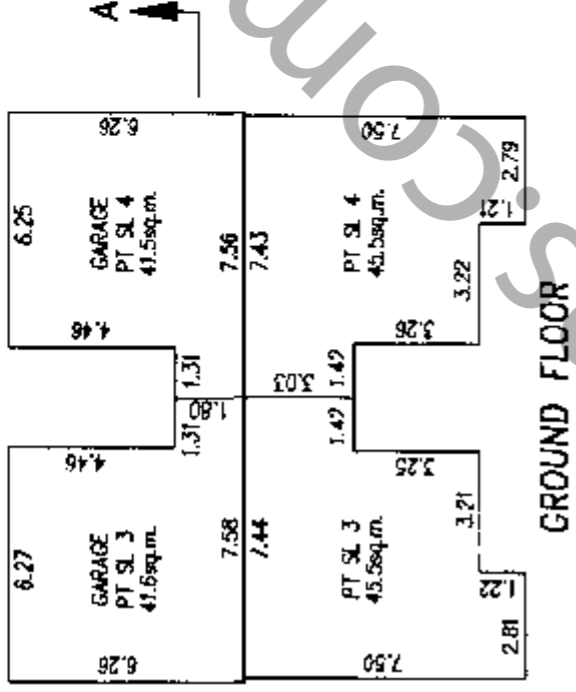

G.A.R.

DATED THIS 4<sup>th</sup> DAY OF FEB 1999. B.C.L.S.

# FLOOR PLANS

# STRATA PLAN LMS 3841

SCALE 1:200



ALL DISTANCES IN METRES



## PHASE 1

### BLOCK 3

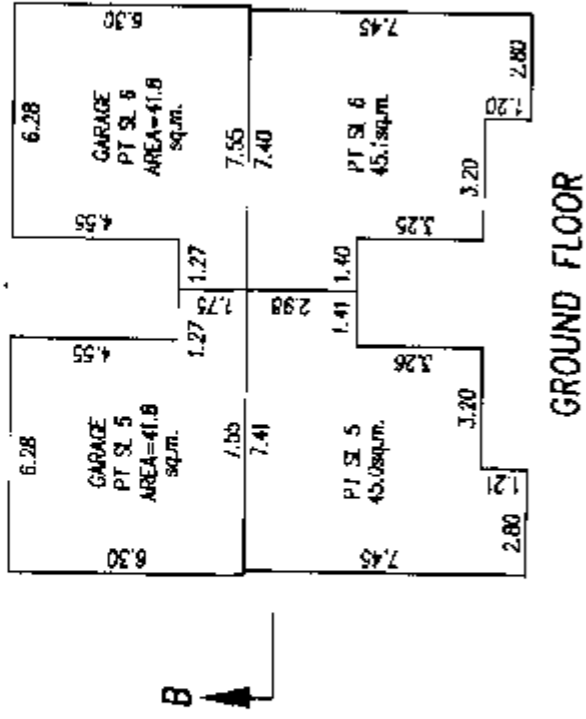

### BLOCK 4

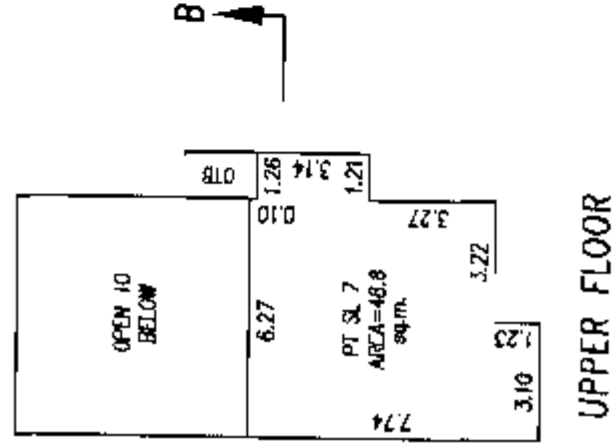
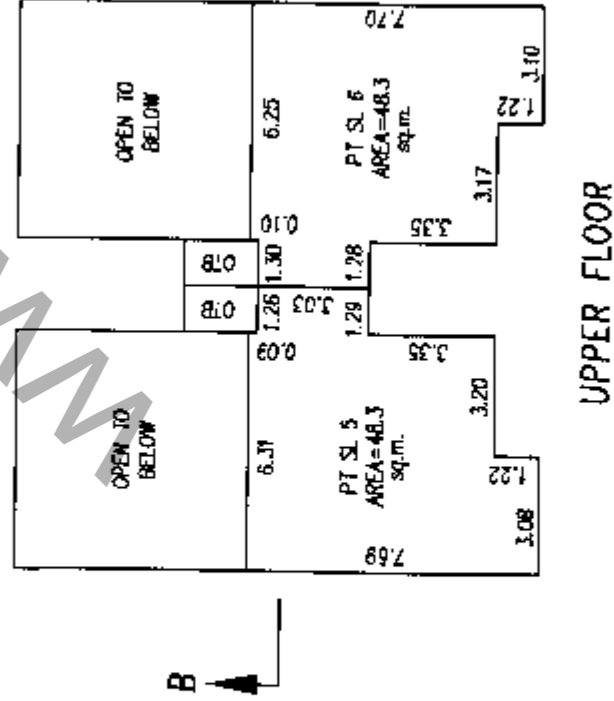
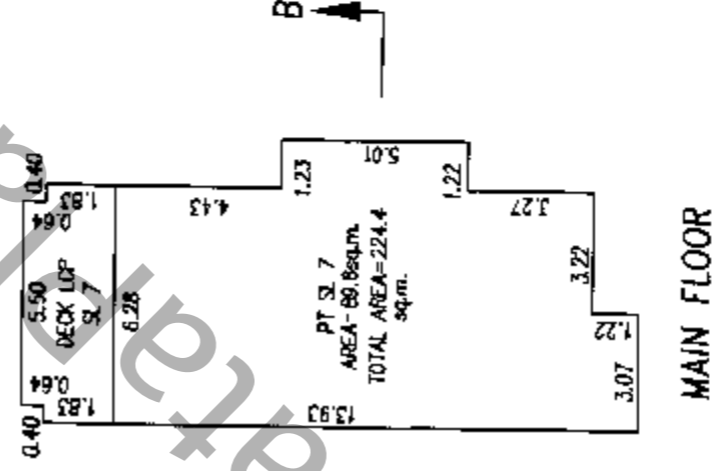
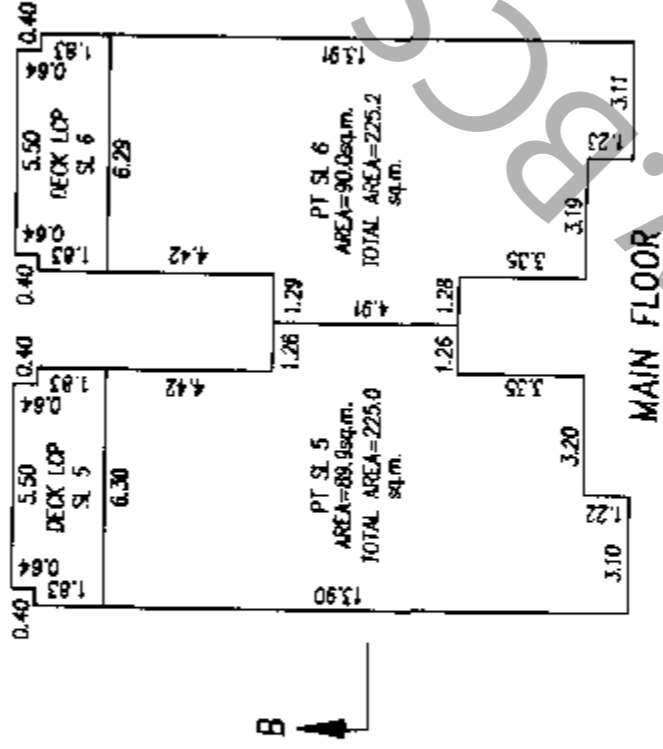
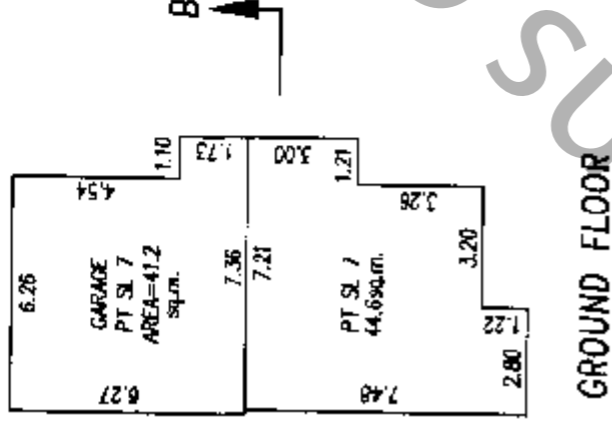

G.A.R.

DATED THIS 4<sup>th</sup> DAY OF FEB. 1999

B.C.L.S.

# FLOOR PLANS

# STRATA PLAN LMS 3841

SCALE 1:200



ALL DISTANCES IN METRES

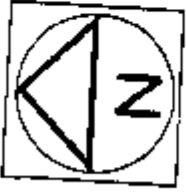

## BLOCK 5

## PHASE 1

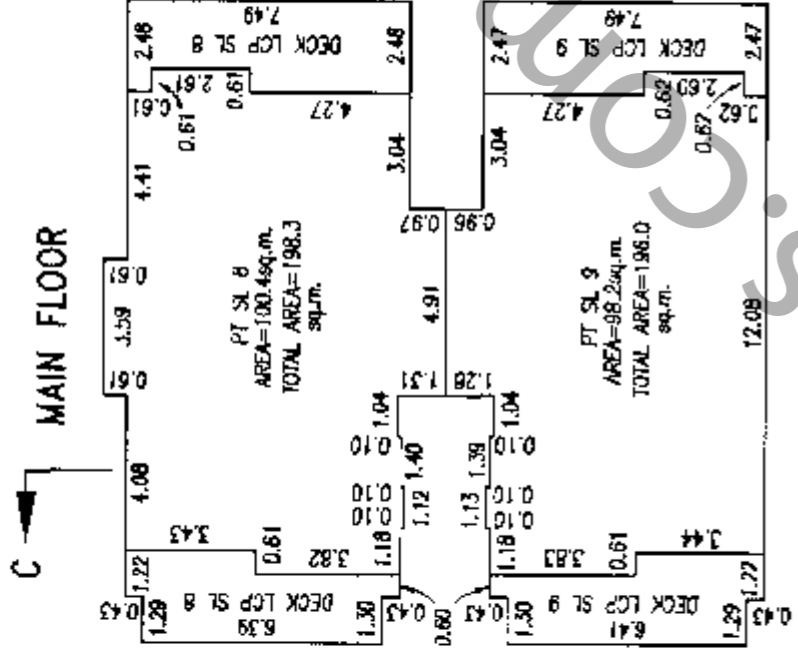
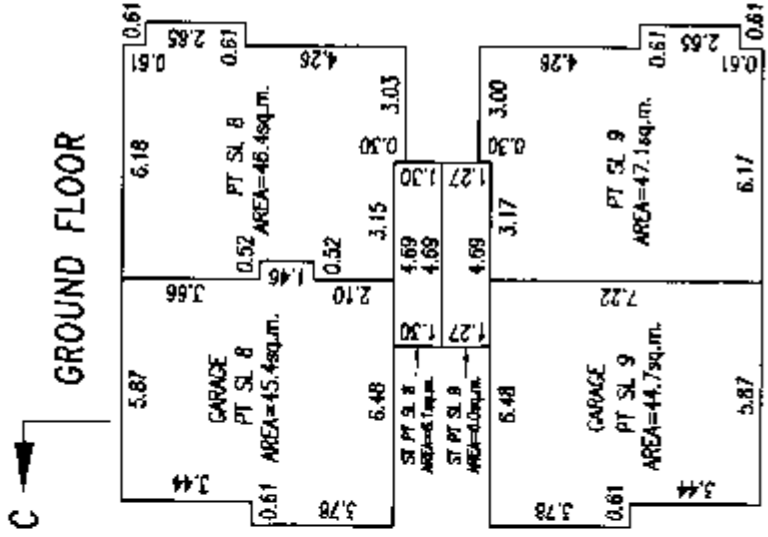

## BLOCK 6

### GROUND FLOOR

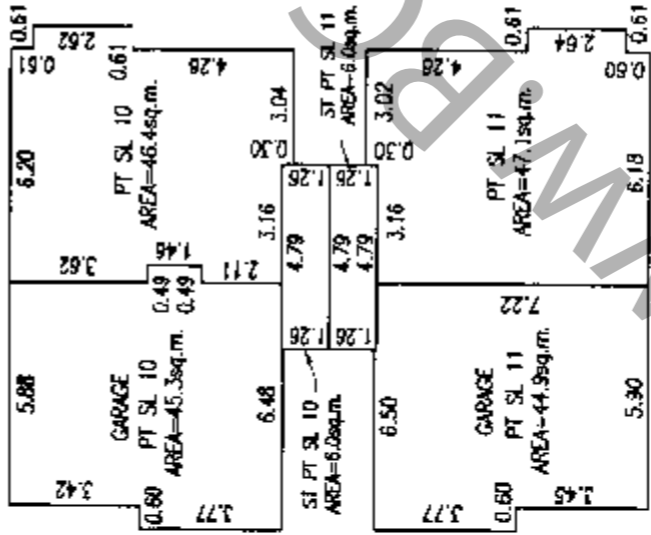

### MAIN FLOOR

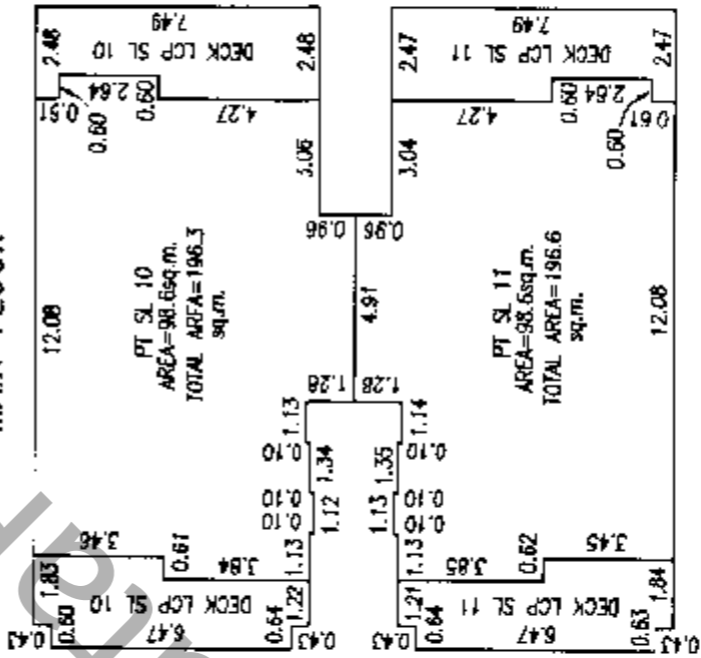

## BLOCK 7

### GROUND FLOOR

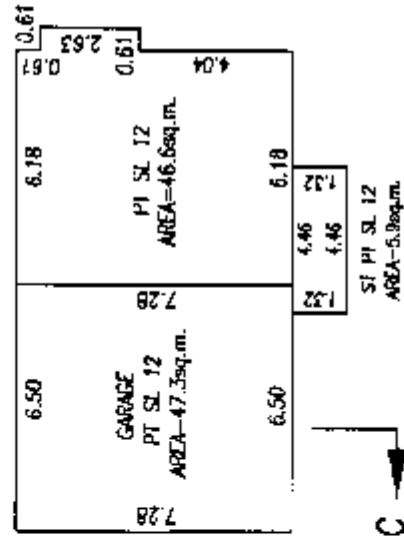

### MAIN FLOOR

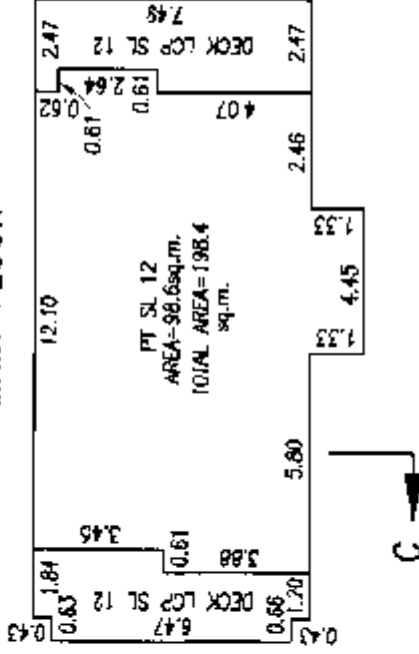

# G.A.R.

# FLOOR PLANS

# STRATA PLAN LMS 3841

SCALE 1:200



ALL DISTANCES IN METRES

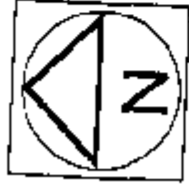

## PHASE 1

### BLOCK 8

### BLOCK 9

#### GROUND FLOOR

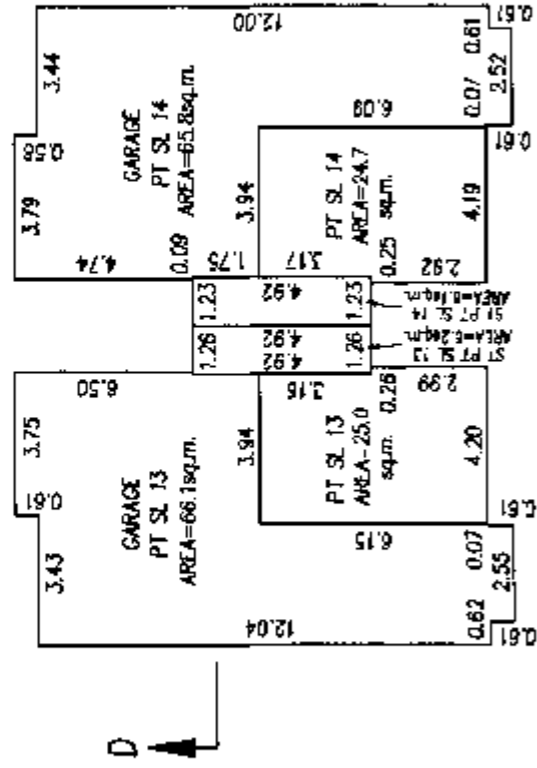

#### GROUND FLOOR

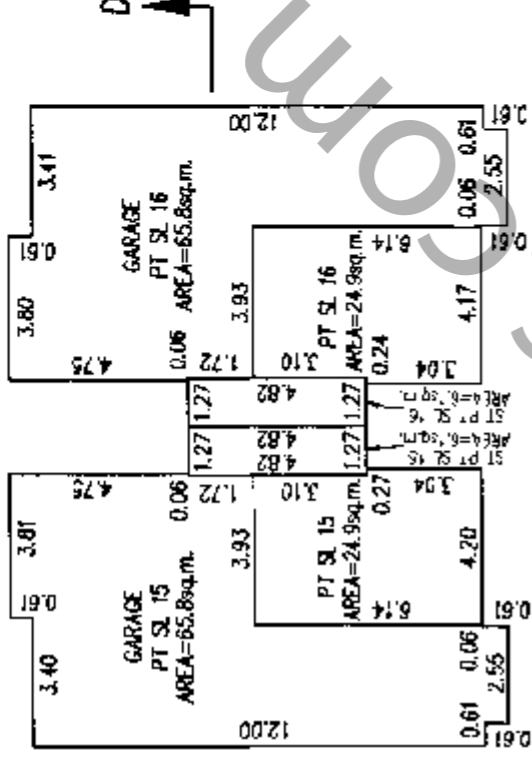

#### MAIN FLOOR

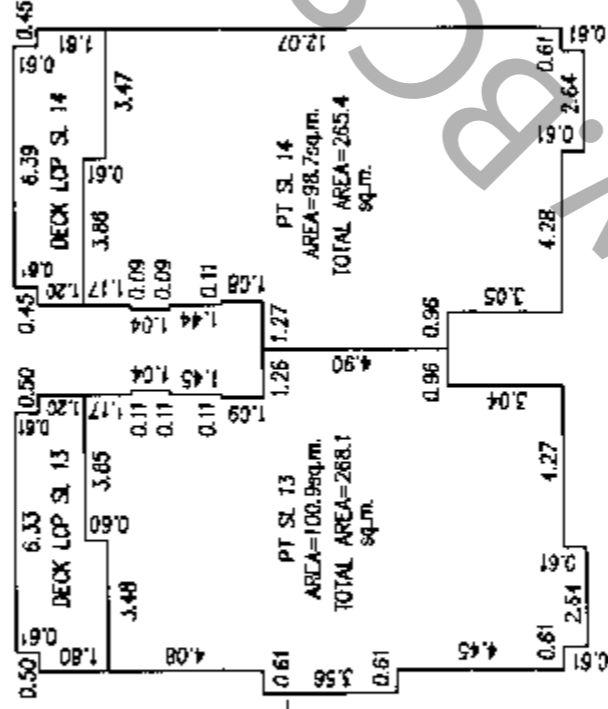

#### MAIN FLOOR

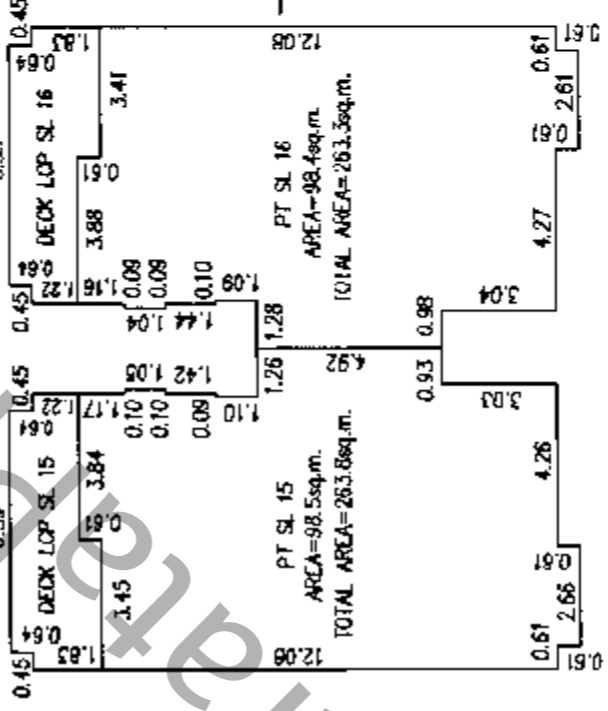

#### UPPER FLOOR

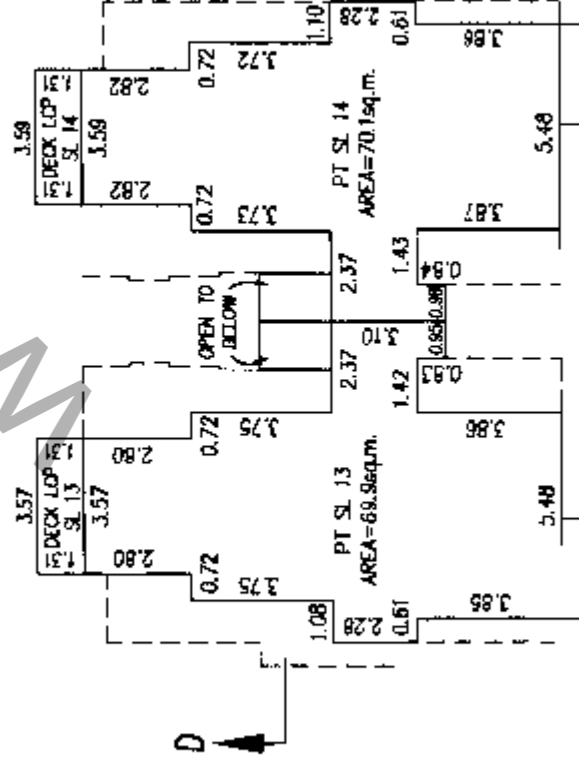

#### UPPER FLOOR

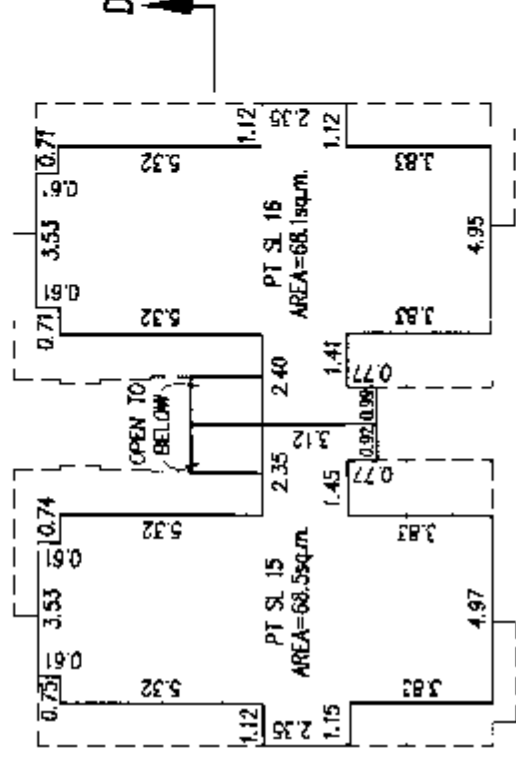

G.A.R.

DATED THIS 4<sup>th</sup> DAY OF FEB. 1999

B.C.L.S.



# STRATA PLAN LMS 3841

## PHASE 1

SCALE 1:200  
0 5 10 15  
ALL DISTANCES IN METRES

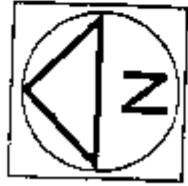

### BLOCK 10

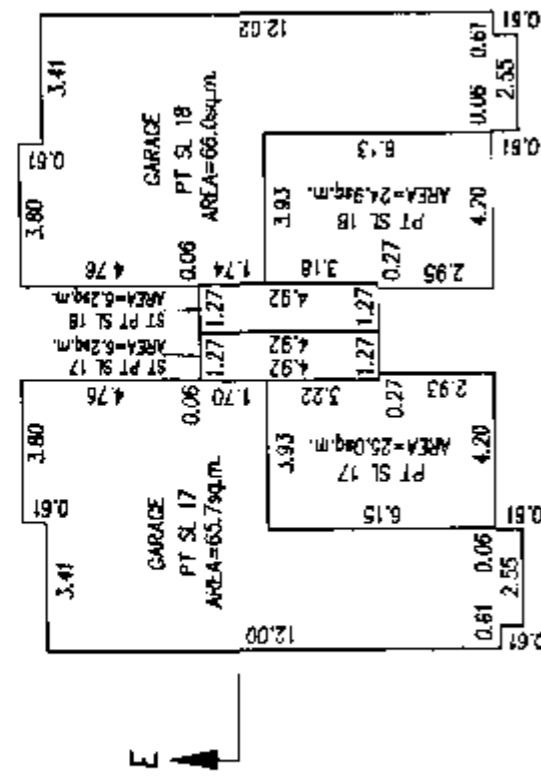

### BLOCK 11

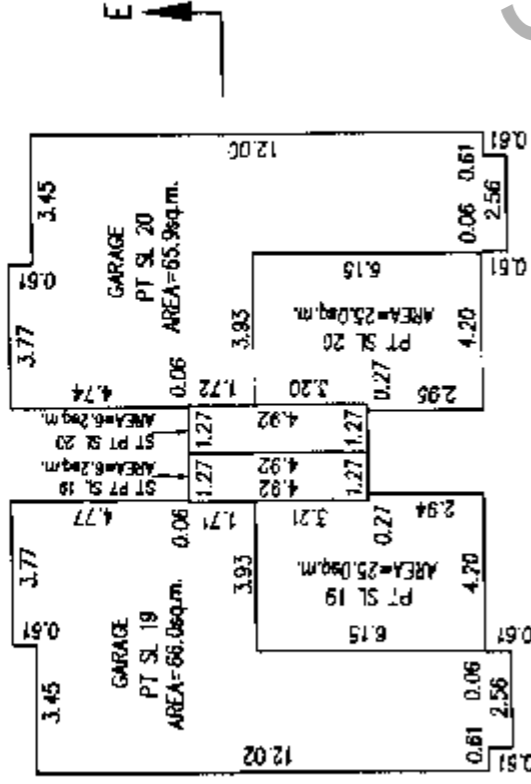

### GROUND FLOOR

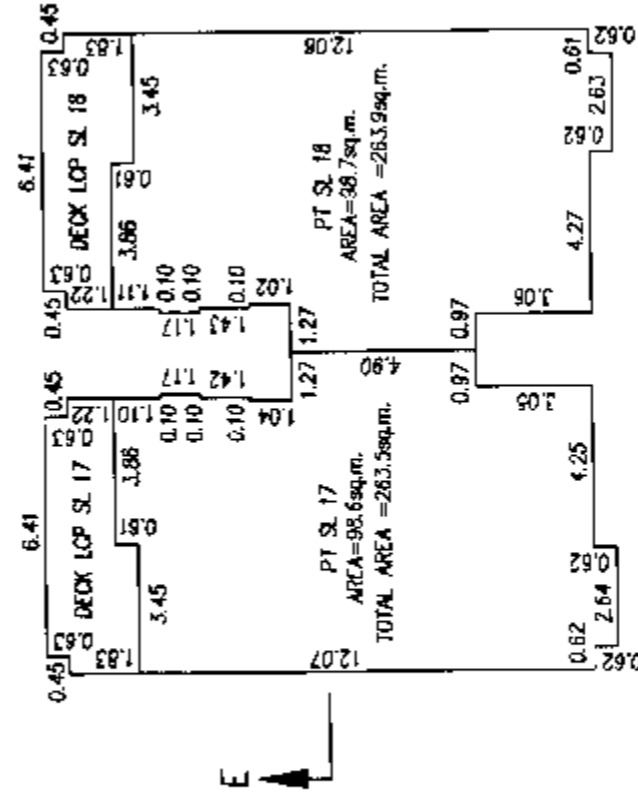

### GROUND FLOOR

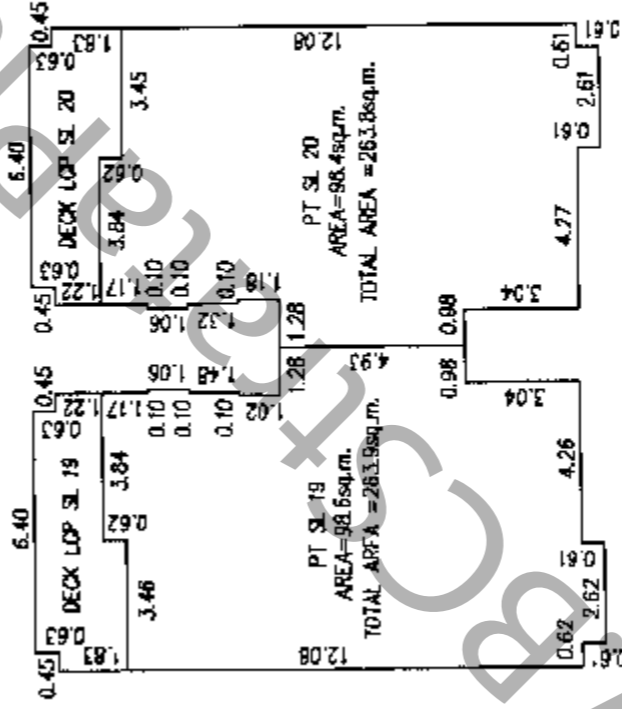

### MAIN FLOOR

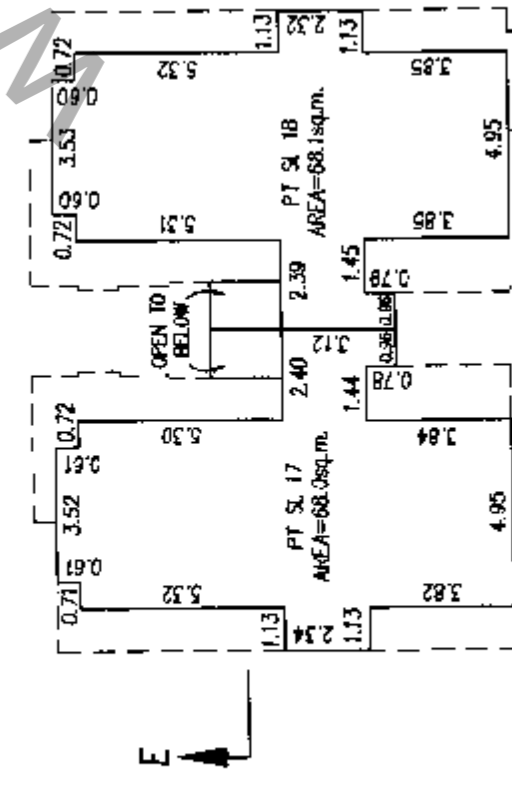

### MAIN FLOOR

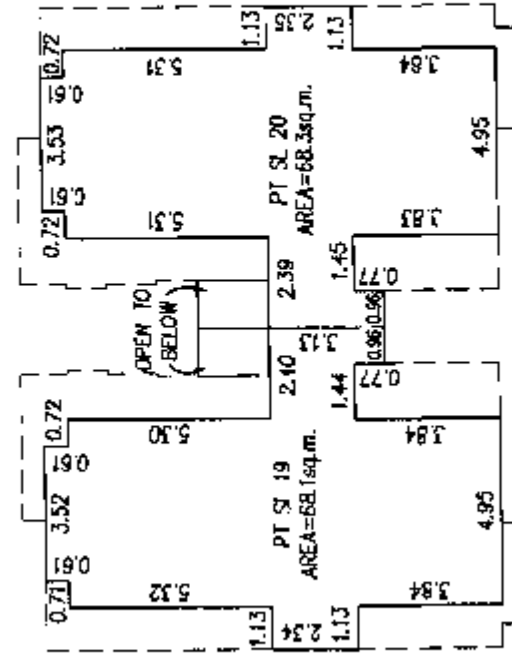

### UPPER FLOOR

### UPPER FLOOR

G.A.R.

# FLOOR PLANS

# STRATA PLAN LMS 3841

SCALE 1:200



ALL DISTANCES IN METRES

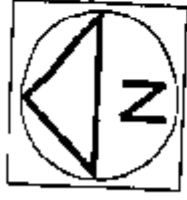

## PHASE 1

### BLOCK 15

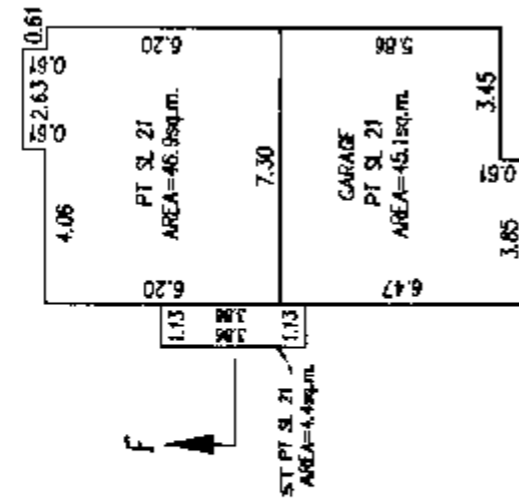

### BLOCK 16

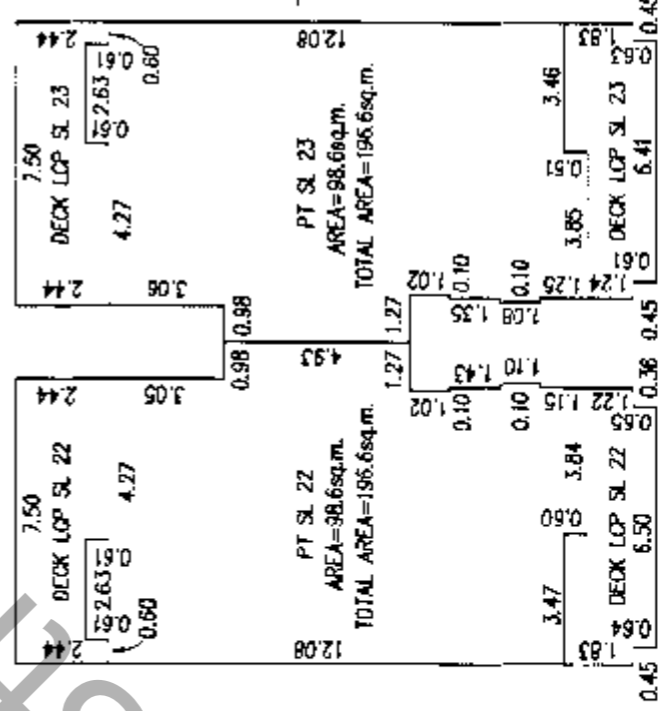
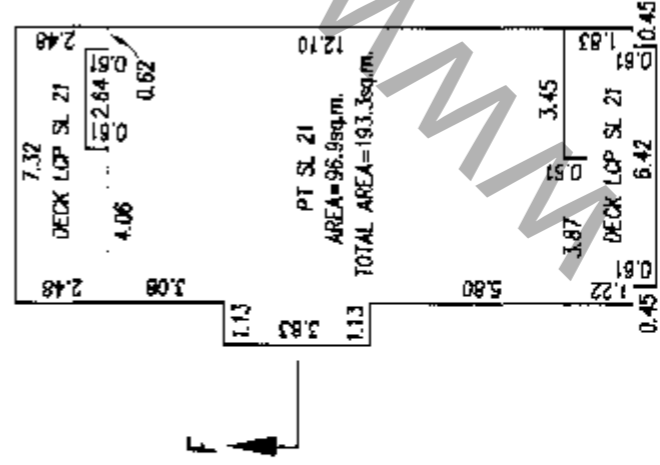
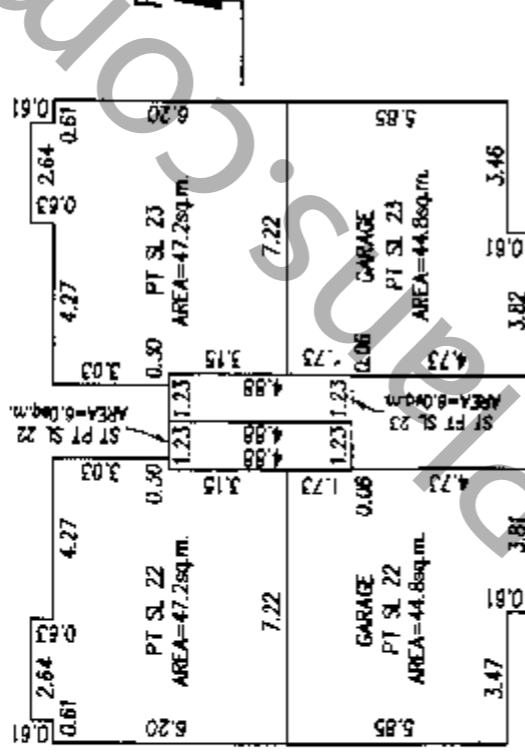

# G.A.R.

# FLOOR PLANS

## STRATA PLAN LMS 3841

### PHASE 1

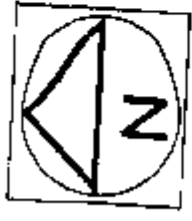

BLOCK 21

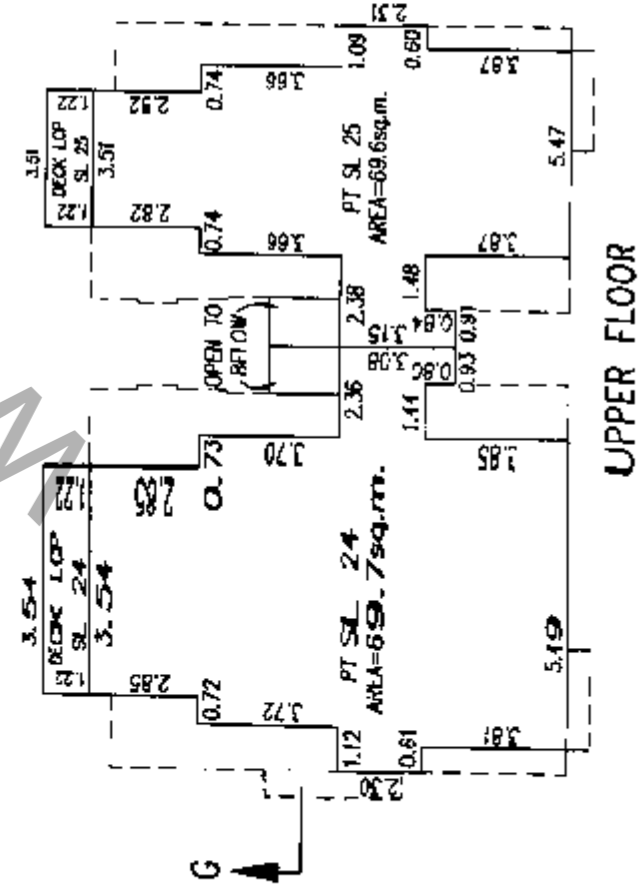
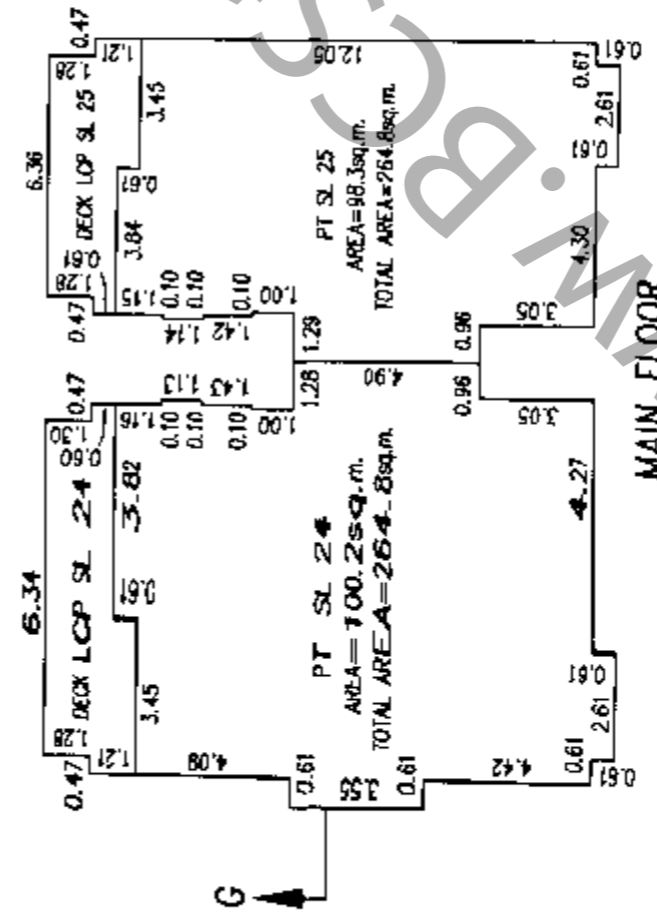
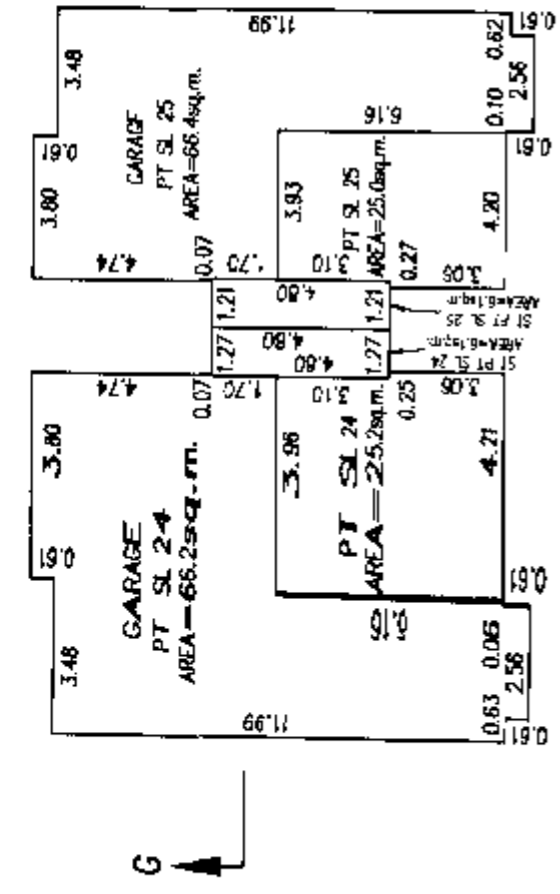

BLOCK 22

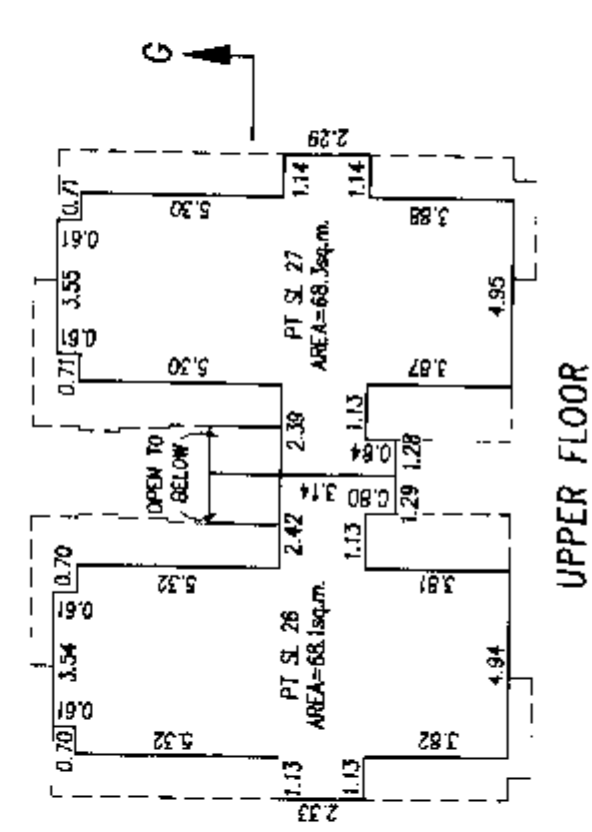
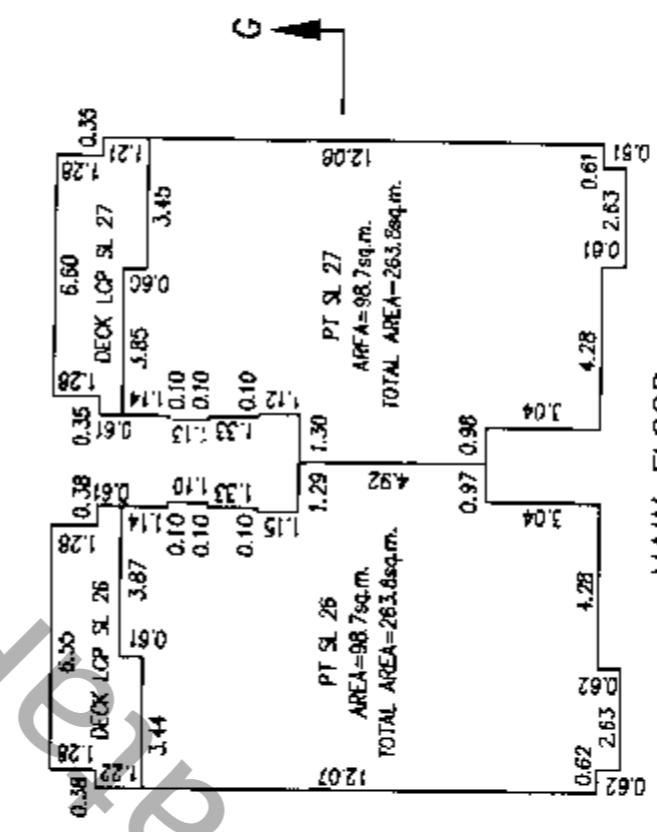
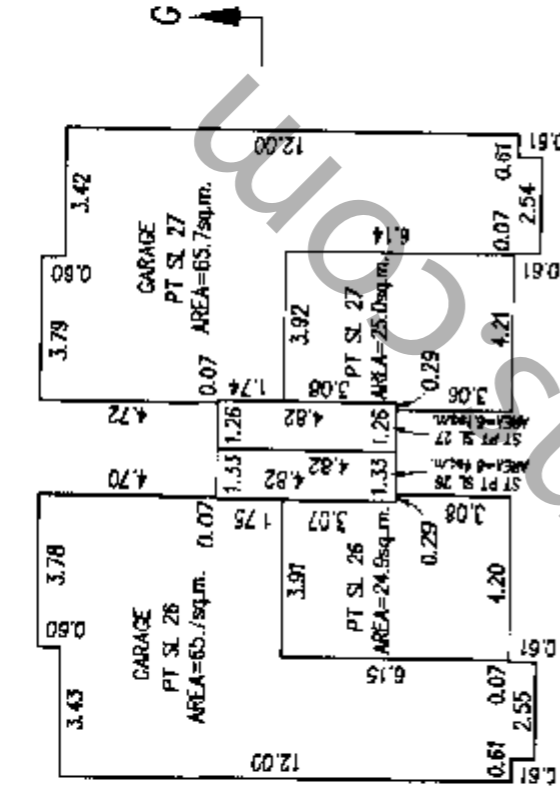

G.A.R.

DATED THIS 4th DAY OF FEB 1999.

B.G.L.S.

# STRATA PLAN LMS 3841 PHASE 1

## BLOCK 31

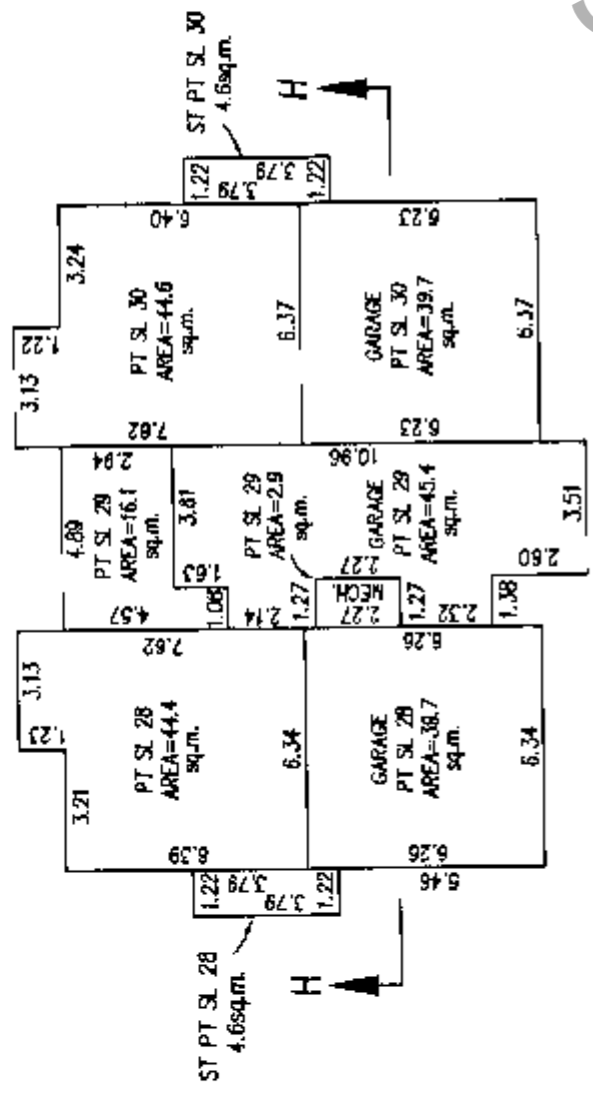
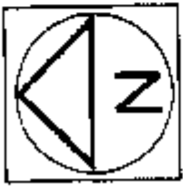

### GROUND FLOOR

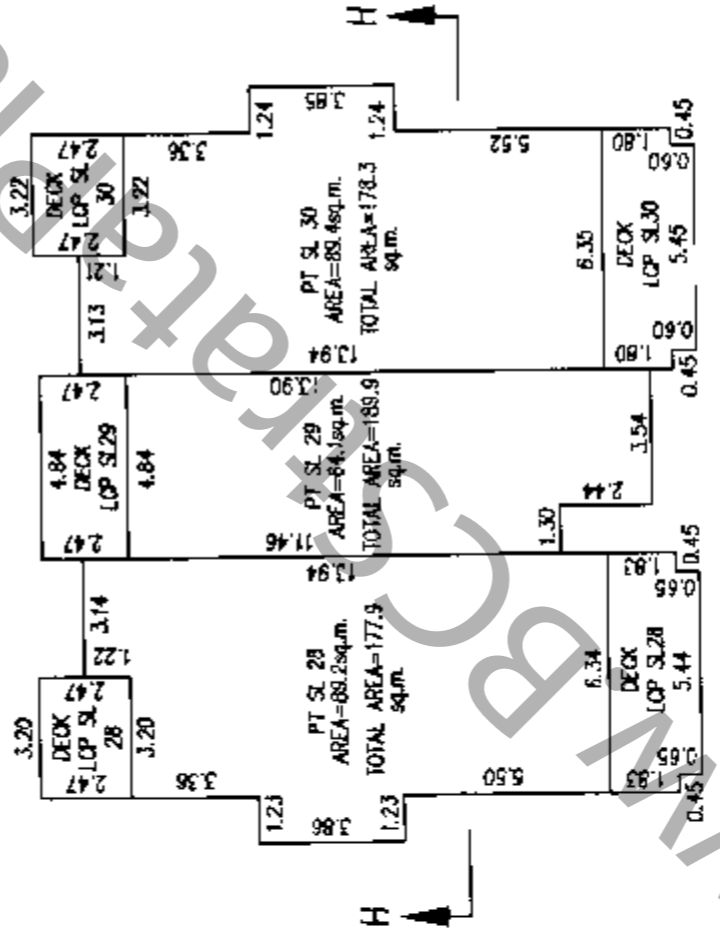

### MAIN FLOOR

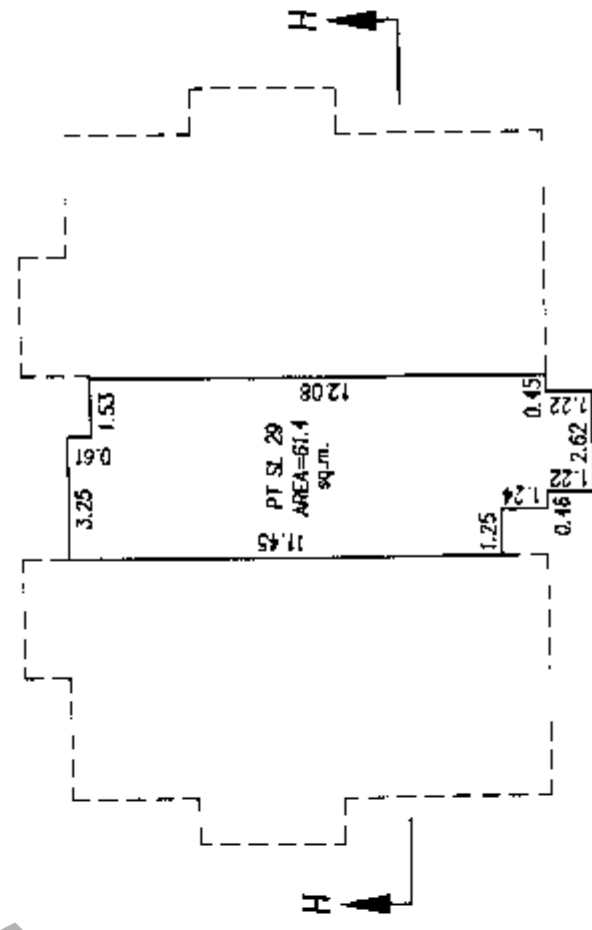

### UPPER FLOOR

# FLOOR PLANS

# STRATA PLAN LMS 3841

SCALE 1:200



ALL DISTANCES IN METRES

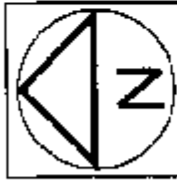

# PHASE 1

## BLOCK 30

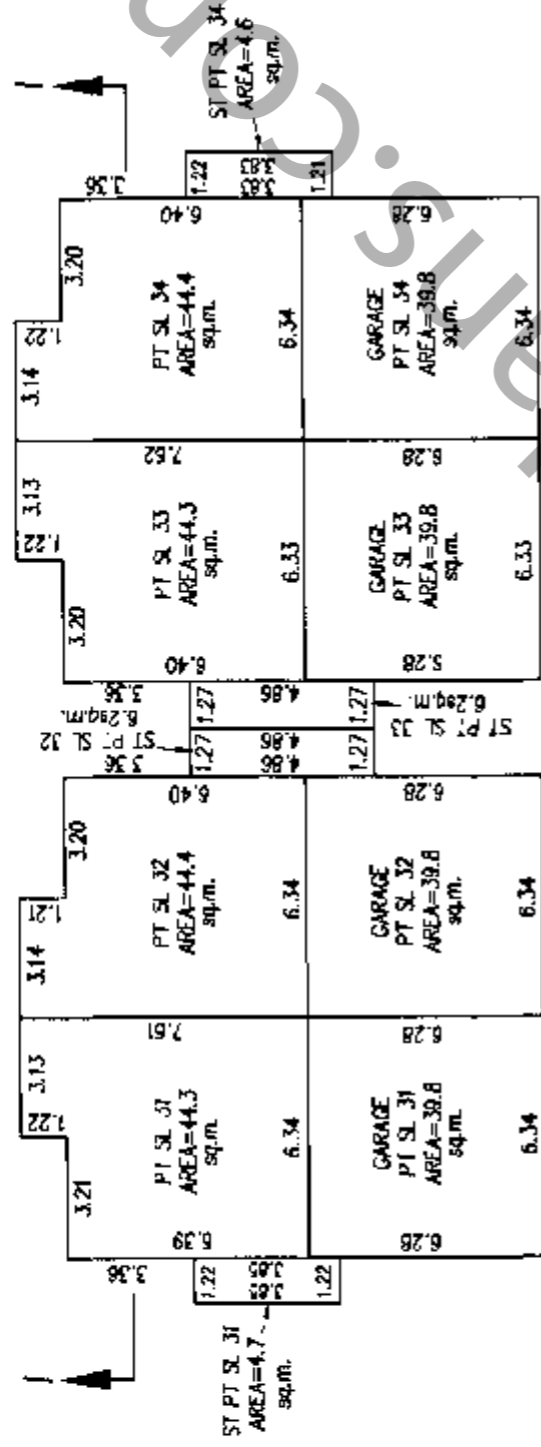

## GROUND FLOOR

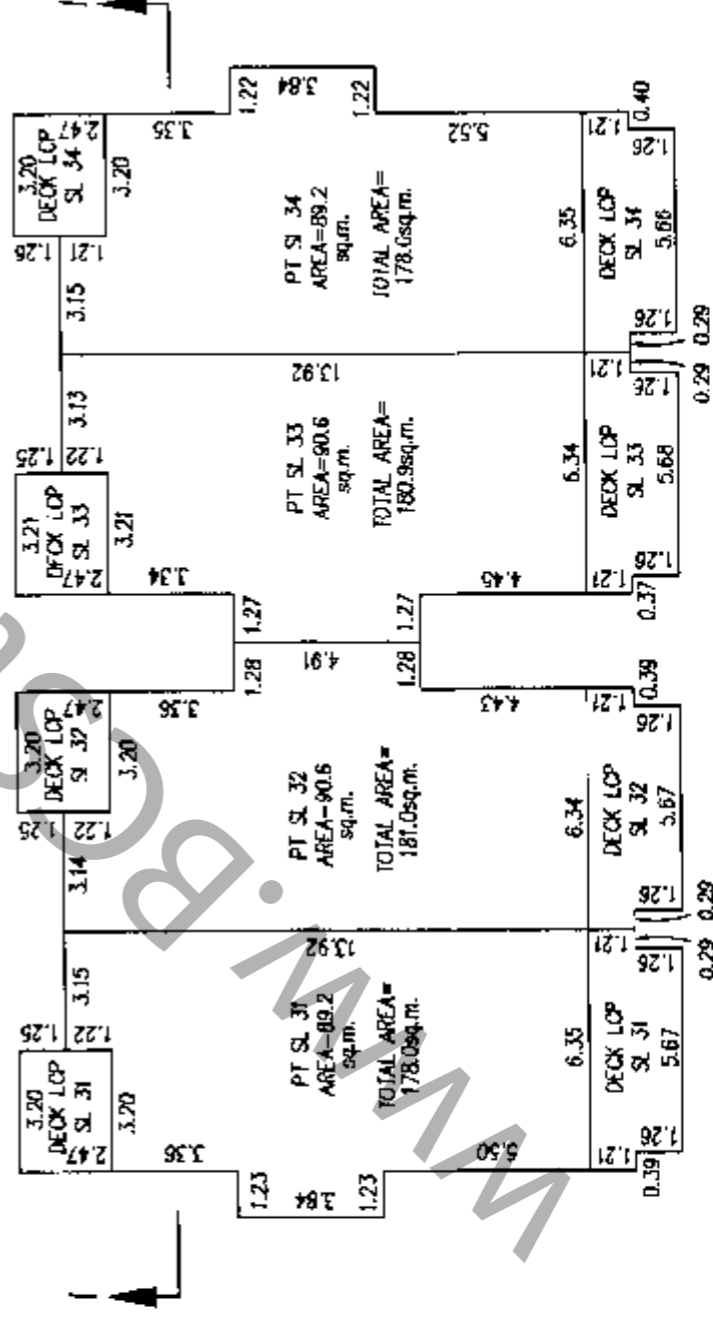

## MAIN FLOOR

G.A.R.

B.C.I.S.

DATED THIS 4<sup>th</sup> DAY OF FEB. 1999

# FLOOR PLANS

## STRATA PLAN LMS 3841

### PHASE 1

SCALE 1:200  
0 5 10 15  
ALL DISTANCES IN METRES

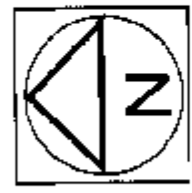

### BLOCK 29

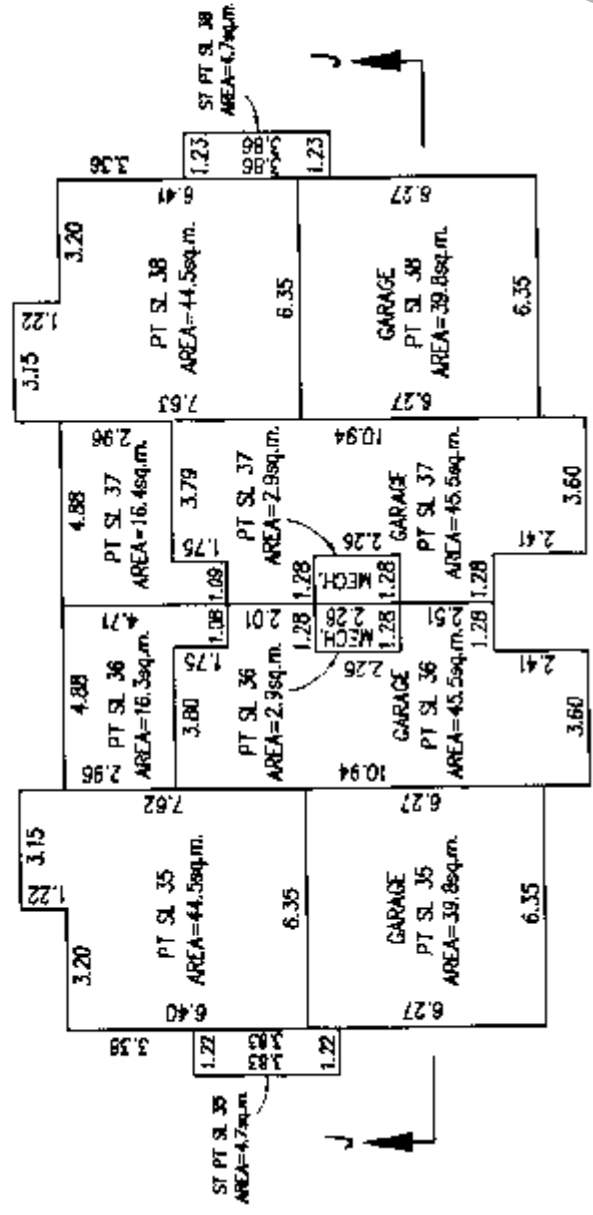

### GROUND FLOOR

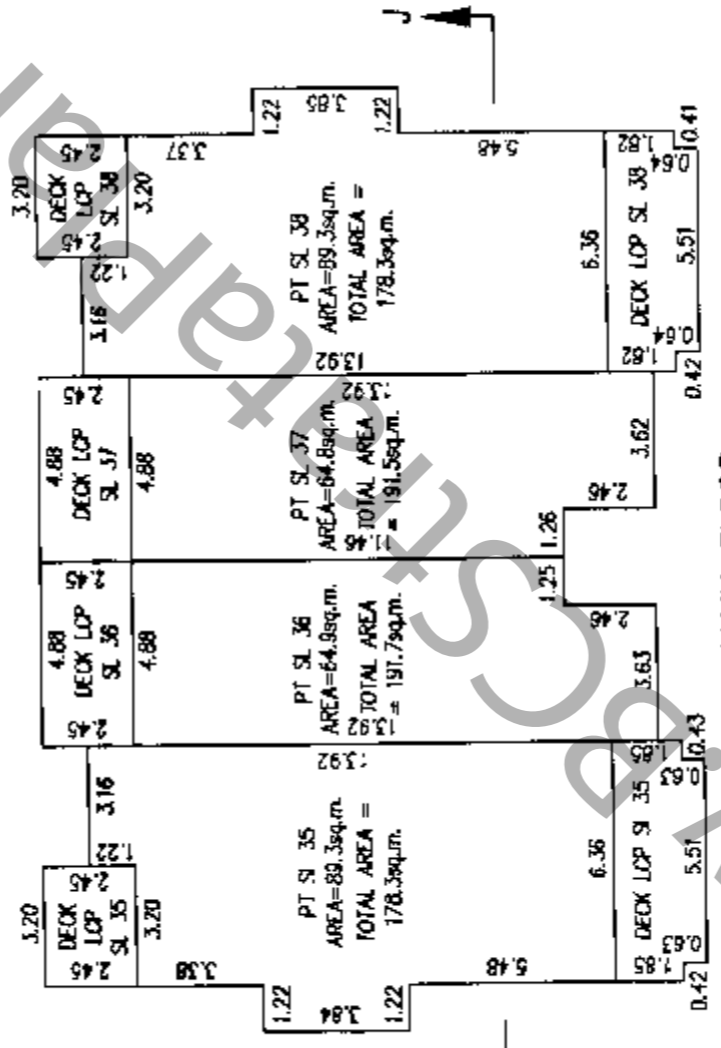

### MAIN FLOOR

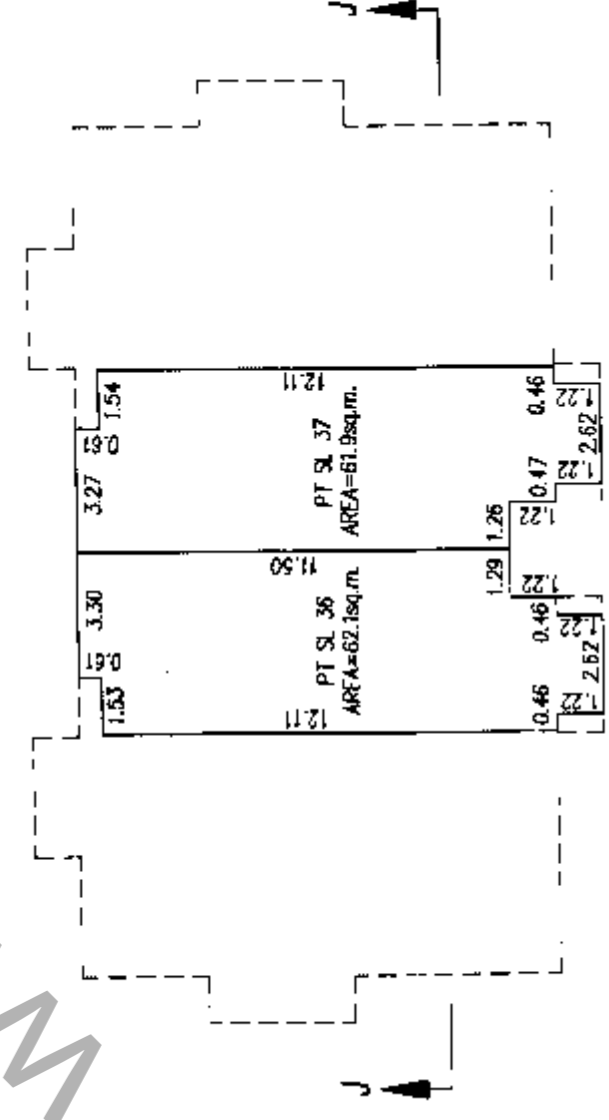

### UPPER FLOOR

### G.A.R.

14779A15 SHEET 15 OF 19 SHEETS

STRATA PLAN LMS 3841

PHASE 1

SECTIONS

SCALE 1:200

0 5 10 15

ALL DISTANCES IN METRES

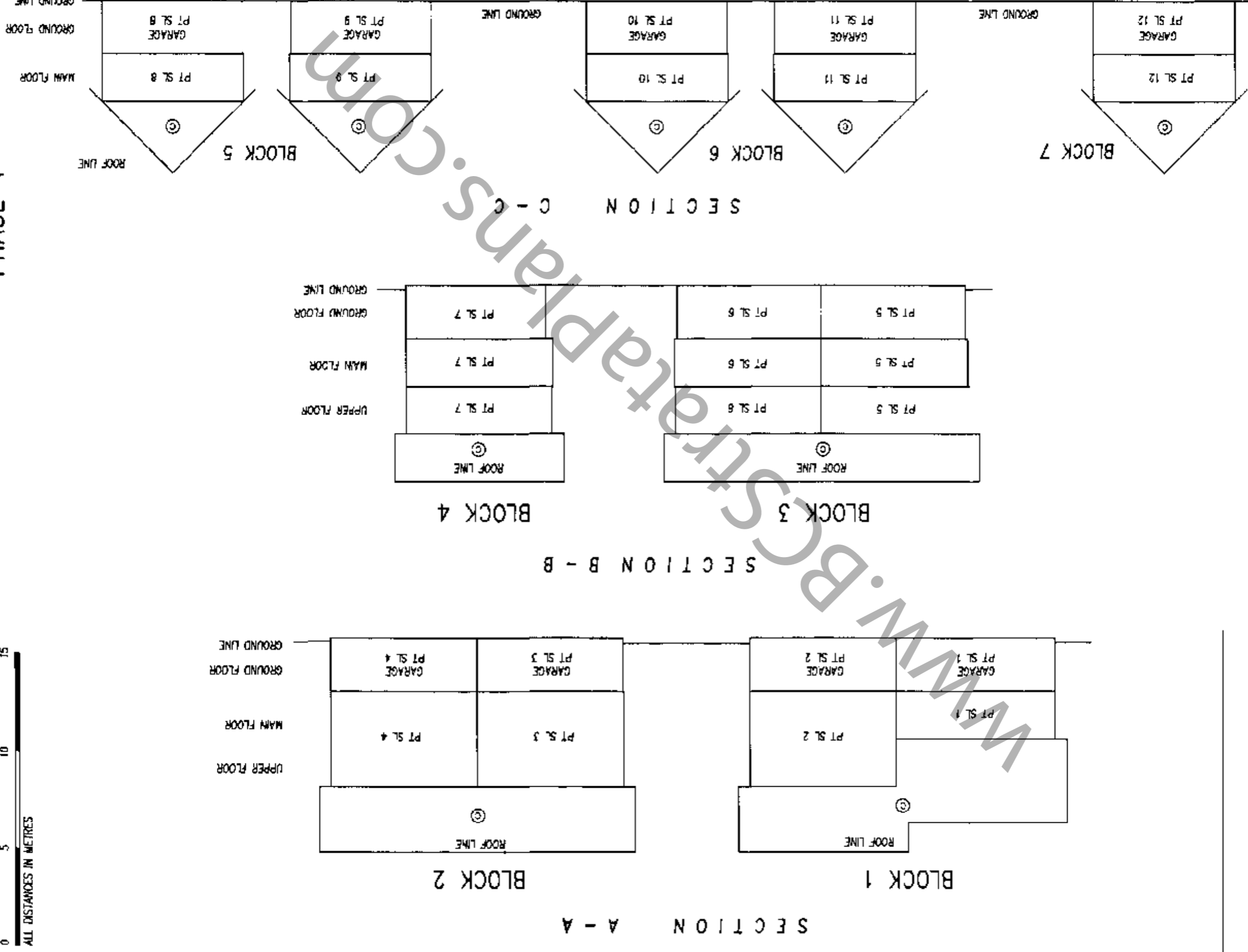

G.A.R.

B.C.L.S.

DATED THIS 4<sup>th</sup> DAY OF FEB. 1999

# SECTIONS

# STRATA PLAN LMS 3841

## PHASE 1

SCALE 1:200

0 5 10 15

ALL DISTANCES IN METRES

### SECTION D - D

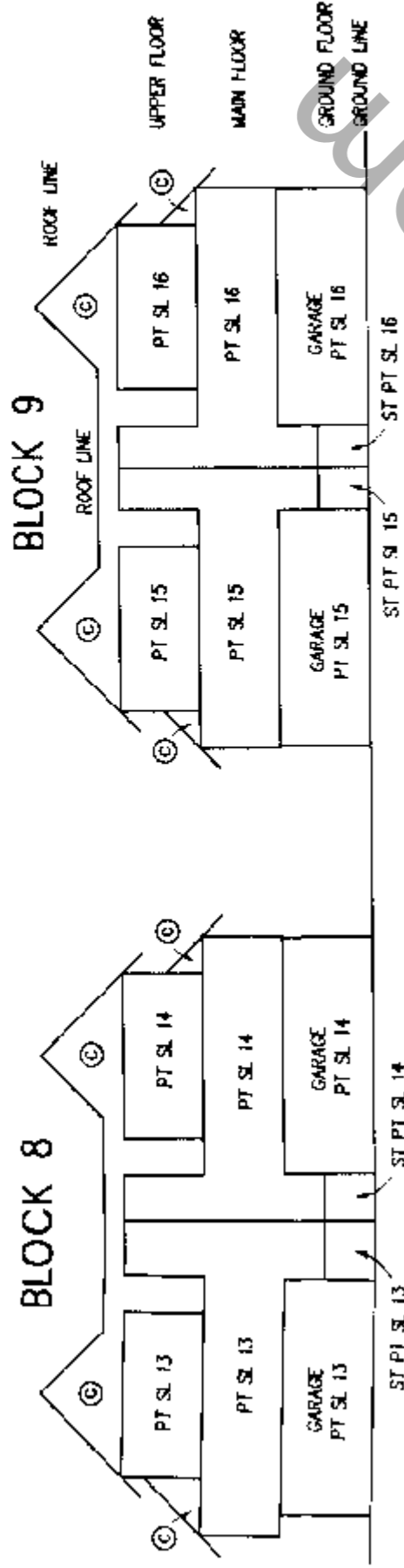

### SECTION E - E

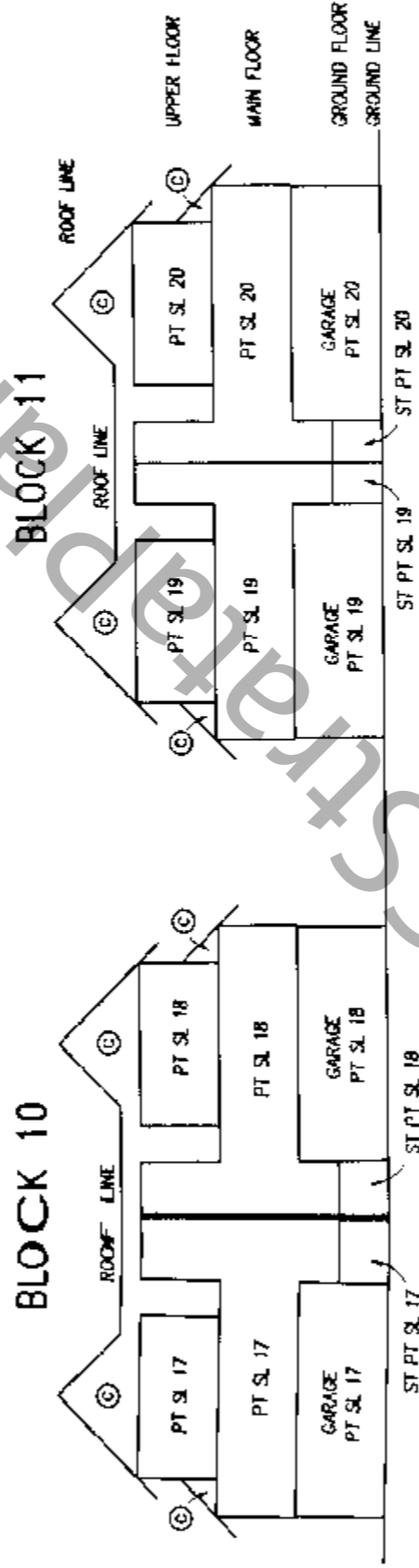

### SECTION F - F

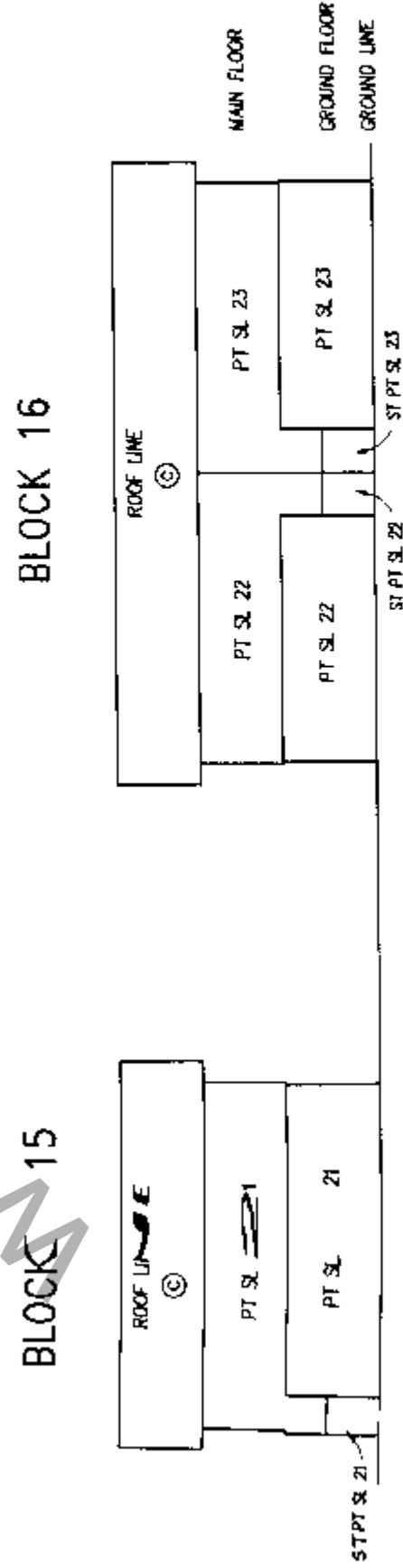

G.A.R.  
 DATED THIS 4th DAY OF FEB. 1999  
 B.C.L.S.



# SECTIONS

# STRATA PLAN LMS 3841

SCALE 1: 200

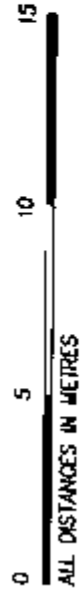

## PHASE 1

### SECTION G - G

#### BLOCK 21

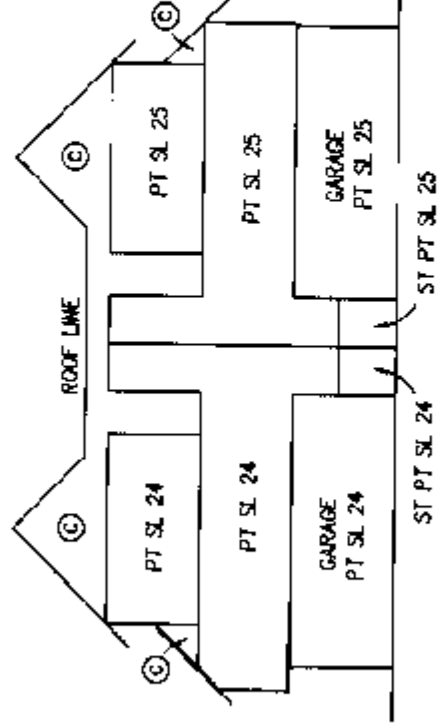

#### BLOCK 22

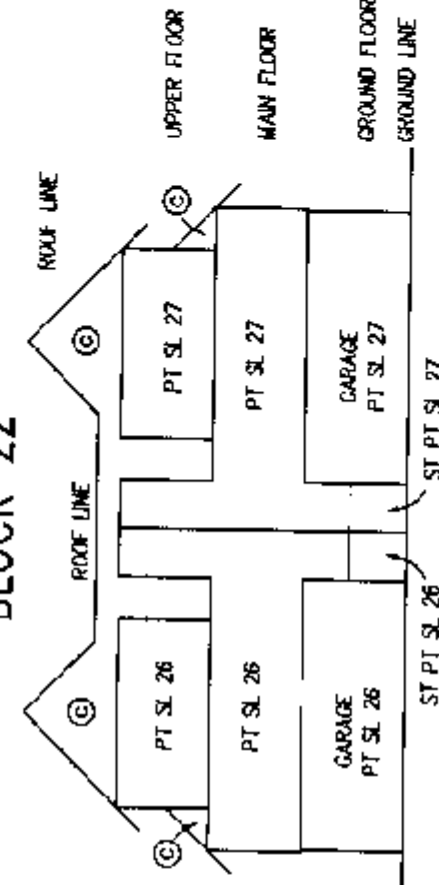

### SECTION H - H

#### BLOCK 31

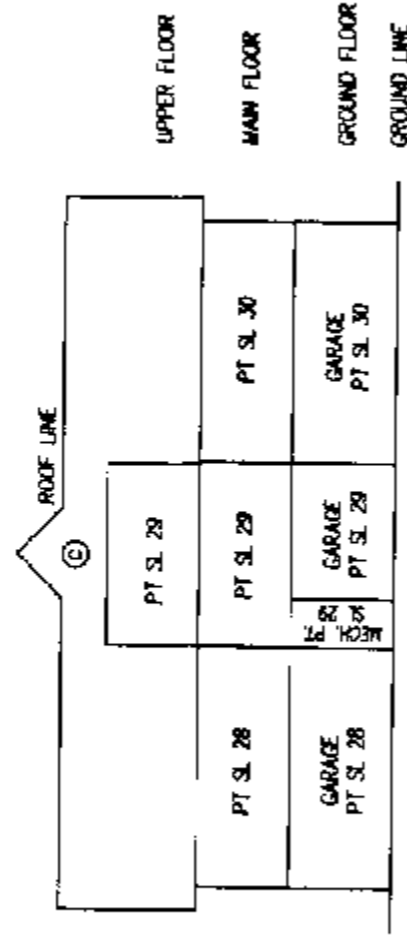

### SECTION I - I

#### BLOCK 30

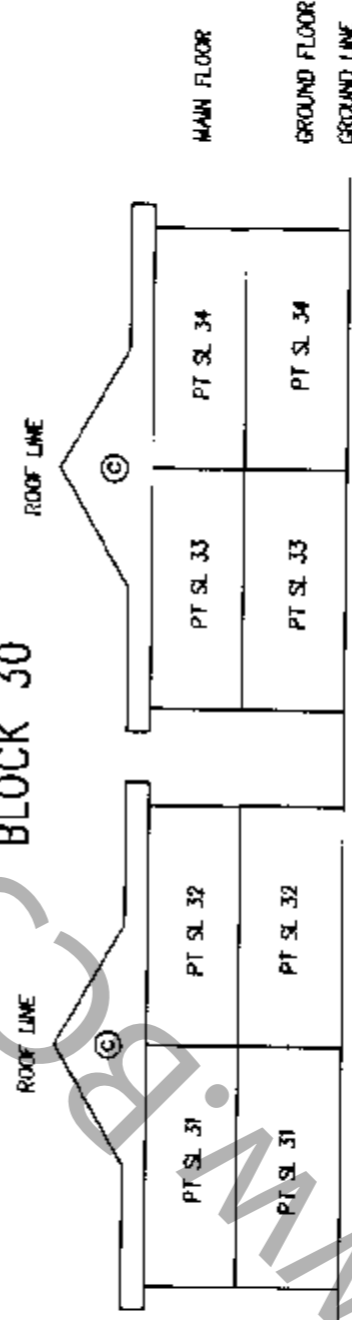

### SECTION J - J

#### BLOCK 29

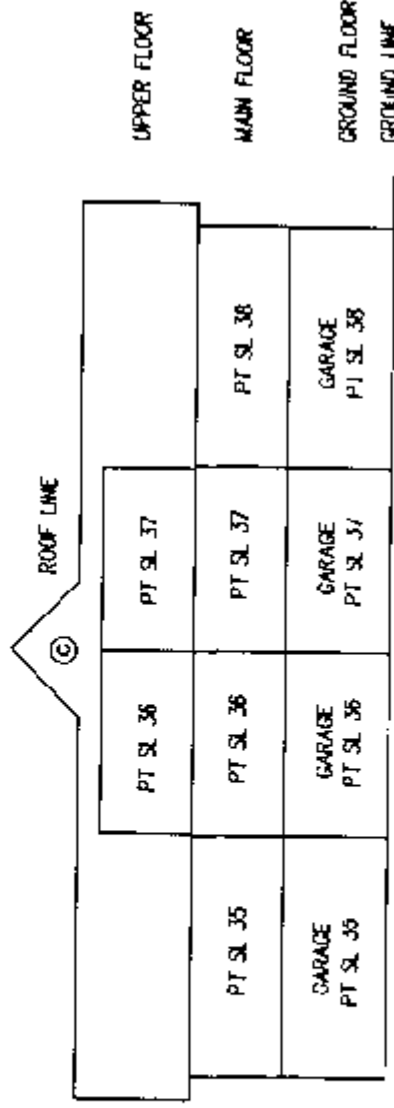

G.A.R.

DATED THIS 4<sup>th</sup> DAY OF FEB.

B.C.L.S.

1999

STRATA PLAN LMS 3841

RECORD OF BY LAWS AND ORDERS ETC.

FILING		DOCUMENT	
NUMBER	DATE	DATE	NATURE OF PARTICULARS
			<del>Bylaw Sheet Closed</del>
			Search ACCESS of BC OnLine for Current Information. BC Reg. 76/95

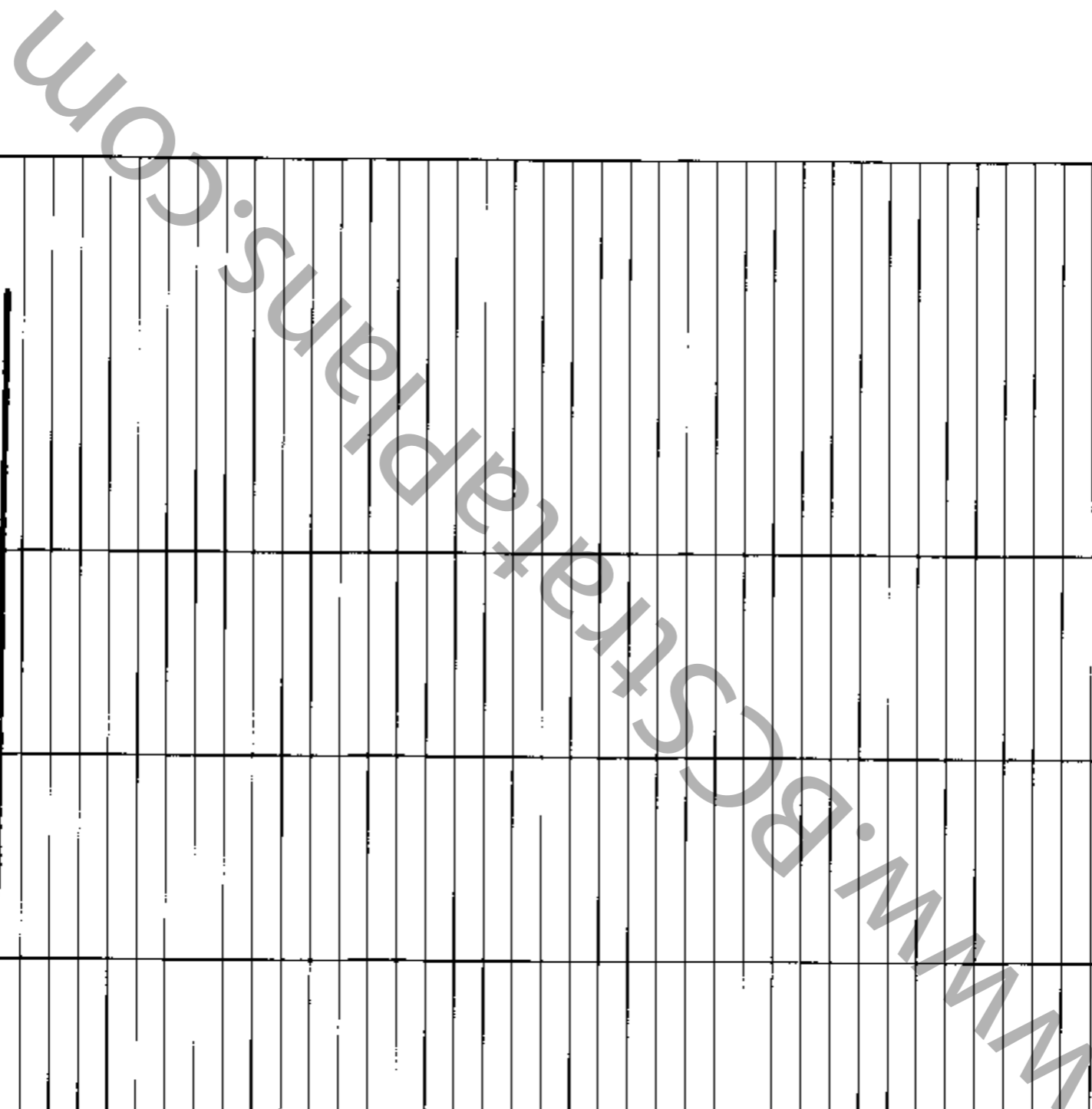

G.A.R.  
 B.C.L.S.  
 DATED THIS 4<sup>th</sup> DAY OF FEB. 1999



PHASED STRATA PLAN OF LOT A EXCEPT FIRSTLY: PHASE ONE  
 STRATA PLAN LMS3841, SECTION 23, TOWNSHIP 1,  
 N.W.D., PLAN LMP37657

STRATA PLAN LMS3841  
 PHASE 2

SCALE-1:1000

ALL DISTANCES ARE IN METRES

CITY OF SURREY  
 CIVIC ADDRESS  
 2588 152nd STREET



INTEGRATED SURVEY AREA  
 No.1 (SURREY) NA063 (CSRS)  
 B.C.G.S. 92C 006

DEPOSITED AND REGISTERED IN THE LAND TITLE OFFICE  
 AT NEW WESTMINSTER, B.C., February 13, 2002

*J. Small*  
 Deputy REGISTRAR  
 THIS PLAN LIES WITHIN THE GREATER VANCOUVER REGIONAL DISTRICT  
 BT 49362

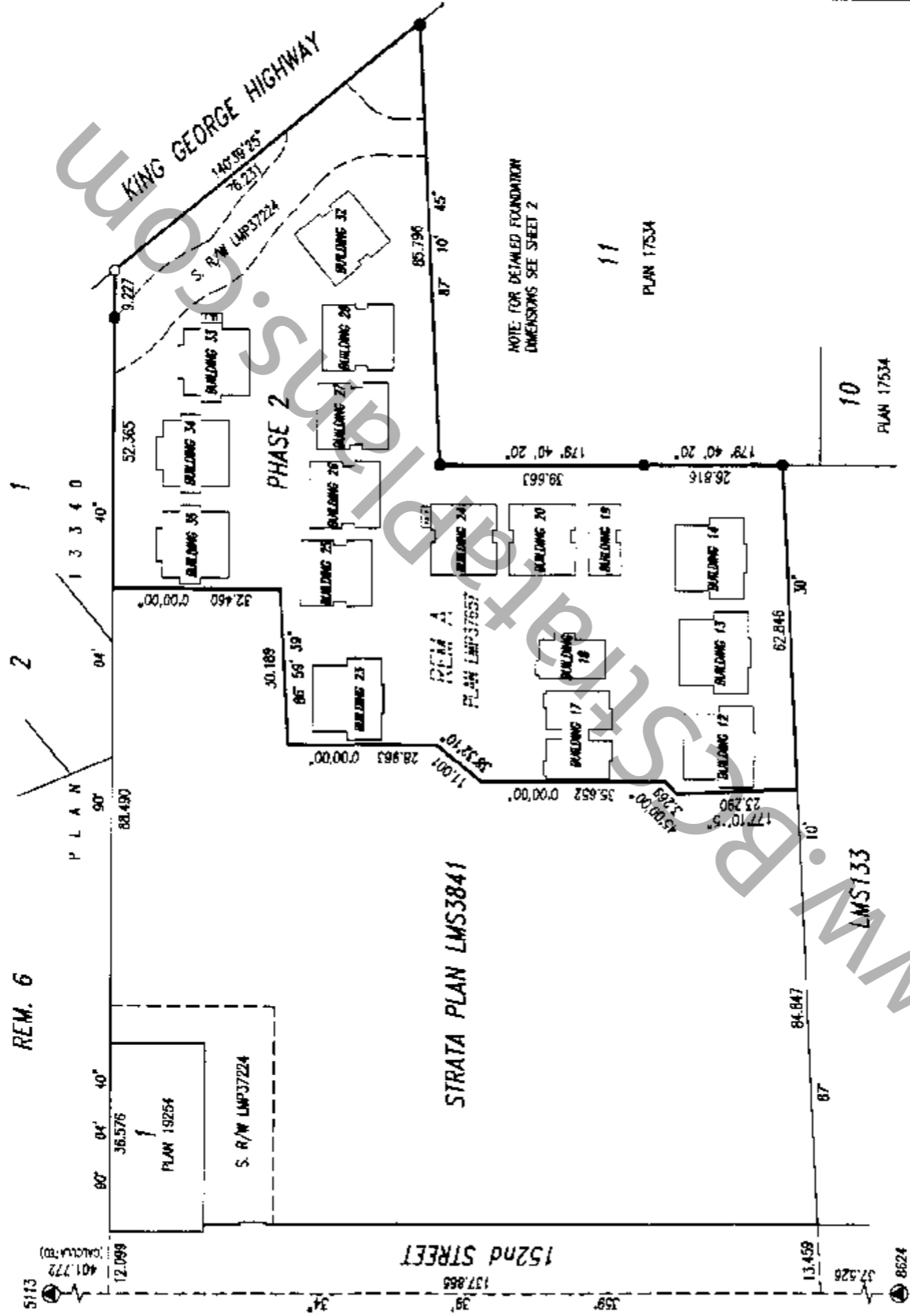

NOTE: FOR DETAILED FOUNDATION DIMENSIONS SEE SHEET 2

LEGEND

LCP	INDICATES	LIMITED COMMON PROPERTY
sq.m.		SQUARE METRES
SL		STRATA LOT
PT		PART
ST		STORAGE
⊙		COMMON PROPERTY
○		OLD IRON POST FOUND
●		IRON POST SET
■		OLD LEAD PLUG FOUND
□		LEAD PLUG SET
⊕		OLD CONTROL MONUMENT FOUND

STRATA LOT ANGLES ARE 45° OR 90° UNLESS OTHERWISE NOTED.

THIS PLAN SHOWS GROUND LEVEL MEASURED DISTANCES. PRIOR TO COMPUTATION OF UTM COORDINATES, MULTIPLY BY THE COMBINED FACTOR 0.9995932.

GRID BEARINGS ARE DERIVED FROM OLD CONTROL MONUMENT 8624 AND 5113

THE ADDRESS FOR SERVICE OF DOCUMENTS ON THE STRATA CORPORATION IS: THE OWNER'S STRATA PLAN LMS 3841

c/o 11520 78th AVENUE  
 SURREY, B.C. V3W 8J5

I, G.A. ROMEOTHAMA, A BRITISH COLUMBIA LAND SURVEYOR, CERTIFY THAT THE BUILDINGS SHOWN ON THIS STRATA PLAN ARE WITHIN THE EXTERNAL BOUNDARIES OF THE LAND THAT IS THE SUBJECT OF THE STRATA PLAN.

DATE: JANUARY 10, 2002  
*G.A. Romeothama*  
 B. C. L. S.

STRATA PLAN LMS3841  
PHASE 2

BUILDING FOUNDATION DETAIL

SCALE - 1:500



ALL DISTANCES IN METRES

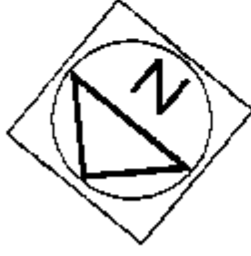

G.A.R.

DATED THIS 10th DAY OF JAN. 2002

B.C.L.S.

STRATA PLAN LMS3841

# SIGNATURES

# STRATA PLAN LMS3841 PHASE 2

### NEW DEVELOPMENT CERTIFICATE

I, G.A. Rombotham, A BRITISH COLUMBIA LAND SURVEYOR, HEREBY CERTIFY THAT THE BUILDINGS SHOWN IN THIS STRATA PLAN HAVE NOT, AS OF THE 10<sup>th</sup> DAY OF JANUARY, 2002, BEEN PREVIOUSLY OCCUPIED. DATED AT WHITE ROCK, BRITISH COLUMBIA, THIS 10<sup>th</sup> DAY OF JANUARY, 2002.

G.A. Rombotham  
B. C. L. S.

### STATUTORY DECLARATION

WE THE UNDERSIGNED DO SOLEMNLY DECLARE THAT:

- (1) WE THE UNDERSIGNED ARE THE OWNER DEVELOPER
- (2) THE STRATA PLAN IS ENTIRELY FOR RESIDENTIAL USE. WE MAKE THIS SOLEMN DECLARATION CONSCIOUSLY BELIEVING IT TO BE TRUE AND KNOWING THAT IT IS OF THE SAME FORCE AND EFFECT AS IF MADE UNDER OATH.

  
Moh Fani

DECLARED BEFORE ME THIS 11<sup>th</sup> DAY OF January, 2002

  
A COMMISSIONER FOR TAKING AFFIDAVITS WITHIN THE PROVINCE OF BRITISH COLUMBIA

Ed Wilson  
1600 - 925 W. Georgia St.  
Vancouver, B.C. V6C 3L2

ACCEPTED AS TO FORMS 1, 2 AND 3

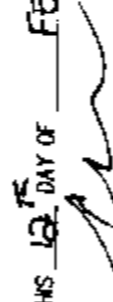
THIS 12<sup>th</sup> DAY OF FEBRUARY, 2002  
  
SUPERINTENDENT OF REAL ESTATE  
ELIZABETH WINESHANSIKA

APPROVED AS TO PHASE 2 OF A 2 PHASE STRATA PLAN

THIS 11<sup>th</sup> DAY OF February, 2002

  
APPROVING OFFICER FOR THE CITY OF SURREY  
NICHOLAS LAI

OWNER: SEMAHOO LAKE DEVELOPMENT LTD., (INC. No. 547188)

  
AUTHORIZED SIGNATORY

Moh Fani  
AUTHORIZED SIGNATORY

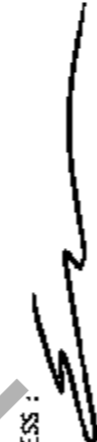
WITNESS:  

Ed Wilson  
ADDRESS AND OCCUPATION OF WITNESS:  
Lawyer  
1600 - 925 W. Georgia St.  
Vancouver B.C. V6C 3L2

THE CITY OF SURREY AS HOLDER OF COVENANTS BMT04310, BMT04311 AND BMT04312 HEREBY CONSENTS TO THE FILING OF THIS STRATA PLAN.

Dwight  
AUTHORIZED SIGNATORY  
Mayor: Doua McCallum  
AUTHORIZED SIGNATORY  
Acting City Clerk: MARGARET JONES

WITNESS:  
Susan Palmer Susan Palmer

ADDRESS AND OCCUPATION OF WITNESS:  
14245-56 Avenue  
Surrey, BC V3Y 3A2  
Administrative Coordinator

MORTGAGEE: THE BANK OF NOVA SCOTIA

  
AUTHORIZED SIGNATORY ARLENE BRENNAN

AUTHORIZED SIGNATORY ALEXANDRA PARLYAST

WITNESS:  
  
Rodney Rao

ADDRESS AND OCCUPATION OF WITNESS:  
Social Worker  
24th Floor 650 W. Georgia St.  
VAN. BC. V6B 4M7  
BANNER

G.A.R.

DATED THIS 10<sup>th</sup> DAY OF JAN., 2002

B.C.L.S.

# STRATA PLAN LMS3841

## PHASE 2

### CONDOMINIUM ACT

LOT NUMBER	SHEET NUMBER	FORM 1		FORM 2		FORM 3	
		SCHEDULE OF UNIT ENTITLEMENT	UNIT ENTITLEMENT	SCHEDULE OF INTEREST UPON DESTRUCTION	INTEREST UPON DESTRUCTION	SCHEDULE OF VOTING RIGHTS	NUMBER OF VOTES
39	5		1442		260		
40	5		1439		260		
41	6		1443		260		
42	6		1445		260		
43	6		1439		255		
44	6		1439		255		
45	7		1592		277		
46	7		1593		277		
47	8		1437		268		
48	8		1437		268		
49	8		1435		268		
50	8		1435		268		
51	9		1436		263		
52	9		1436		263		
53	9		1438		263		
54	9		1436		263		
55	10		1430		263		
56	10		1437		263		
57	11		1568		277		
58	11		1571		277		
59	11		1558		280		
60	12		1440		273		
61	12		1438		273		
62	13		1438		273		
63	13		1439		273		
64	13		1427		278		
65	14		1596		275		
66	14		1597		275		
67	15		1596		275		
68	15		1596		275		
69	15		1595		275		
70	15		1595		275		
		AGGREGATE PHASE 2	47654		8608		
		AGGREGATE PHASE 1	66909		11932		
		TOTAL AGGREGATE	114563		20540		

G.A.R.

# FLOOR PLANS

# STRATA PLAN LMS3841

SCALE 1:200



ALL DISTANCES IN METRES

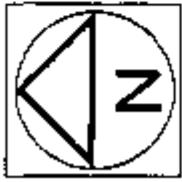

## BUILDING 35

### MAIN FLOOR

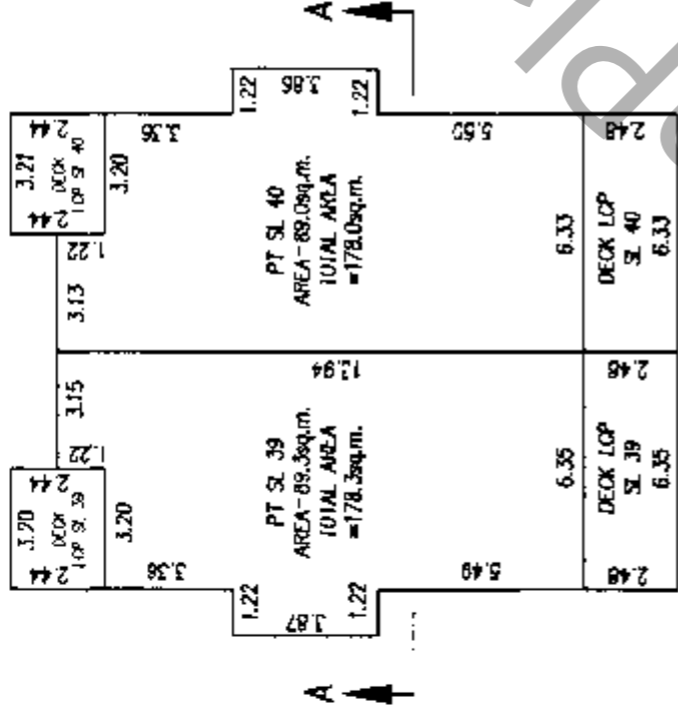

### GROUND FLOOR

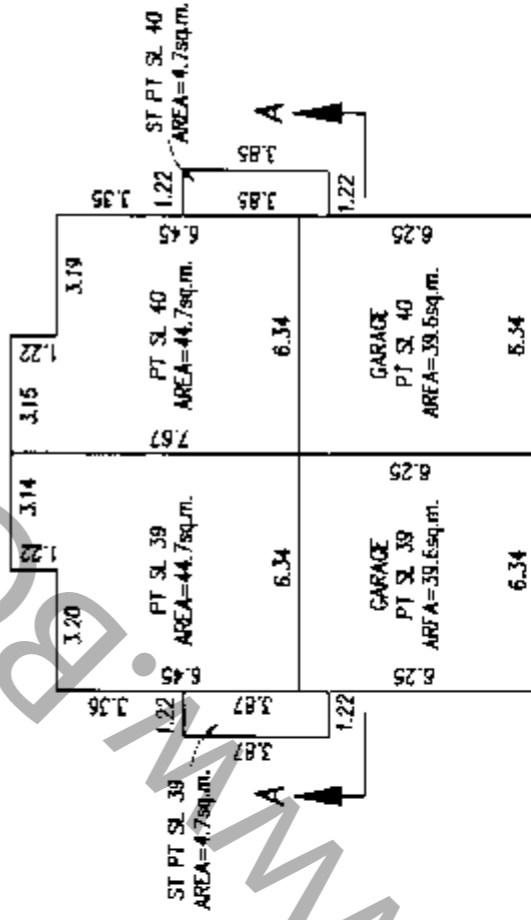

G.A.R.

DATED I/FMS 10<sup>th</sup> DAY OF JAN. 2002

B.C.L.S.



SCALE 1:200



ALL DISTANCES IN METRES

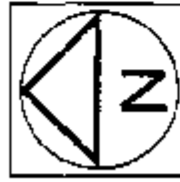

# FLOOR PLANS

# STRATA PLAN LMS3841

## PHASE 2

### BUILDING 34

#### MAIN FLOOR

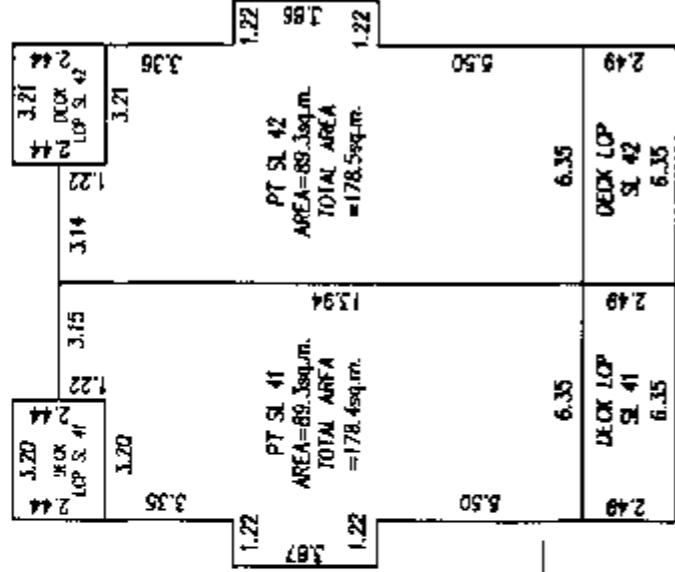

### BUILDING 33

#### MAIN FLOOR

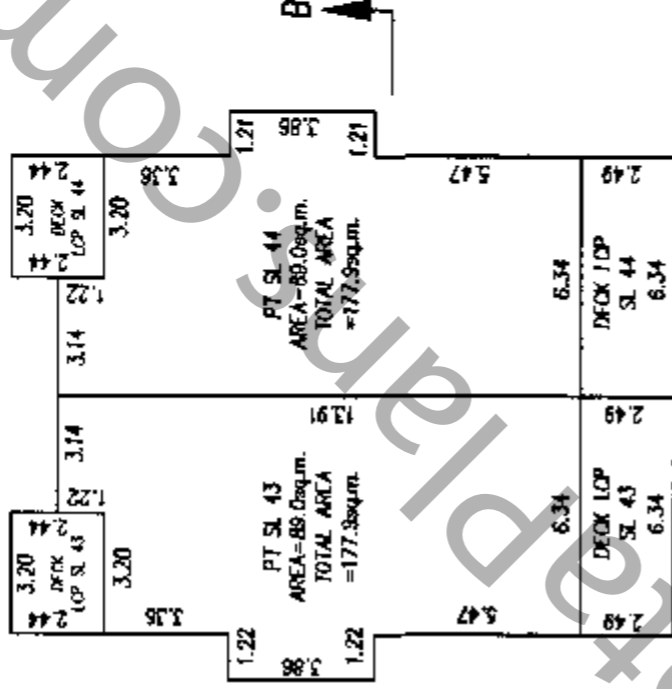

#### GROUND FLOOR

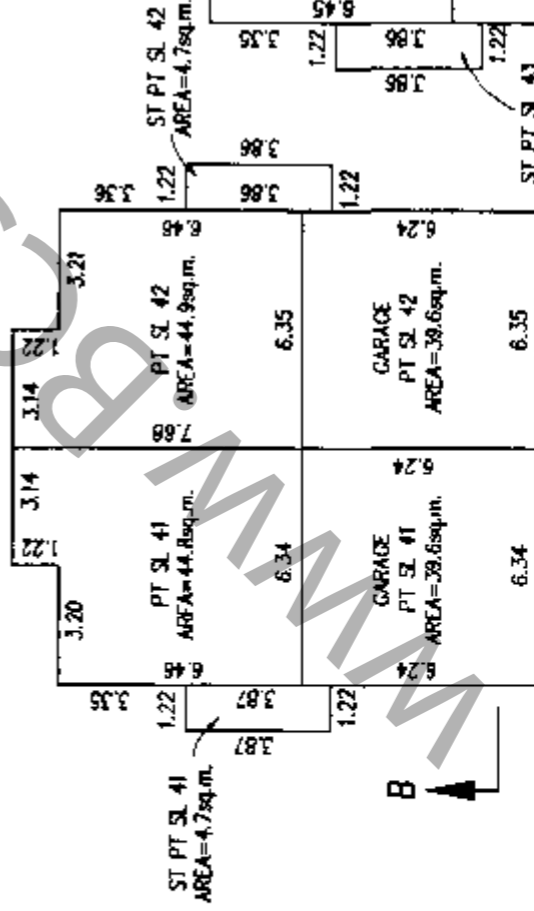

#### GROUND FLOOR

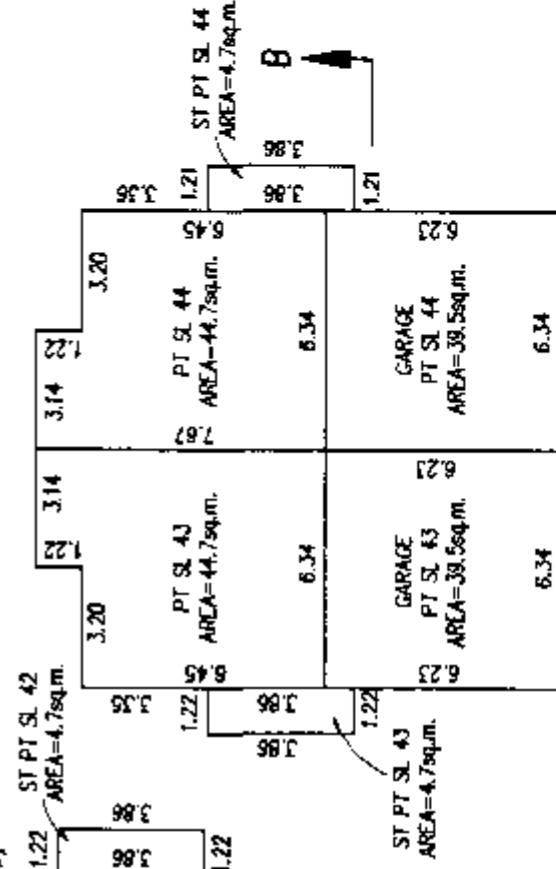

G.A.R.

B.C.L.S.

DATED THIS 10th DAY OF JAN. 2002

FLOOR PLANS

STRATA PLAN LMS3841

SCALE 1:200



ALL DISTANCES IN METRES

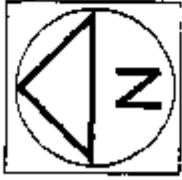

BUILDING 23  
MAIN FLOOR

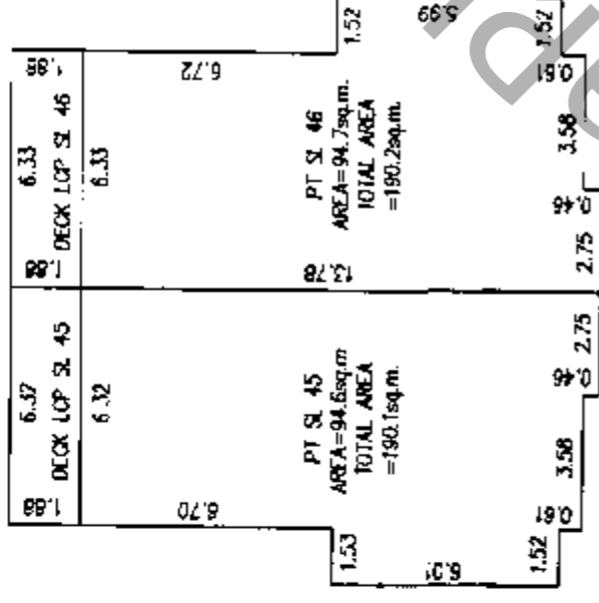

GROUND FLOOR

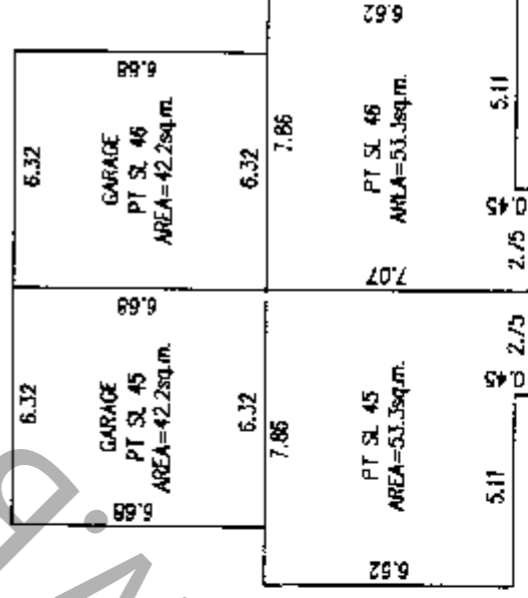

G.A.R.

DATED THIS 10th DAY OF JAN. 2002

B.C.L.S.

2002

FLOOR PLANS

STRATA PLAN LMS3841

PHASE 2

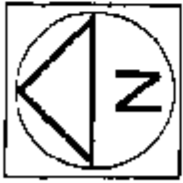
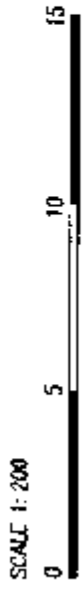

BUILDING 25 BUILDING 26

MAIN FLOOR

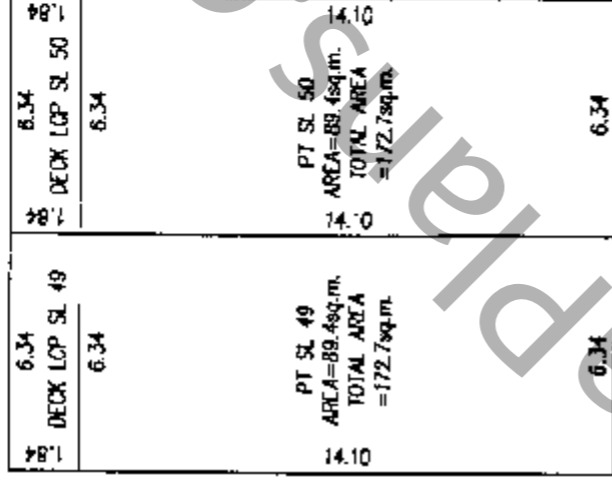
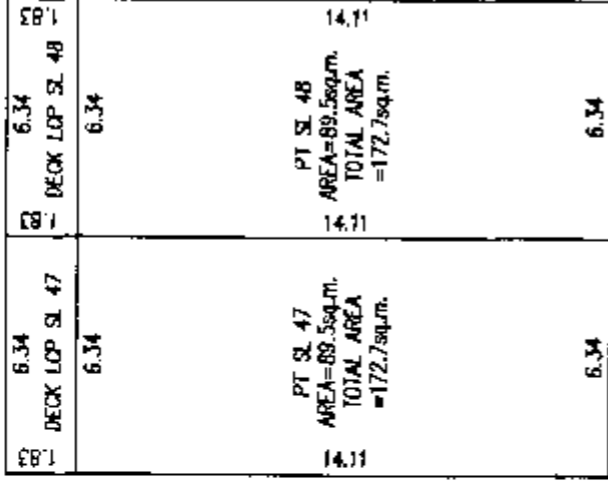

GROUND FLOOR

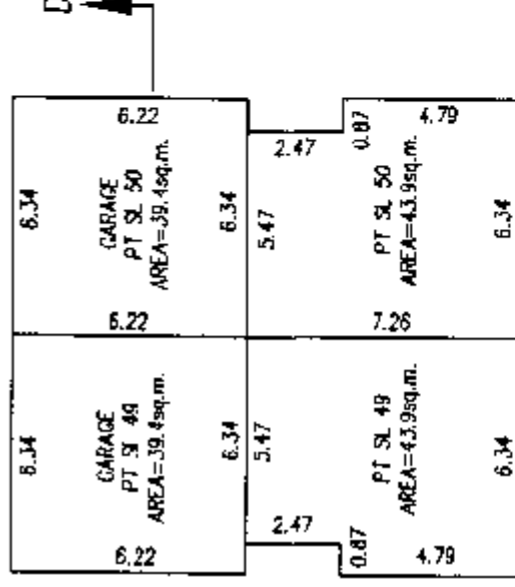
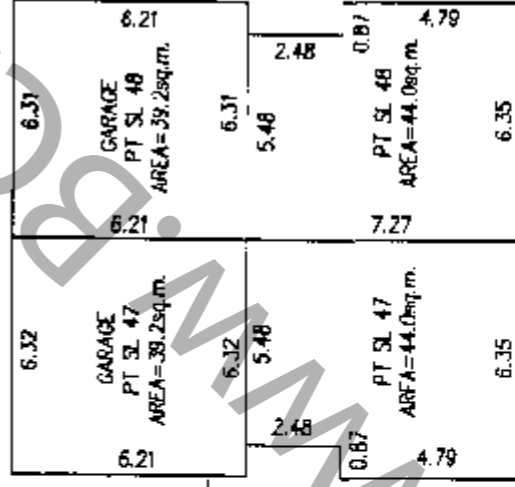

G.A.R.

DATED THIS 10<sup>th</sup> DAY OF JAN. 2002

B.C.L.S

# FLOOR PLANS

# STRATA PLAN LMS3841

SCALE 1:200

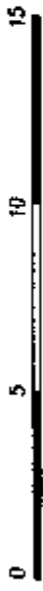

ALL DISTANCES IN METRES

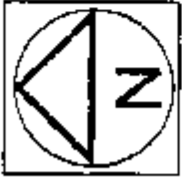

## PHASE 2

### BUILDING 27

### BUILDING 28

#### MAIN FLOOR

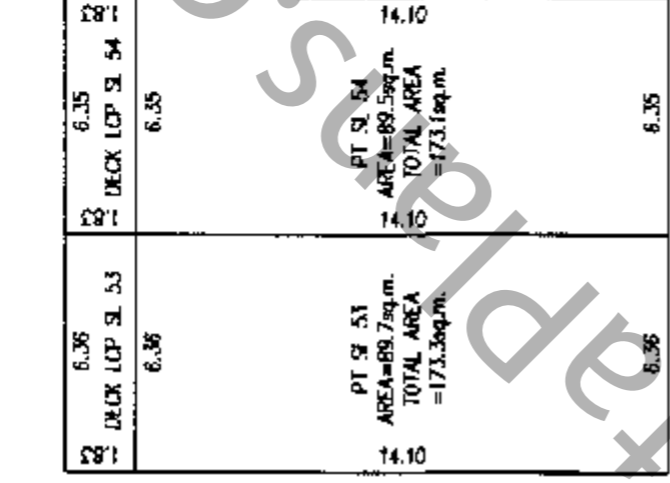
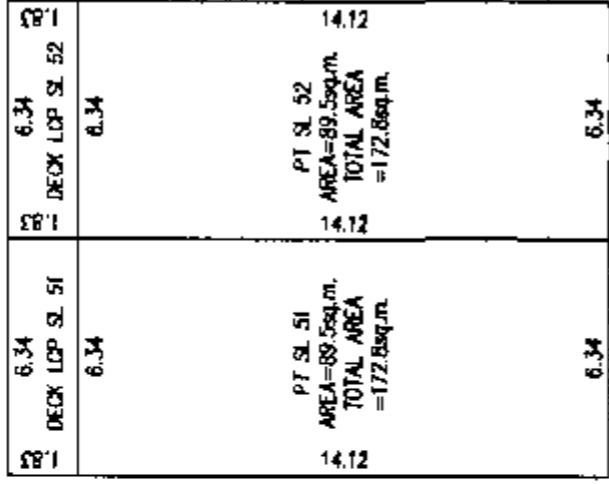

#### GROUND FLOOR

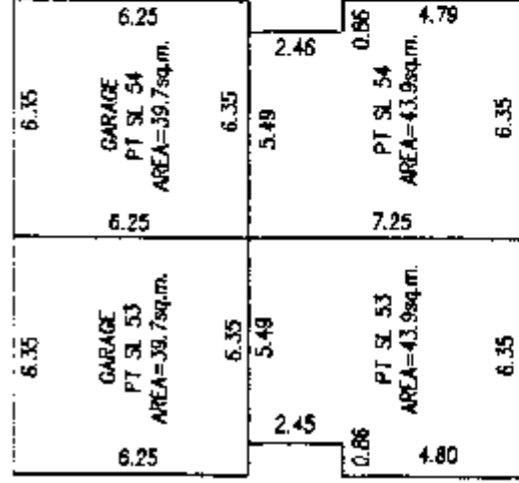
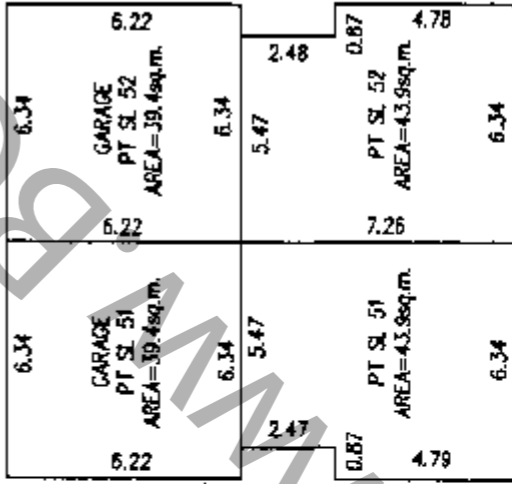

G.A.R.

B.C.L.S.

DATED THIS 10<sup>th</sup> DAY OF JAN 2002

# FLOOR PLANS STRATA PLAN LMS3841 PHASE 2

SCALE 1:200  
0 5 10 15  
ALL DISTANCES IN METRES

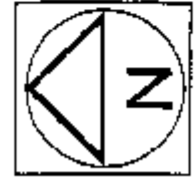

BUILDING 32

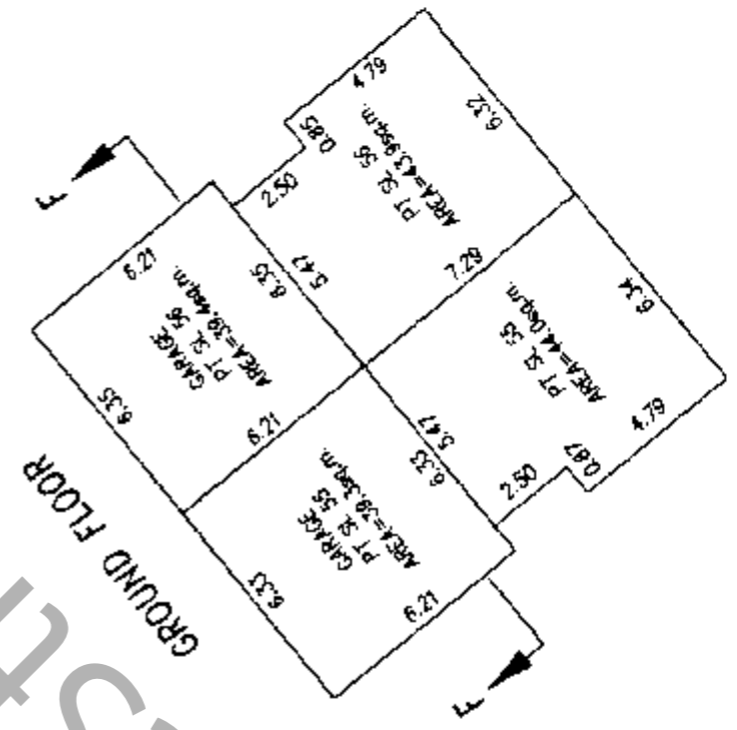
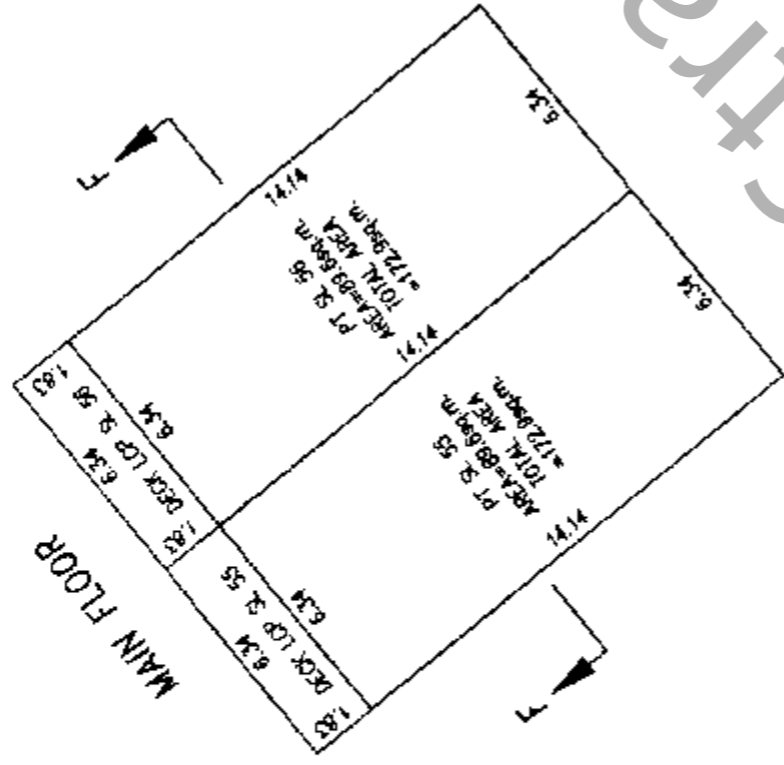

WWW.BCSstrataPlans.com

G.A.R.  
DATED THIS 10th DAY OF JAN. 2002  
B.C.L.S.

# FLOOR PLANS

## STRATA PLAN LMS3841 PHASE 2

SCALE 1:200

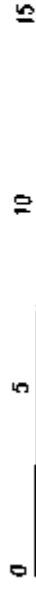

ALL DISTANCES IN METRES

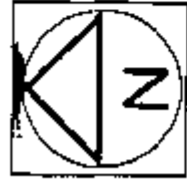

### BUILDING 17 MAIN FLOOR

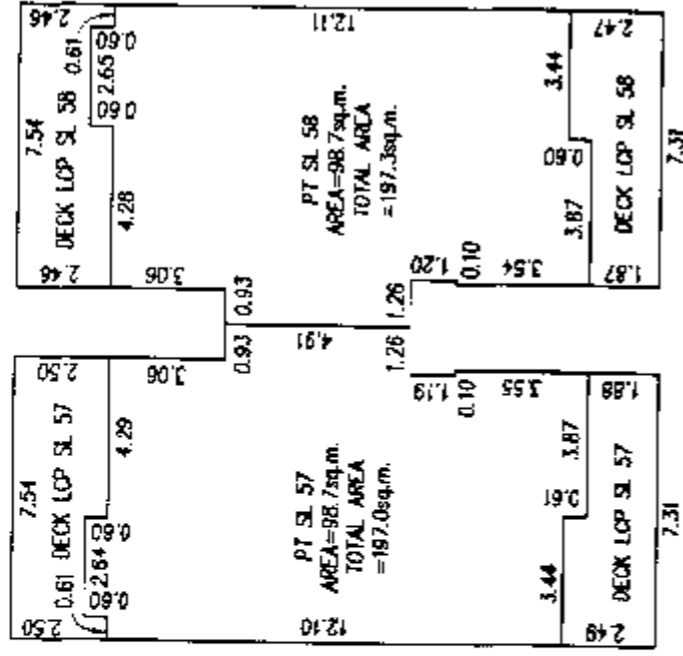

### BUILDING 18 MAIN FLOOR

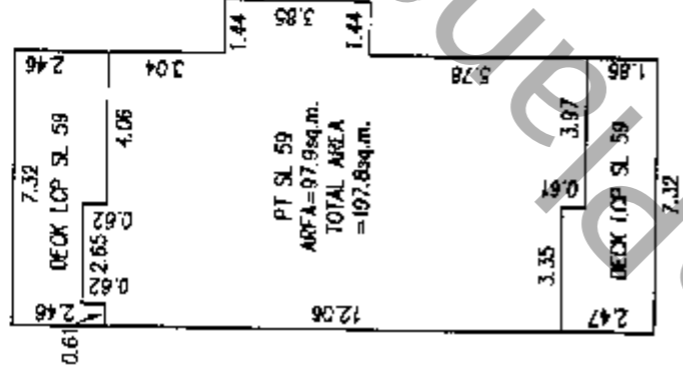

### GROUND FLOOR

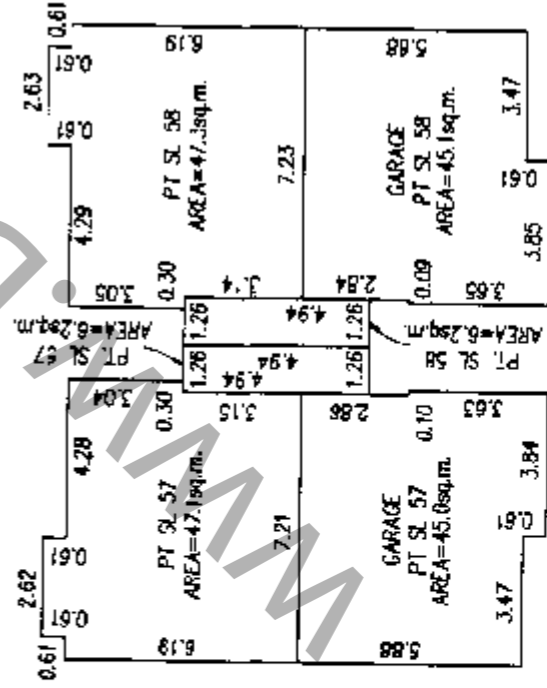

### GROUND FLOOR

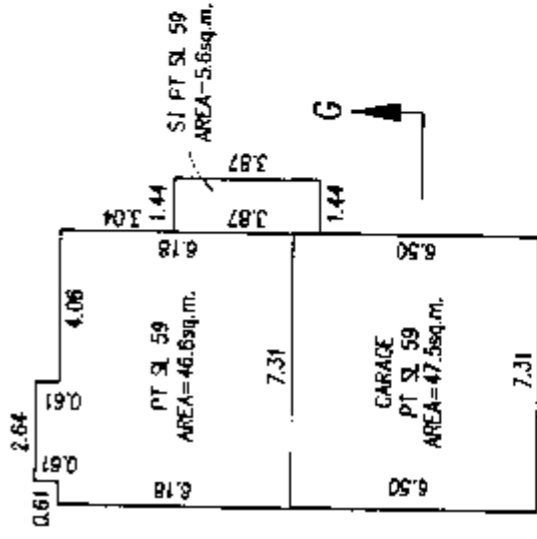

DATED THIS 10<sup>th</sup> DAY OF JAN. 2002

G.A.R. B.C.L.S.

# FLOOR PLANS

# STRATA PLAN LMS3841

## PHASE 2

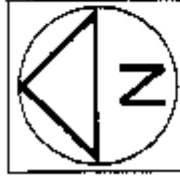
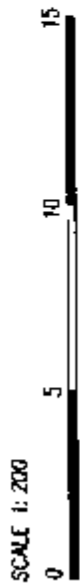

### BUILDING 24 MAIN FLOOR

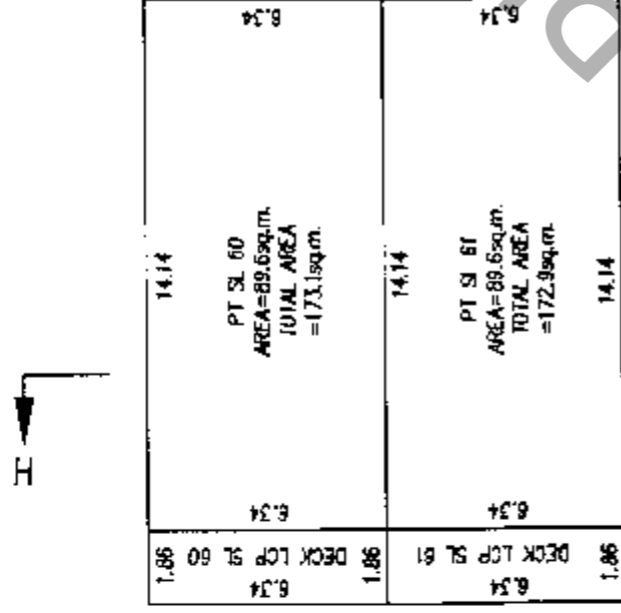

### GROUND FLOOR

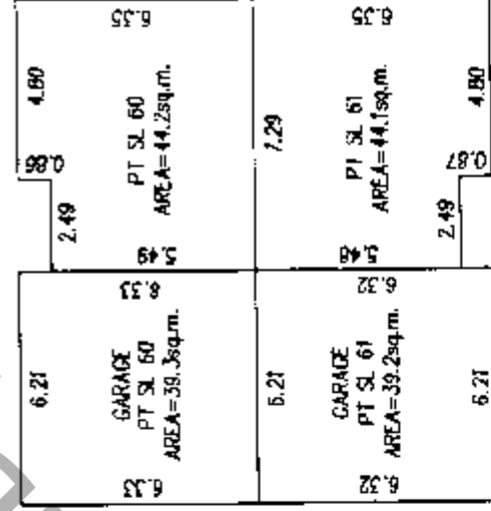

G.A.R.

DATED THIS 10<sup>th</sup> DAY OF JAN. 2002

B.C.L.S

# FLOOR PLANS

# STRATA PLAN LMS3841 PHASE 2

SCALE 1:200  
0 5 10 15  
ALL DISTANCES IN METRES

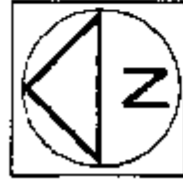

MAIN FLOOR

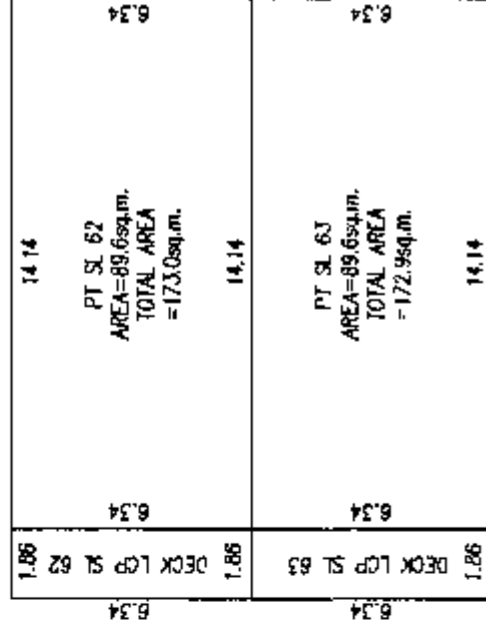

BUILDING 20

MAIN FLOOR

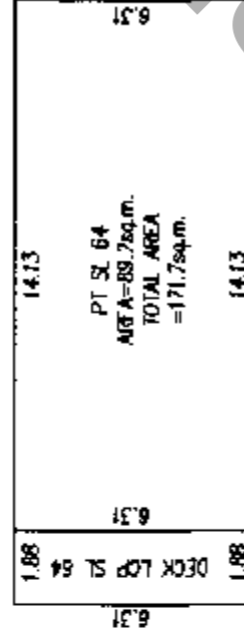

BUILDING 19

GROUND FLOOR

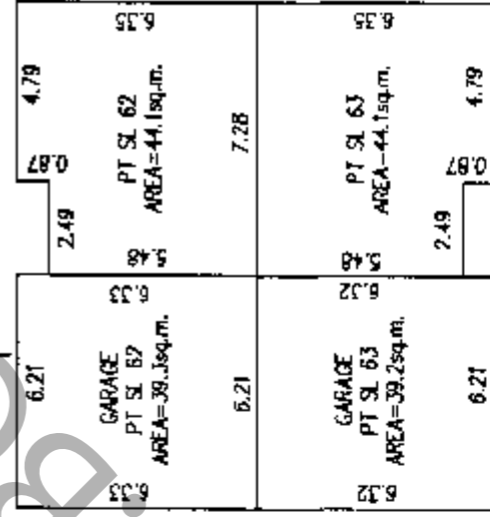

BUILDING 20

GROUND FLOOR

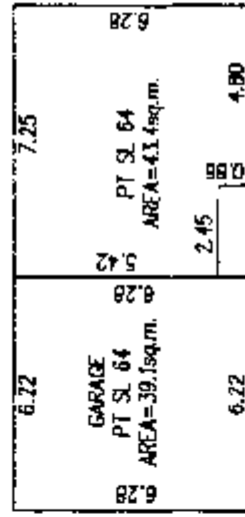

BUILDING 19

G.A.R.

DATED THIS 10<sup>th</sup> DAY OF JAN. 2002

B.C.L.S.



FLOOR PLANS

STRATA PLAN LMS3841  
PHASE 2

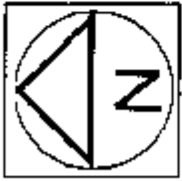
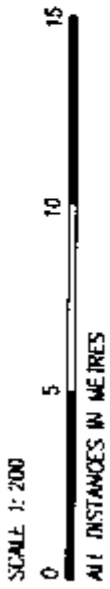

BUILDING 14

MAIN FLOOR

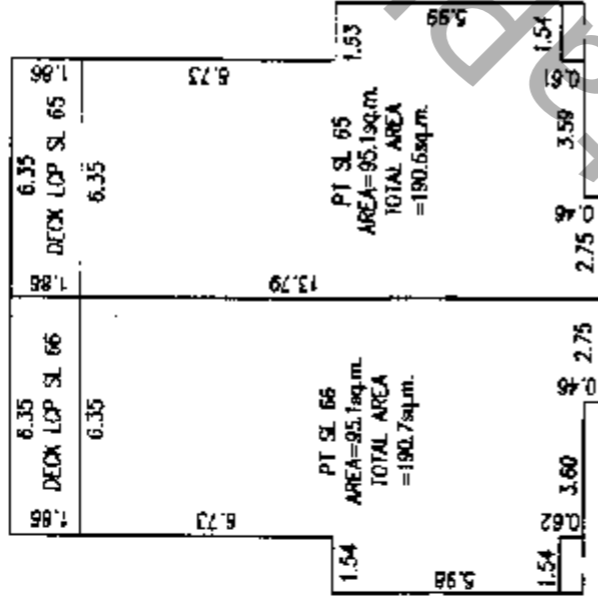

GROUND FLOOR

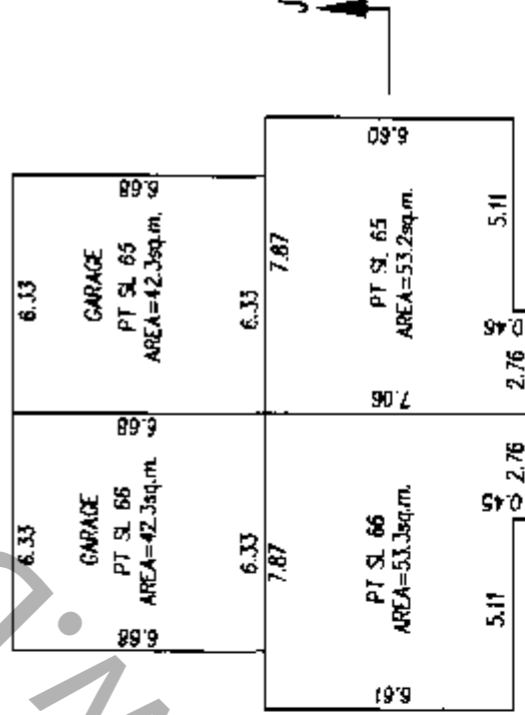

DATED THIS 10<sup>th</sup> DAY OF JAN. 2002  
G.A.R.  
B.C.L.S.

SCALE 1:200



ALL DISTANCES IN METRES

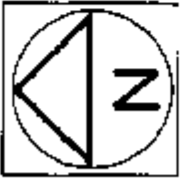

FLOOR PLANS

STRATA PLAN LMS3841

PHASE 2

BUILDING 12

MAIN FLOOR

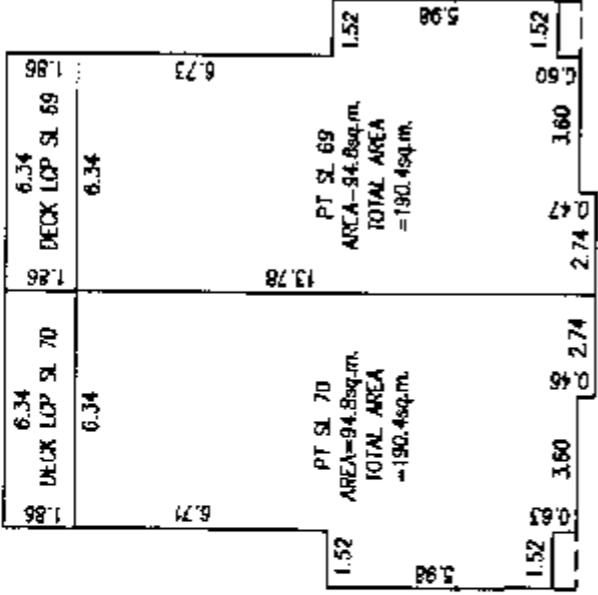

BUILDING 13

MAIN FLOOR

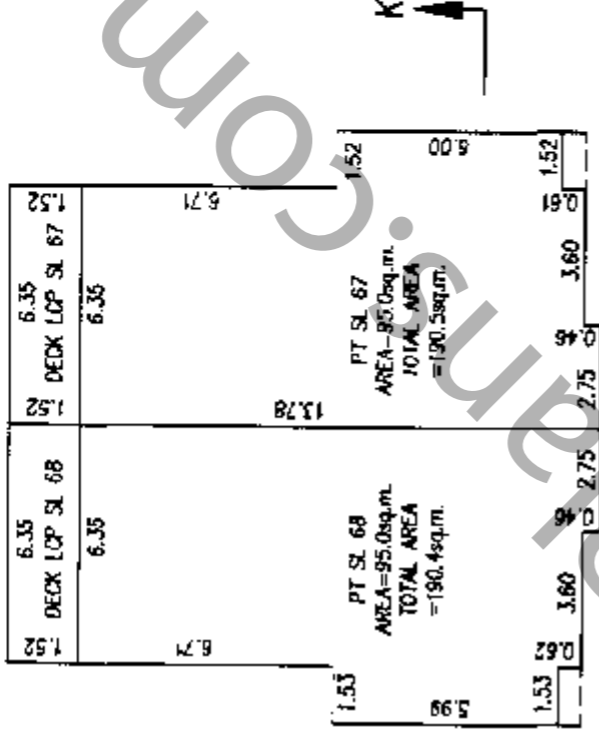

GROUND FLOOR

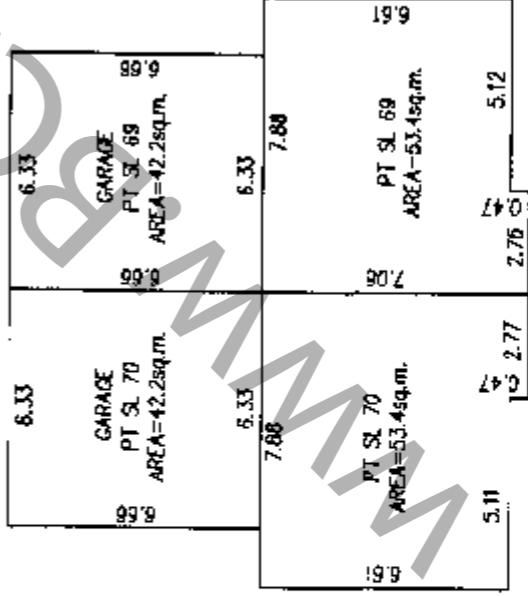

GROUND FLOOR

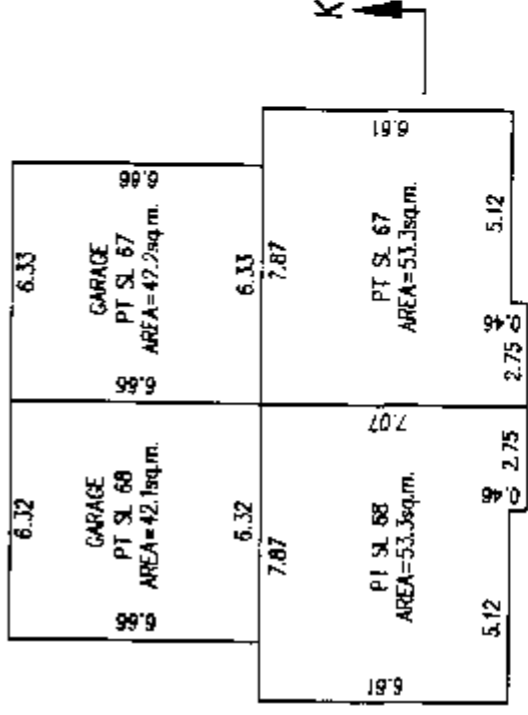

G.A.R.

B.C.I.S.

DATED THIS 10<sup>th</sup> DAY OF JAN 2002

# SECTIONS STRATA PLAN LMS3841 PHASE 2



## SECTION A-A

### BUILDING 35

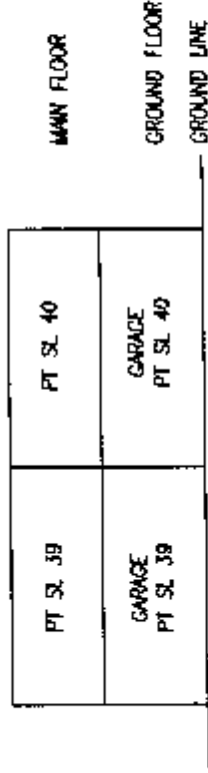

## SECTION B-B

### BUILDING 34

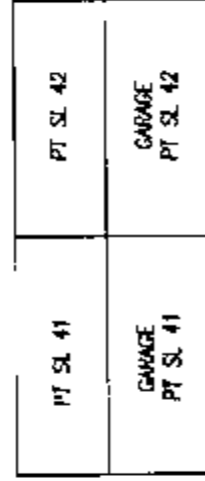

### BUILDING 33

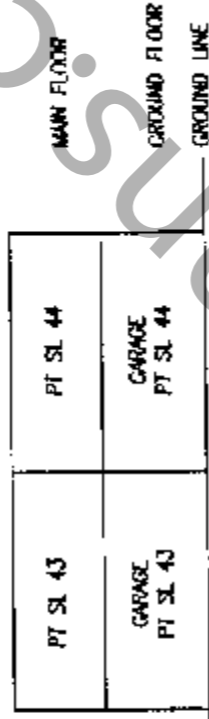

## SECTION C-C

### BUILDING 23

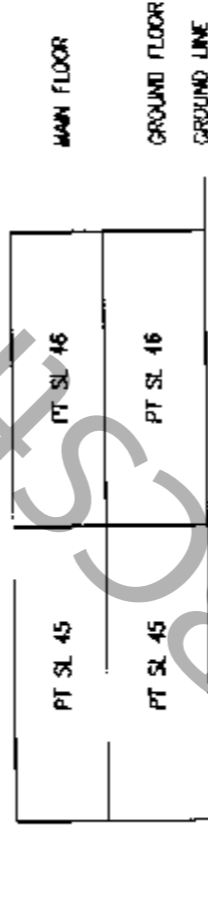

## SECTION D-D

### BUILDING 25

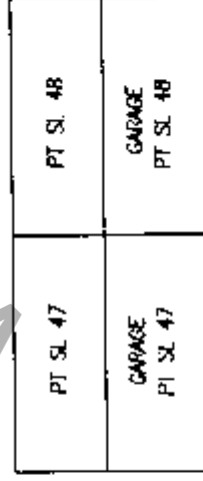

### BUILDING 25

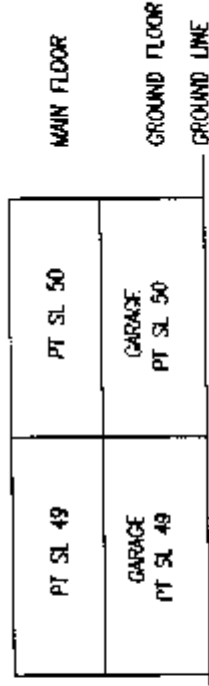

G.A.R.

DATED THIS 10<sup>th</sup> DAY OF JAN. 2002

B.C.L.S.

# SECTIONS STRATA PLAN LMS3841 PHASE 2

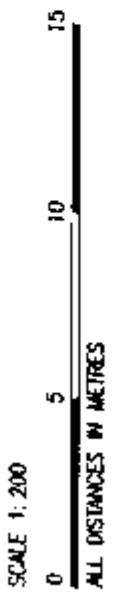

## SECTION E-E

BUILDING 27

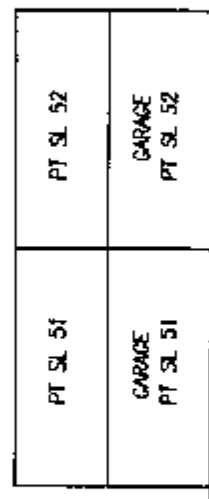

BUILDING 28

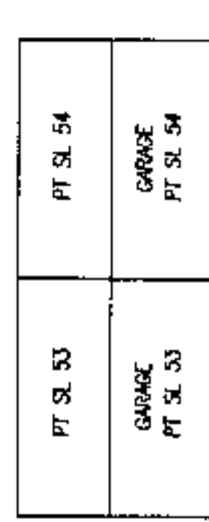

MAIN FLOOR  
GROUND FLOOR  
GROUND LINE

## SECTION F-F

BUILDING 32

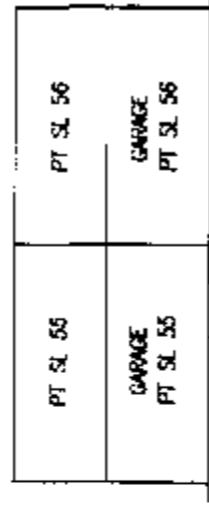

MAIN FLOOR  
GROUND FLOOR  
GROUND LINE

## SECTION G-G

BUILDING 17

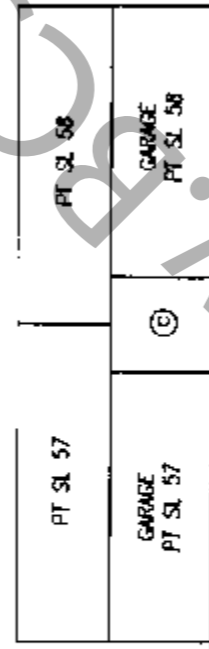

BUILDING 18

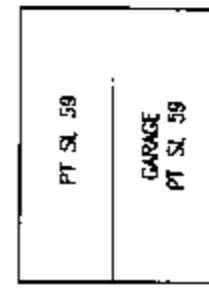

MAIN FLOOR  
GROUND FLOOR  
GROUND LINE

## SECTION H-H

BUILDING 24

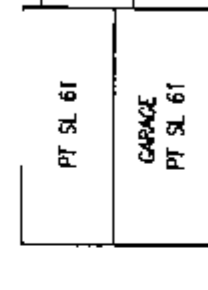

MAIN FLOOR  
GROUND FLOOR  
GROUND LINE

G.A.R.  
 DATED THIS 10<sup>th</sup> DAY OF JAN. 2002  
 B.C.L.S.

# STRATA PLAN LMS3841 PHASE 2

## SECTIONS



### SECTION I-I

BUILDING 19

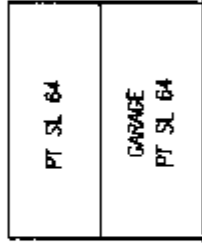

BUILDING 20

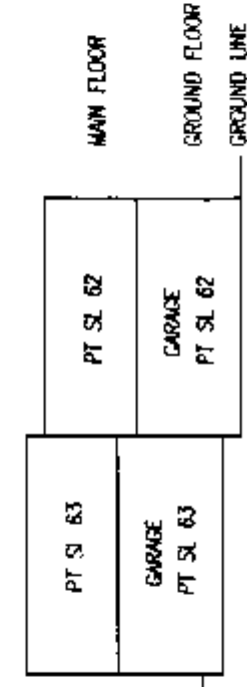

### SECTION J-J

BUILDING 14

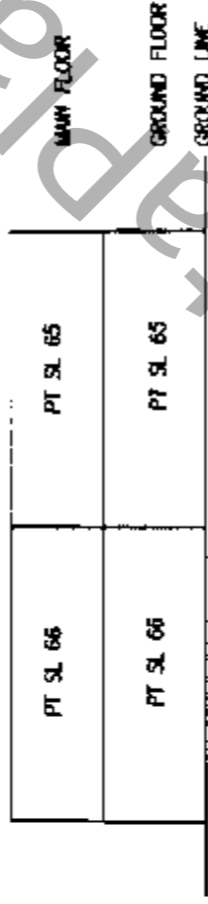

### SECTION K-K

BUILDING 12

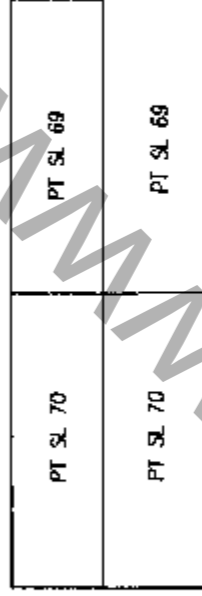

BUILDING 13

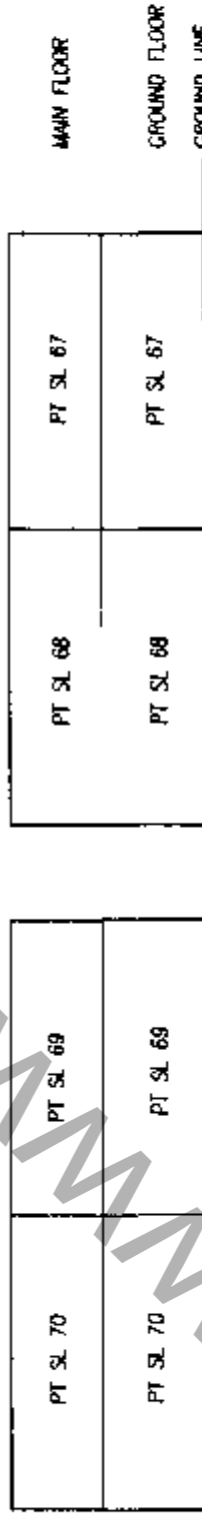

G.A.R.

B.C.L.S.

DATED THIS 10<sup>th</sup> DAY OF JAN. 2002