

STRATA PLAN OF LOT C SECTION 23 BLOCK 5 NORTH RANGE 2 WEST NEW WESTMINSTER DISTRICT PLAN BCP31151

SHEET 1 OF 16 SHEETS

STRATA PLAN EPS5304

B.C.G.S. 92G.016
CITY OF SURREY

#13768 108TH AVENUE,
SURREY, B.C.
P.I.D 027-121-127

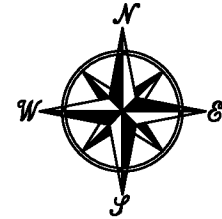

The intended plot size of this plan is 432mm in width by 280mm in height (B size) when plotted at a scale of 1 : 500

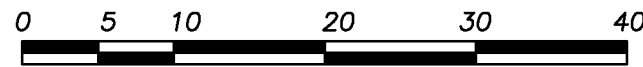

ALL DISTANCES ARE IN METRES AND DECIMALS THEREOF UNLESS OTHERWISE INDICATED

LEGEND:

- Control Monument Found
- Iron post Found
- L.C.P. denotes limited common property
- S.L. denotes strata lot
- C.P. denotes common property
- C.F. denotes common facility
- E/C denotes electrical room
- denotes line of floor below
- VEST denotes vestibule

NOTE:
Balcony, patio areas are defined as to height by the center of the floor above or its extensions, or where there is no floor above by the average height of strata lots within the same building, unless otherwise noted.

J. C. Tam and Associates
Canada and B.C. Land Surveyor
115 - 8833 Odlin Crescent
Richmond, B.C. V6X 3Z7
Telephone: 214-8928
Fax: 214-8929
E-mail: office@jctam.com
Website: www.jctam.com
File: 5553-FS

5361
UTM ZONE 10 Coordinates
DATUM: NAD83 (CSRS) 4.0.0.BC.1.GVRD
UTM NORTHING: 5449424.438 m
UTM EASTING: 511483.787 m
POINT SCALE FACTOR: 0.9995896
ESTIMATED HORIZONTAL POSITIONAL ACCURACY: 0.018m

5362
UTM ZONE 10 Coordinates
DATUM: NAD83 (CSRS) 4.0.0.BC.1.GVRD
UTM NORTHING: 5449420.921 m
UTM EASTING: 511682.382 m
POINT SCALE FACTOR: 0.9995880
ESTIMATED HORIZONTAL POSITIONAL ACCURACY: 0.021m

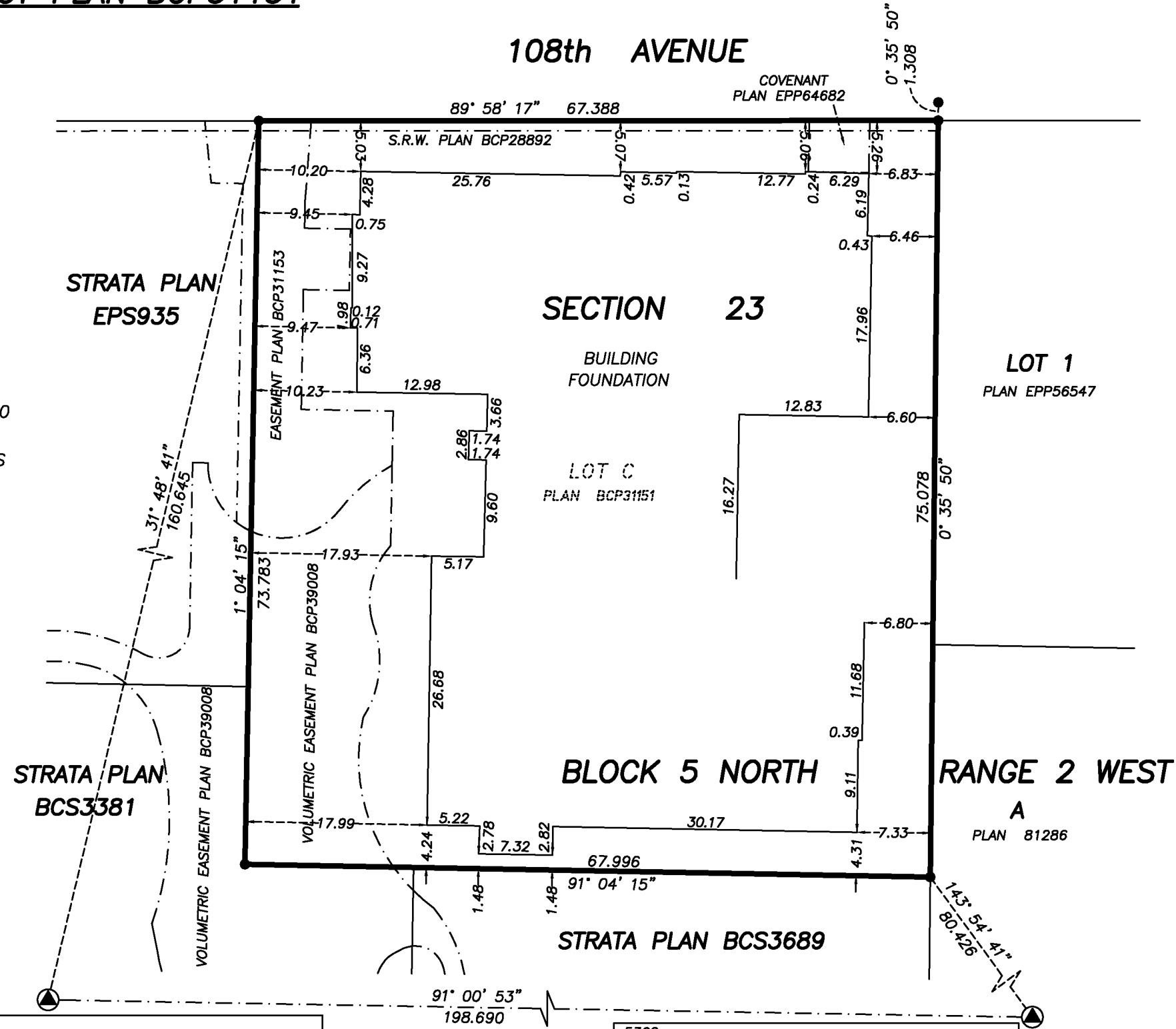

NOTE:
Dimensions are shown to exterior of concrete foundation except where otherwise noted..

The buildings included in this strata plan have not been previously occupied.

The buildings shown hereon are within the external boundaries of the land that is the subject of the strata plan.

The UTM coordinates and estimated horizontal positional accuracy achieved are derived from the MASCOT published coordinates and standard deviations for geodetic control monuments 5361 and 5362.

Integrated Survey Area No. 1 (SURREY), AD83(CSRS) 4.0.0.BC.1.GVRD. Grid bearings are derived from observations between geodetic control monuments 5361 and 5362.

This plan shows horizontal ground level distance except where otherwise noted. To compute grid distance, multiply ground-level distance by the combined factor of 0.9995888 which has been derived from 5361 and 5362.

This plan lies within the City of Surrey.

This plan lies within the Metro Vancouver Regional District.

The field survey represented by this plan was completed on the 22nd day of August, 2018. Johnson C. Tam, B.C.L.S 711.

PARKADE P3 (NORTH SIDE)

SHEET 2 OF 16 SHEETS

STRATA PLAN EPS5304

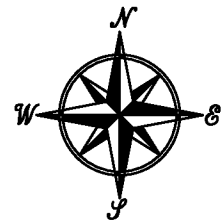

THE INTENDED PLOT SIZE OF THIS PLAN IS 432mm IN WIDTH BY 280mm IN HEIGHT (B SIZE) WHEN PLOTTED AT A SCALE OF 1 : 200



ALL DISTANCES ARE IN METRES AND DECIMALS THEREOF UNLESS OTHERWISE INDICATED

NOTE:
Dimensions are shown to centreline of all walls except where otherwise noted.

Section arrows on this plan point in the direction of view.

EASEMENT PLAN BCP31153

LOCKERS ROOM C.P.

STAIRS C.P.

VEST C.P.

ELEVATOR LOBBY C.P.

ELEVATOR C.P.

ELEVATOR MACHINE ROOM C.P.

SPARE SPRINKLER ROOM C.P.

PARKING C.P.
"OPTION TO LEASE"
EXP. PLAN EPP85710

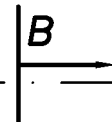

Match Line

Match Line

J. C. Tam and Associates
Canada and B.C. Land Surveyor
115 - 8833 Odlin Crescent
Richmond, B.C. V6X 3Z7
Telephone: 214-8928
Fax: 214-8929
E-mail: office@jctam.com
Website: www.jctam.com
File: 5553-FS

JOHNSON C. TAM, B.C.L.S.
September 17th, 2018.

PARKADE P3 (SOUTH SIDE)

SHEET 3 OF 16 SHEETS

STRATA PLAN EPS5304

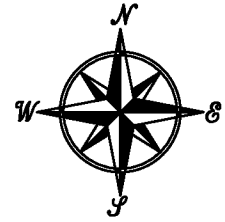

THE INTENDED PLOT SIZE OF THIS PLAN IS 432mm
IN WIDTH BY 280mm IN HEIGHT (B SIZE) WHEN
PLOTTED AT A SCALE OF 1 : 200



**ALL DISTANCES ARE IN METRES AND DECIMALS
THEREOF UNLESS OTHERWISE INDICATED**

NOTE:
Dimensions are shown to centreline of all
walls except where otherwise noted.

Section arrows on this plan point in the
direction of view.

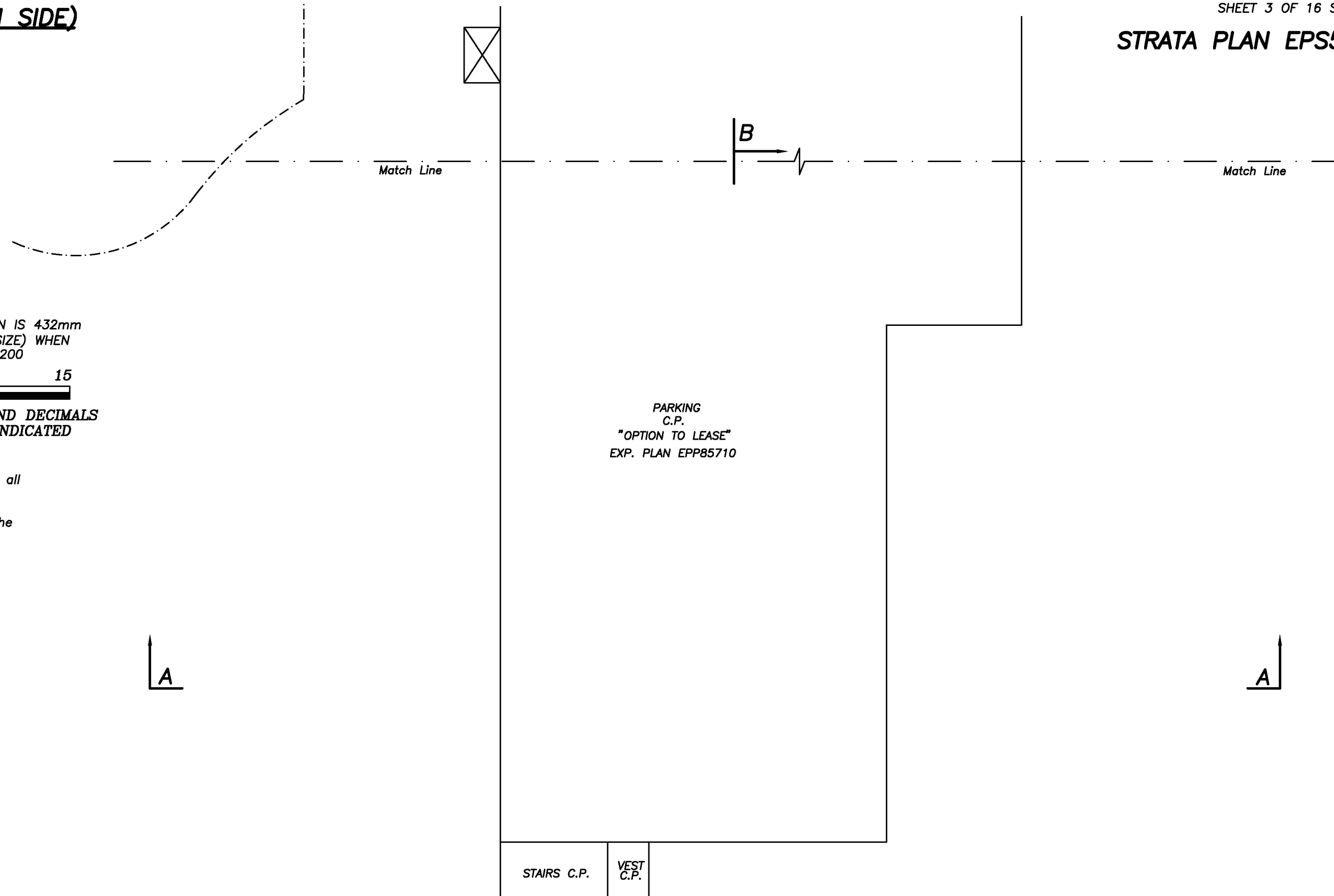

PARKING
C.P.
"OPTION TO LEASE"
EXP. PLAN EPP85710

STAIRS C.P.

VEST
C.P.

J. C. Tam and Associates
Canada and B.C. Land Surveyor
115 - 8833 Odlin Crescent
Richmond, B.C. V6X 3Z7
Telephone: 214-8928
Fax: 214-8929
E-mail: office@jctam.com
Website: www.jctam.com
File: 5553-FS

JOHNSON C. TAM, B.C.L.S.
September 17th, 2018.

PARKADE P2 (NORTH SIDE)

SHEET 4 OF 16 SHEETS

STRATA PLAN EPS5304

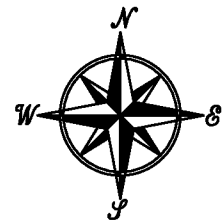

THE INTENDED PLOT SIZE OF THIS PLAN IS 432mm IN WIDTH BY 280mm IN HEIGHT (B SIZE) WHEN PLOTTED AT A SCALE OF 1 : 200



ALL DISTANCES ARE IN METRES AND DECIMALS THEREOF UNLESS OTHERWISE INDICATED

NOTE:
Dimensions are shown to centreline of all walls except where otherwise noted.

Section arrows on this plan point in the direction of view.

EASEMENT PLAN BCP31153

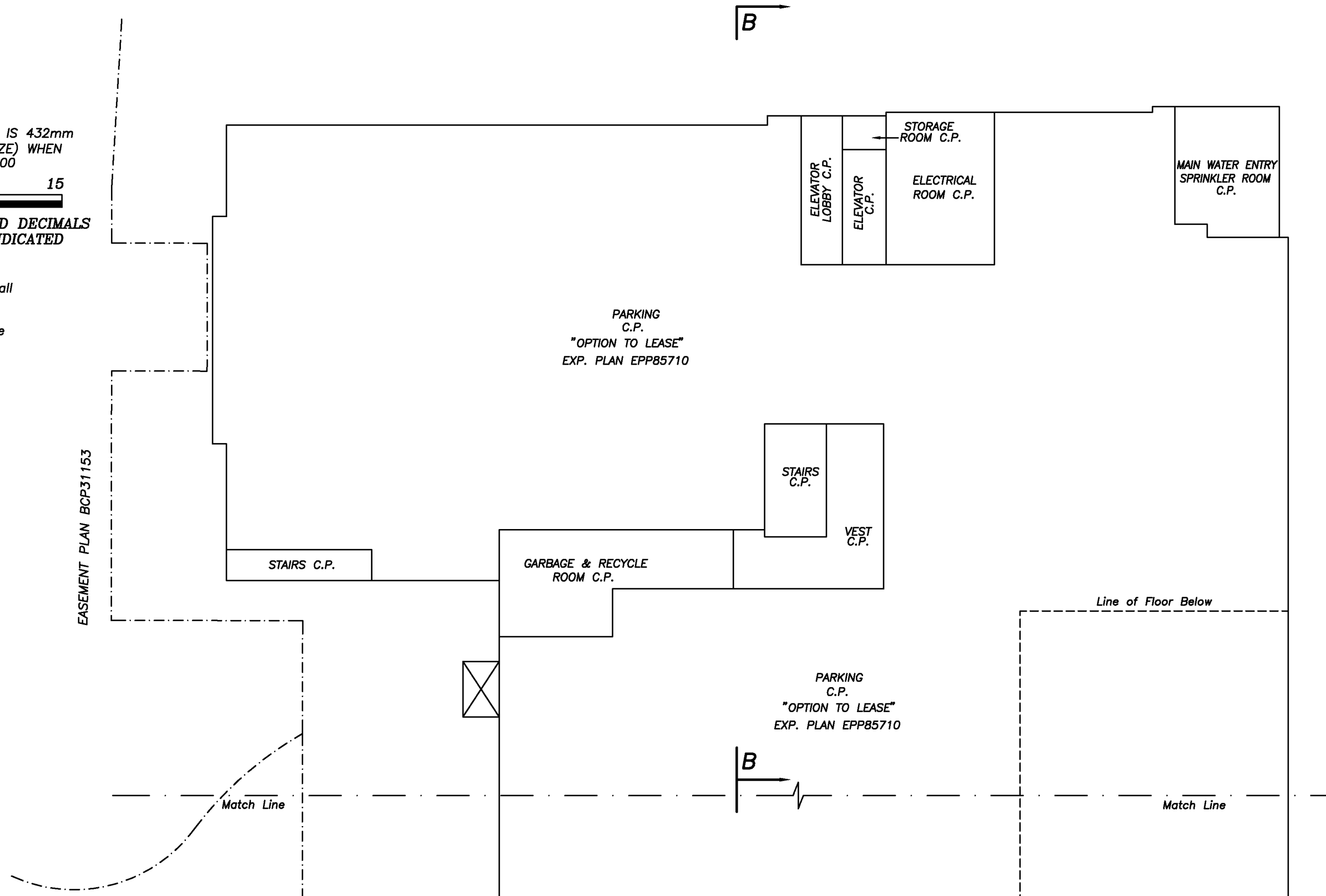

J. C. Tam and Associates
Canada and B.C. Land Surveyor
115 - 8833 Odlin Crescent
Richmond, B.C. V6X 3Z7
Telephone: 214-8928
Fax: 214-8929
E-mail: office@jctam.com
Website: www.jctam.com
File: 5553-FS

JOHNSON C. TAM, B.C.L.S.
September 17th, 2018.

PARKADE P2 (SOUTH SIDE)

SHEET 5 OF 16 SHEETS

STRATA PLAN EPS5304

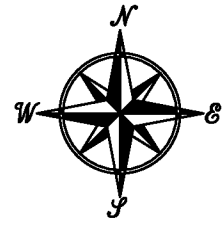

PARKING
C.P.
"OPTION TO LEASE"
EXP. PLAN EPP85710

Match Line

Match Line

THE INTENDED PLOT SIZE OF THIS PLAN IS 432mm
IN WIDTH BY 280mm IN HEIGHT (B SIZE) WHEN
PLOTTED AT A SCALE OF 1 : 200



ALL DISTANCES ARE IN METRES AND DECIMALS
THEREOF UNLESS OTHERWISE INDICATED

NOTE:
Dimensions are shown to centreline of all
walls except where otherwise noted.

Section arrows on this plan point in the
direction of view.

VOLUMETRIC EASEMENT PLAN BCP39008

BICYCLE
STORAGE
ROOM C.P.

PARKING
C.P.
"OPTION TO LEASE"
EXP. PLAN EPP85710

Line of Floor Below



STORAGE
ROOM C.P.

STORAGE
ROOM C.P.

STAIRS C.P.

VEST
C.P.



J. C. Tam and Associates
Canada and B.C. Land Surveyor
115 - 8833 Odlin Crescent
Richmond, B.C. V6X 3Z7
Telephone: 214-8928
Fax: 214-8929
E-mail: office@jctam.com
Website: www.jctam.com
File: 5553-FS

JOHNSON C. TAM, B.C.L.S.
September 17th, 2018.

PARKADE P1/LEVEL 1 (NORTH SIDE)

SHEET 6 OF 16 SHEETS

STRATA LOTS 1 TO 9

STRATA PLAN EPS5304

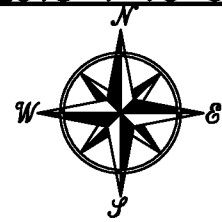

THE INTENDED PLOT SIZE OF THIS PLAN IS 432mm IN WIDTH BY 280mm IN HEIGHT (B SIZE) WHEN PLOTTED AT A SCALE OF 1 : 200



ALL DISTANCES ARE IN METRES AND DECIMALS THEREOF UNLESS OTHERWISE INDICATED

NOTE: Dimensions are shown to centreline of all walls except where otherwise noted.

Section arrows on this plan point in the direction of view.

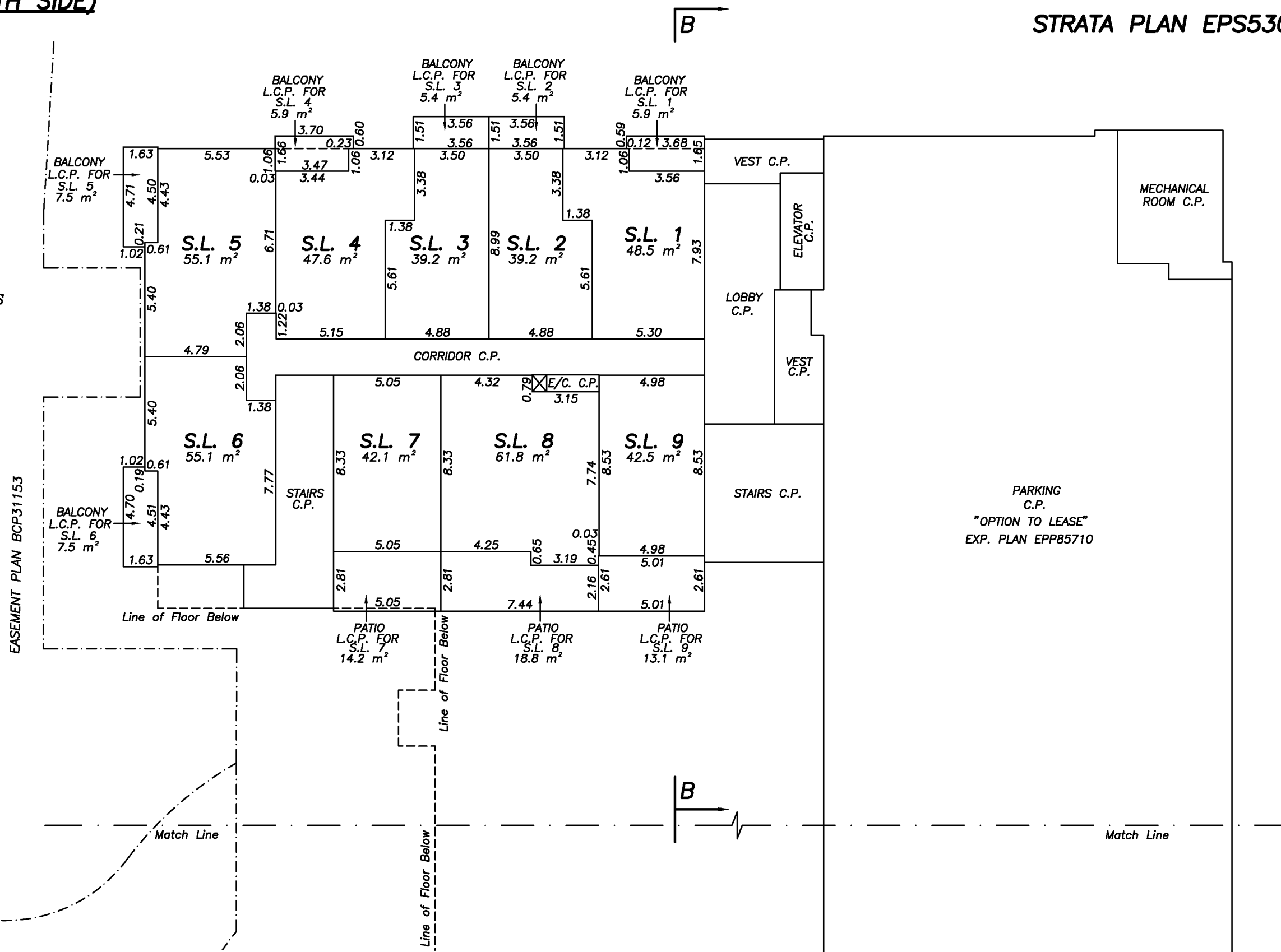

J. C. Tam and Associates
 Canada and B.C. Land Surveyor
 115 - 8833 Odlin Crescent
 Richmond, B.C. V6X 3Z7
 Telephone: 214-8928
 Fax: 214-8929
 E-mail: office@jctam.com
 Website: www.jctam.com
 File: 5553-FS

JOHNSON C. TAM, B.C.L.S.
 September 17th, 2018.

PARKADE P1/LEVEL 1 (SOUTH SIDE)

SHEET 7 OF 16 SHEETS

STRATA PLAN EPS5304

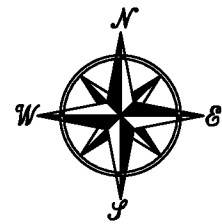

Match Line

Match Line

THE INTENDED PLOT SIZE OF THIS PLAN IS 432mm IN WIDTH BY 280mm IN HEIGHT (B SIZE) WHEN PLOTTED AT A SCALE OF 1 : 200



ALL DISTANCES ARE IN METRES AND DECIMALS THEREOF UNLESS OTHERWISE INDICATED

NOTE:
Dimensions are shown to centreline of all walls except where otherwise noted.

Section arrows on this plan point in the direction of view.

VOLUMETRIC EASEMENT PLAN BCP99008

Line of Floor Below

B

A

A

BICYCLE STORAGE ROOM C.P.

PARKING C.P.
"OPTION TO LEASE"
EXP. PLAN EPP85710

TEL. ROOM C.P.

VEST C.P.

STAIRS C.P.

B

J. C. Tam and Associates
Canada and B.C. Land Surveyor
115 - 8833 Odlin Crescent
Richmond, B.C. V6X 3Z7
Telephone: 214-8928
Fax: 214-8929
E-mail: office@jctam.com
Website: www.jctam.com
File: 5553-FS

JOHNSON C. TAM, B.C.L.S.
September 17th, 2018.

LEVEL 2 (NORTH SIDE)

SHEET 8 OF 16 SHEETS

STRATA LOTS 10 TO 19 AND 36 TO 42

STRATA PLAN EPS5304

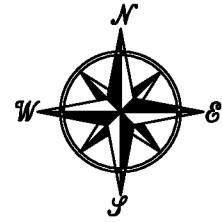

THE INTENDED PLOT SIZE OF THIS PLAN IS 432mm IN WIDTH BY 280mm IN HEIGHT (B SIZE) WHEN PLOTTED AT A SCALE OF 1 : 200



ALL DISTANCES ARE IN METRES AND DECIMALS THEREOF UNLESS OTHERWISE INDICATED

NOTE: Dimensions are shown to centreline of all walls except where otherwise noted.

Section arrows on this plan point in the direction of view.

EASEMENT PLAN BCP31153

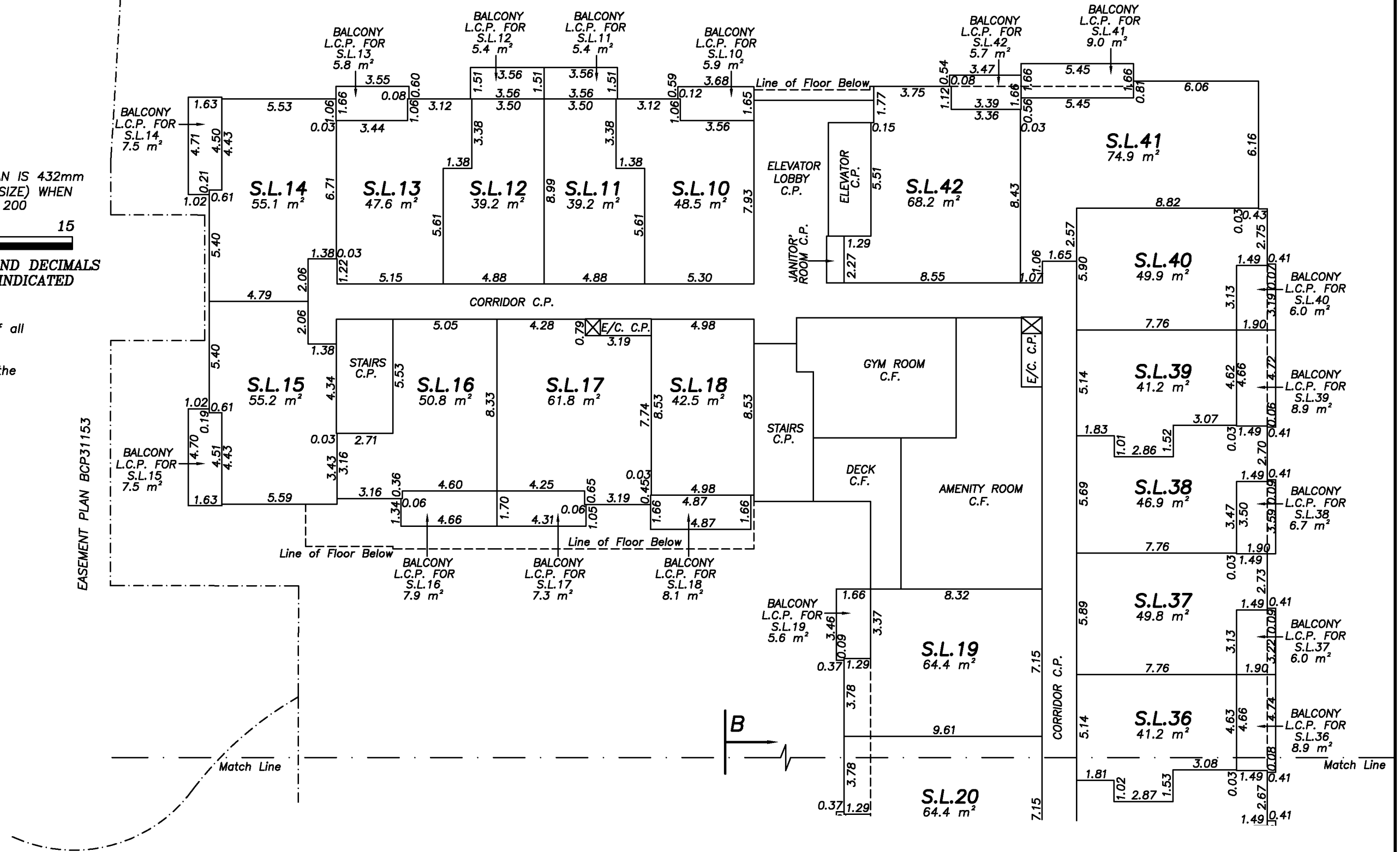

J. C. Tam and Associates
Canada and B.C. Land Surveyor
115 - 8833 Odlin Crescent
Richmond, B.C. V6X 3Z7
Telephone: 214-8928
Fax: 214-8929
E-mail: office@jctam.com
Website: www.jctam.com
File: 5553-FS

JOHNSON C. TAM, B.C.L.S.
September 17th, 2018.

LEVEL 2 (SOUTH SIDE)

STRATA LOTS 20 TO 35

SHEET 9 OF 16 SHEETS

STRATA PLAN EPS5304

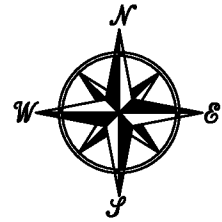

Match Line

Match Line

THE INTENDED PLOT SIZE OF THIS PLAN IS 432mm IN WIDTH BY 280mm IN HEIGHT (B SIZE) WHEN PLOTTED AT A SCALE OF 1 : 200



ALL DISTANCES ARE IN METRES AND DECIMALS THEREOF UNLESS OTHERWISE INDICATED

NOTE: Dimensions are shown to centreline of all walls except where otherwise noted.

Section arrows on this plan point in the direction of view.

VOLUMETRIC EASEMENT PLAN BCP39008

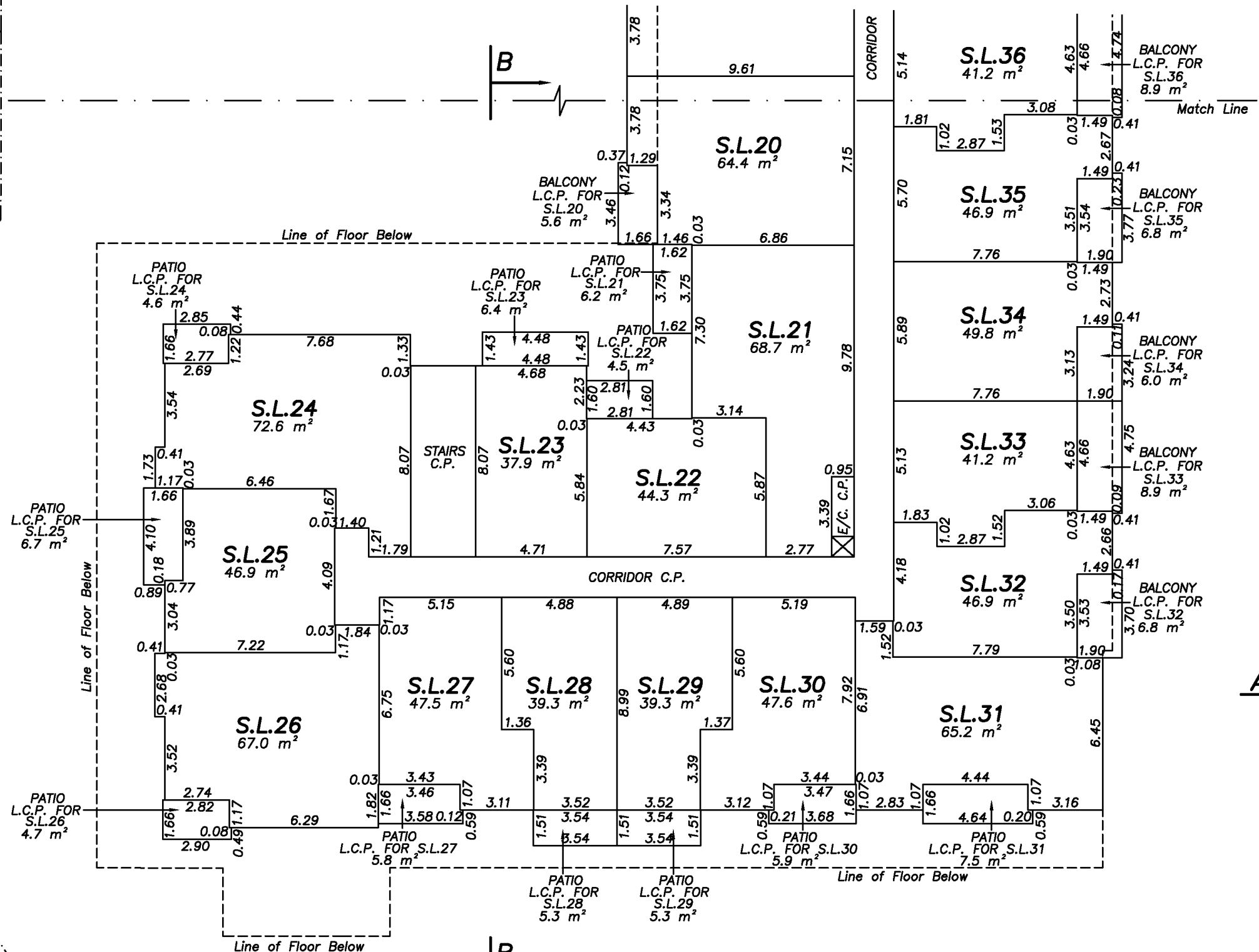

J. C. Tam and Associates
Canada and B.C. Land Surveyor
115 - 8833 Odlin Crescent
Richmond, B.C. V6X 3Z7
Telephone: 214-8928
Fax: 214-8929
E-mail: office@jctam.com
Website: www.jctam.com
File: 5553-FS

JOHNSON C. TAM, B.C.L.S.
September 17th, 2018.

LEVEL 3 (NORTH SIDE)

SHEET 10 OF 16 SHEETS

STRATA LOTS 43 TO 54 AND 71 TO 77

STRATA PLAN EPS5304

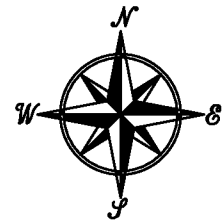

THE INTENDED PLOT SIZE OF THIS PLAN IS 432mm IN WIDTH BY 280mm IN HEIGHT (B SIZE) WHEN PLOTTED AT A SCALE OF 1 : 200



ALL DISTANCES ARE IN METRES AND DECIMALS THEREOF UNLESS OTHERWISE INDICATED

NOTE: Dimensions are shown to centreline of all walls except where otherwise noted.

Section arrows on this plan point in the direction of view.

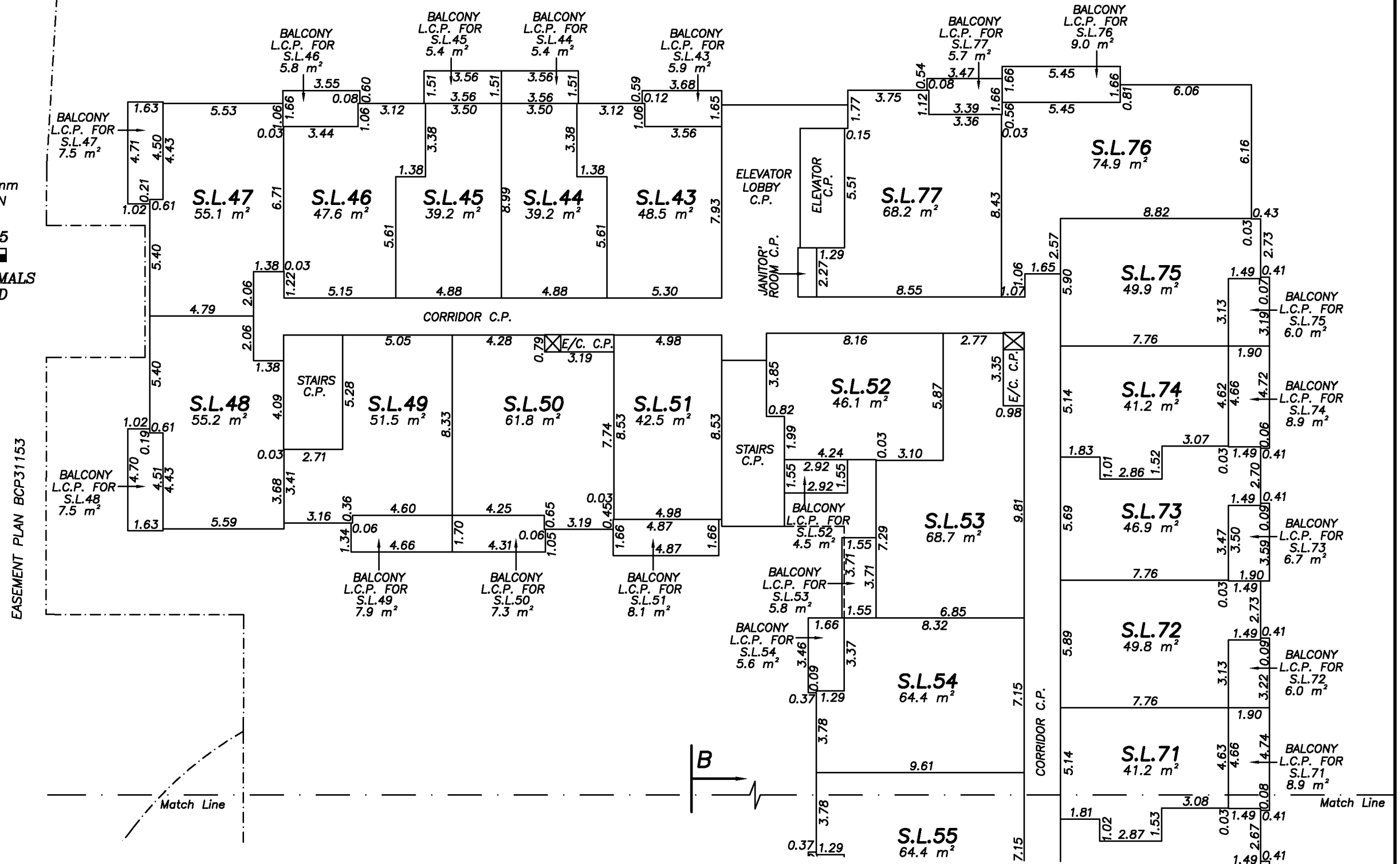

J. C. Tam and Associates
Canada and B.C. Land Surveyor
115 - 8833 Odlin Crescent
Richmond, B.C. V6X 3Z7
Telephone: 214-8928
Fax: 214-8929
E-mail: office@jctam.com
Website: www.jctam.com
File: 5553-FS

JOHNSON C. TAM, B.C.L.S.
September 17th, 2018.

LEVEL 3 (SOUTH SIDE)
STRATA LOTS 55 TO 70

SHEET 11 OF 16 SHEETS
STRATA PLAN EPS5304

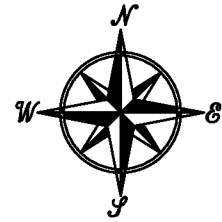

Match Line

Match Line

THE INTENDED PLOT SIZE OF THIS PLAN IS 432mm IN WIDTH BY 280mm IN HEIGHT (B SIZE) WHEN PLOTTED AT A SCALE OF 1 : 200



ALL DISTANCES ARE IN METRES AND DECIMALS THEREOF UNLESS OTHERWISE INDICATED

NOTE:
Dimensions are shown to centreline of all walls except where otherwise noted.

Section arrows on this plan point in the direction of view.

VOLUMETRIC EASEMENT PLAN BCP390008

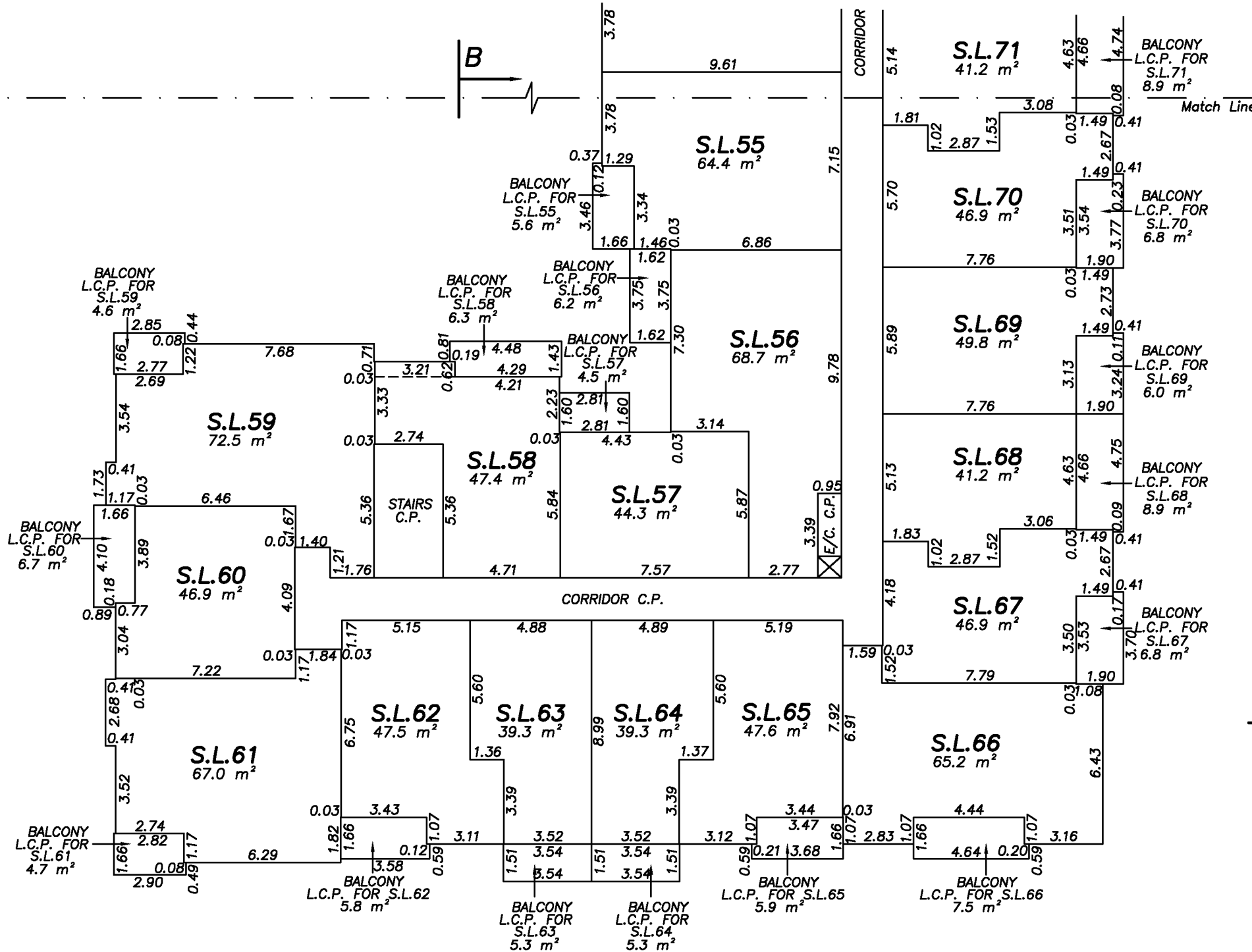

J. C. Tam and Associates
Canada and B.C. Land Surveyor
115 - 8833 Odlin Crescent
Richmond, B.C. V6X 3Z7
Telephone: 214-8928
Fax: 214-8929
E-mail: office@jctam.com
Website: www.jctam.com
File: 5553-FS

JOHNSON C. TAM, B.C.L.S.
September 17th, 2018.

LEVEL 4 (NORTH SIDE)

SHEET 12 OF 16 SHEETS

STRATA LOTS 78 TO 89 AND 106 TO 112

STRATA PLAN EPS5304

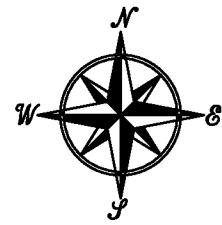

THE INTENDED PLOT SIZE OF THIS PLAN IS 432mm IN WIDTH BY 280mm IN HEIGHT (B SIZE) WHEN PLOTTED AT A SCALE OF 1 : 200



ALL DISTANCES ARE IN METRES AND DECIMALS THEREOF UNLESS OTHERWISE INDICATED

NOTE: Dimensions are shown to centreline of all walls except where otherwise noted.

Section arrows on this plan point in the direction of view.

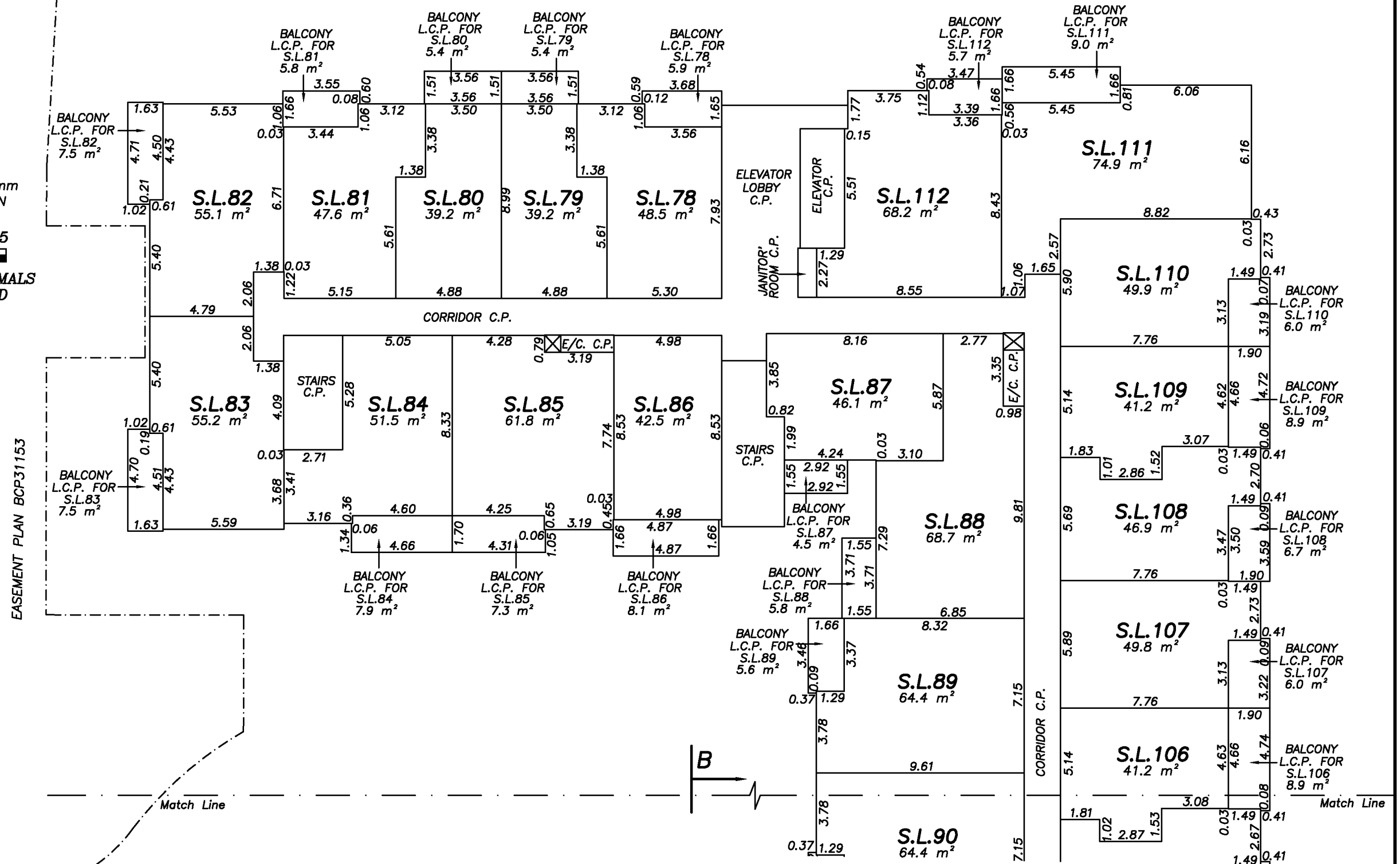

J. C. Tam and Associates
Canada and B.C. Land Surveyor
115 - 8833 Odlin Crescent
Richmond, B.C. V6X 3Z7
Telephone: 214-8928
Fax: 214-8929
E-mail: office@jctam.com
Website: www.jctam.com
File: 5553-FS

JOHNSON C. TAM, B.C.L.S.
September 17th, 2018.

LEVEL 4 (SOUTH SIDE)

STRATA LOTS 90 TO 105

SHEET 13 OF 16 SHEETS

STRATA PLAN EPS5304

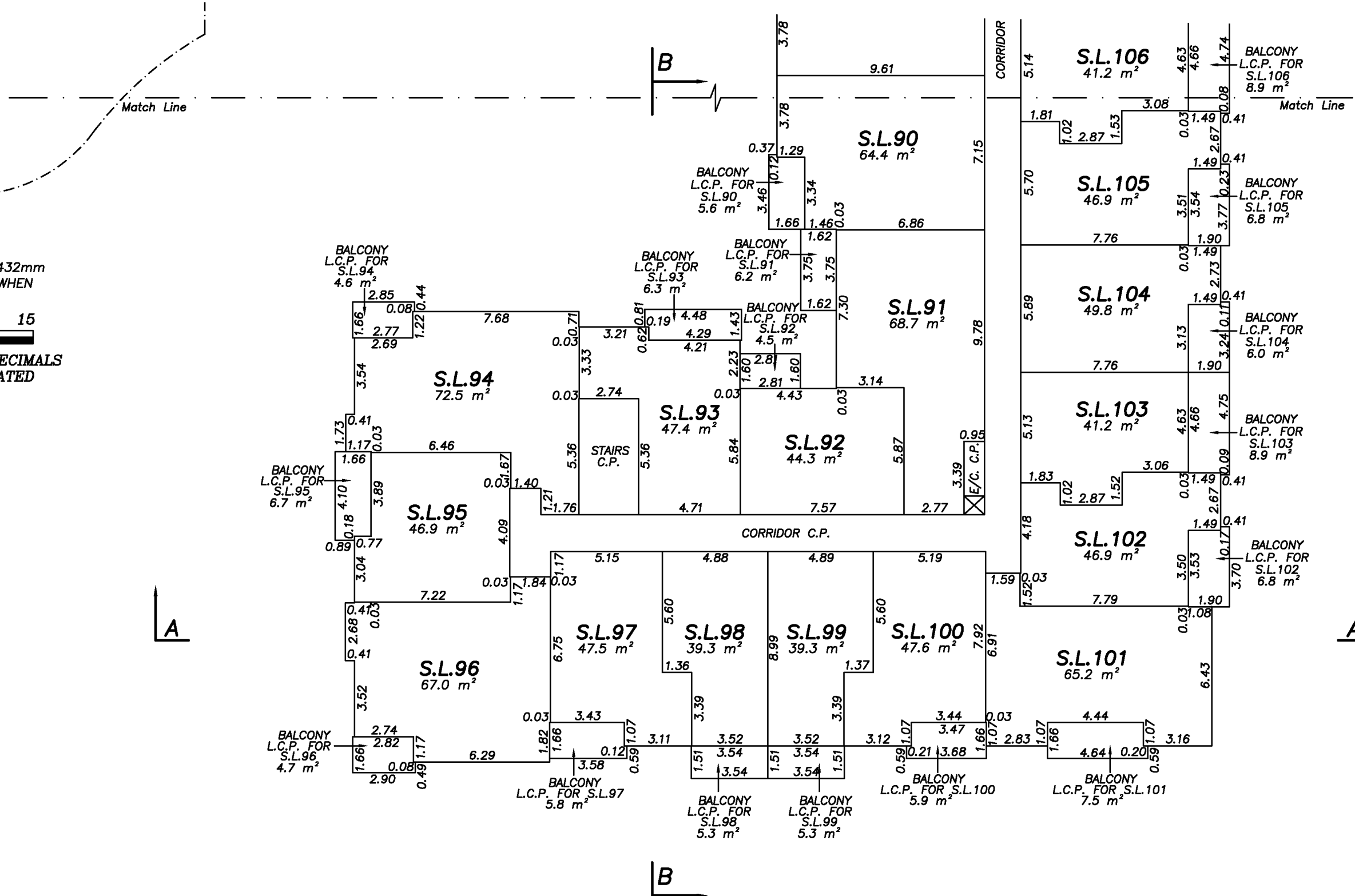
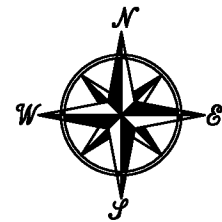

THE INTENDED PLOT SIZE OF THIS PLAN IS 432mm IN WIDTH BY 280mm IN HEIGHT (B SIZE) WHEN PLOTTED AT A SCALE OF 1 : 200



ALL DISTANCES ARE IN METRES AND DECIMALS THEREOF UNLESS OTHERWISE INDICATED

NOTE:
Dimensions are shown to centreline of all walls except where otherwise noted.

Section arrows on this plan point in the direction of view.

J. C. Tam and Associates
Canada and B.C. Land Surveyor
115 - 8833 Odlin Crescent
Richmond, B.C. V6X 3Z7
Telephone: 214-8928
Fax: 214-8929
E-mail: office@jctam.com
Website: www.jctam.com
File: 5553-FS

JOHNSON C. TAM, B.C.L.S.
September 17th, 2018.

LEVEL 5 (NORTH SIDE)

SHEET 14 OF 16 SHEETS

STRATA LOTS 113 TO 118 AND 135 TO 141

STRATA PLAN EPS5304

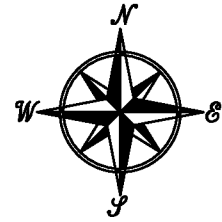

THE INTENDED PLOT SIZE OF THIS PLAN IS 432mm IN WIDTH BY 280mm IN HEIGHT (B SIZE) WHEN PLOTTED AT A SCALE OF 1 : 200



ALL DISTANCES ARE IN METRES AND DECIMALS THEREOF UNLESS OTHERWISE INDICATED

NOTE: Dimensions are shown to centreline of all walls except where otherwise noted.

Section arrows on this plan point in the direction of view.

EASEMENT PLAN BCP31153

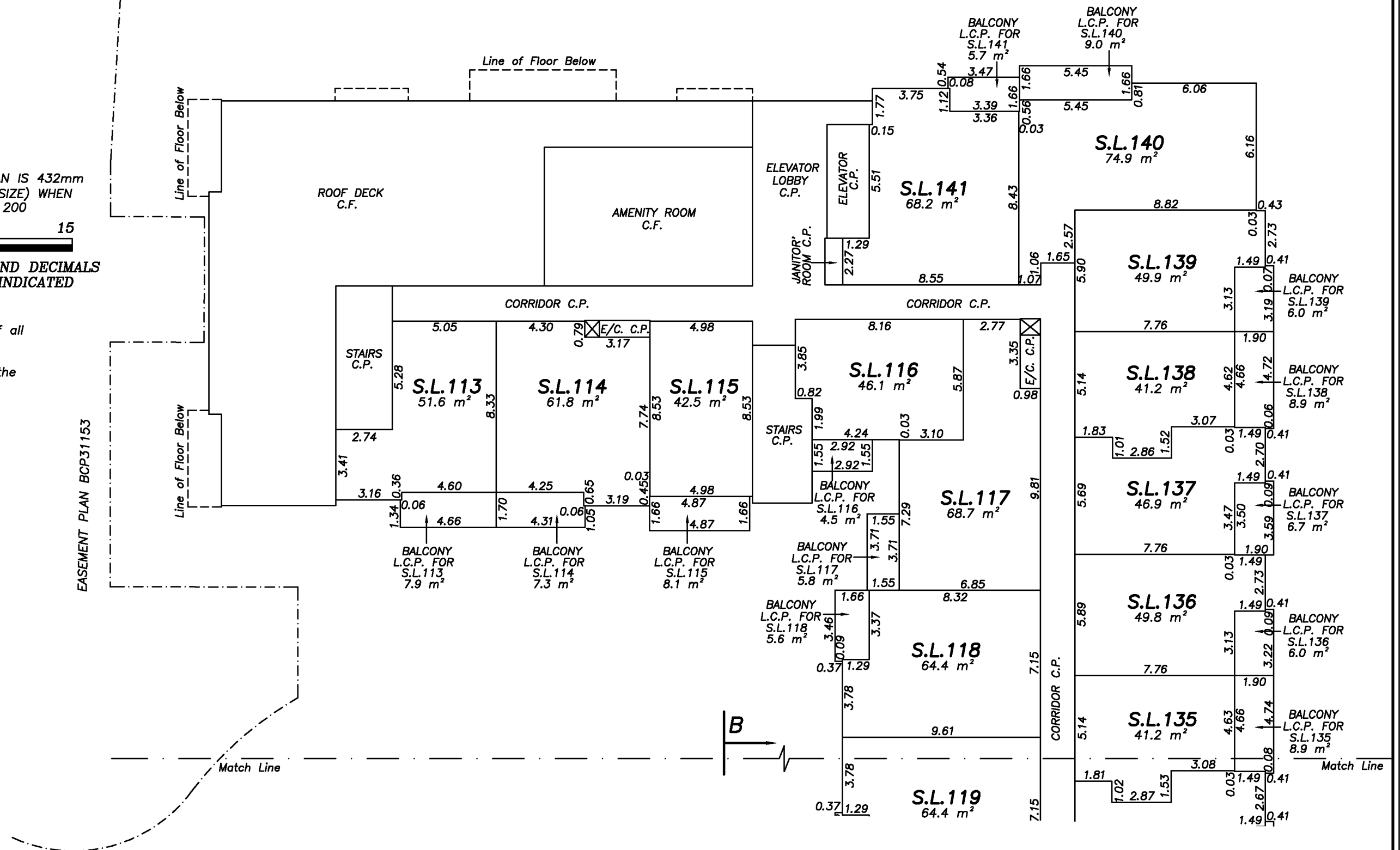

J. C. Tam and Associates
 Canada and B.C. Land Surveyor
 115 - 8833 Odlin Crescent
 Richmond, B.C. V6X 3Z7
 Telephone: 214-8928
 Fax: 214-8929
 E-mail: office@jctam.com
 Website: www.jctam.com
 File: 5553-FS

JOHNSON C. TAM, B.C.L.S.
 September 17th, 2018.

LEVEL 5 (SOUTH SIDE)

STRATA LOTS 119 TO 134

SHEET 15 OF 16 SHEETS

STRATA PLAN EPS5304

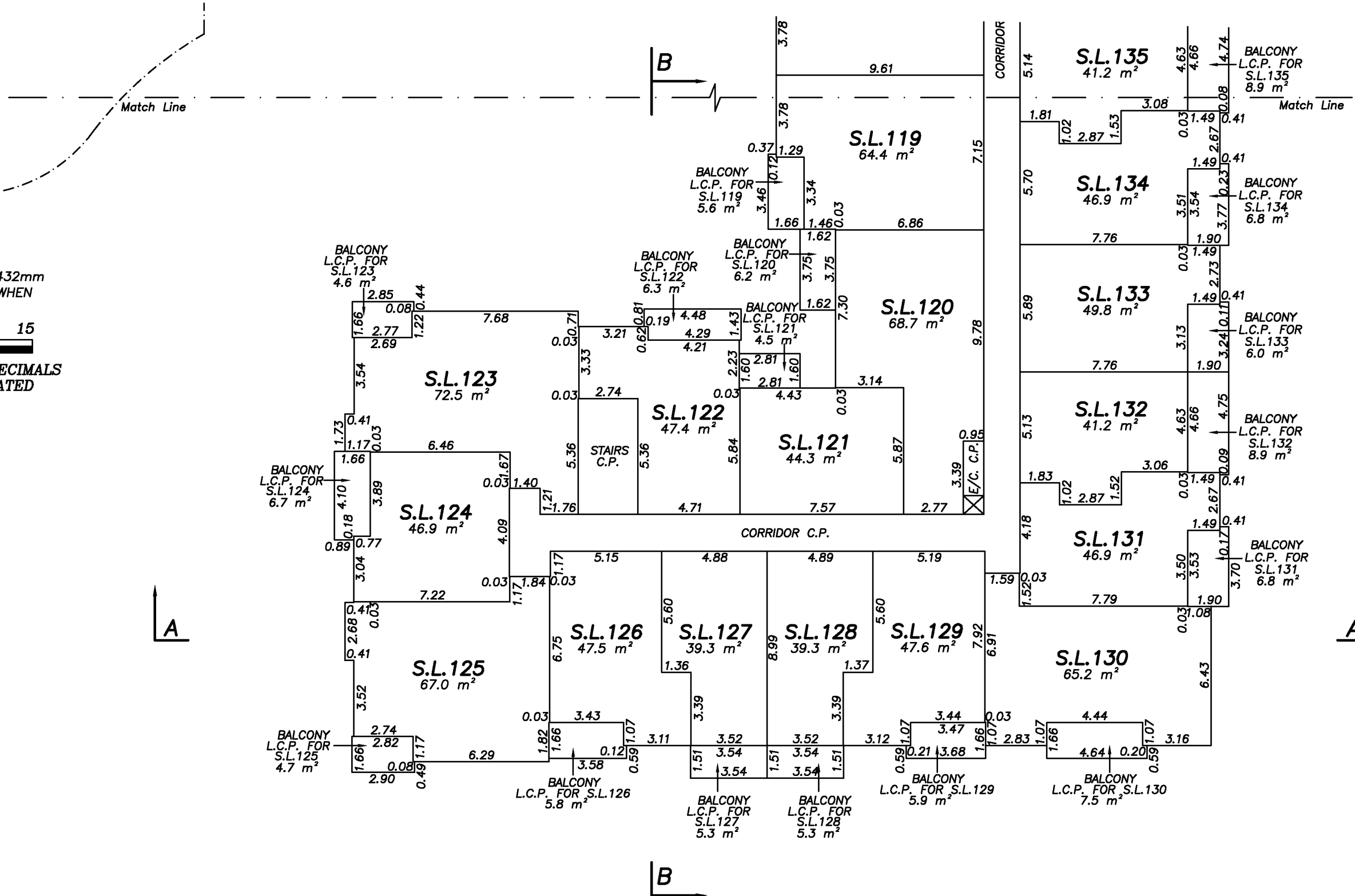
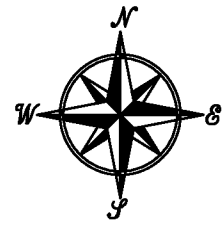

THE INTENDED PLOT SIZE OF THIS PLAN IS 432mm IN WIDTH BY 280mm IN HEIGHT (B SIZE) WHEN PLOTTED AT A SCALE OF 1 : 200



ALL DISTANCES ARE IN METRES AND DECIMALS THEREOF UNLESS OTHERWISE INDICATED

NOTE: Dimensions are shown to centreline of all walls except where otherwise noted.

Section arrows on this plan point in the direction of view.

J. C. Tam and Associates
Canada and B.C. Land Surveyor
115 - 8833 Odlin Crescent
Richmond, B.C. V6X 3Z7
Telephone: 214-8928
Fax: 214-8929
E-mail: office@jctam.com
Website: www.jctam.com
File: 5553-FS

JOHNSON C. TAM, B.C.L.S.
September 17th, 2018.

BUILDING SECTIONS

SHEET 16 OF 16 SHEETS
STRATA PLAN EPS5304

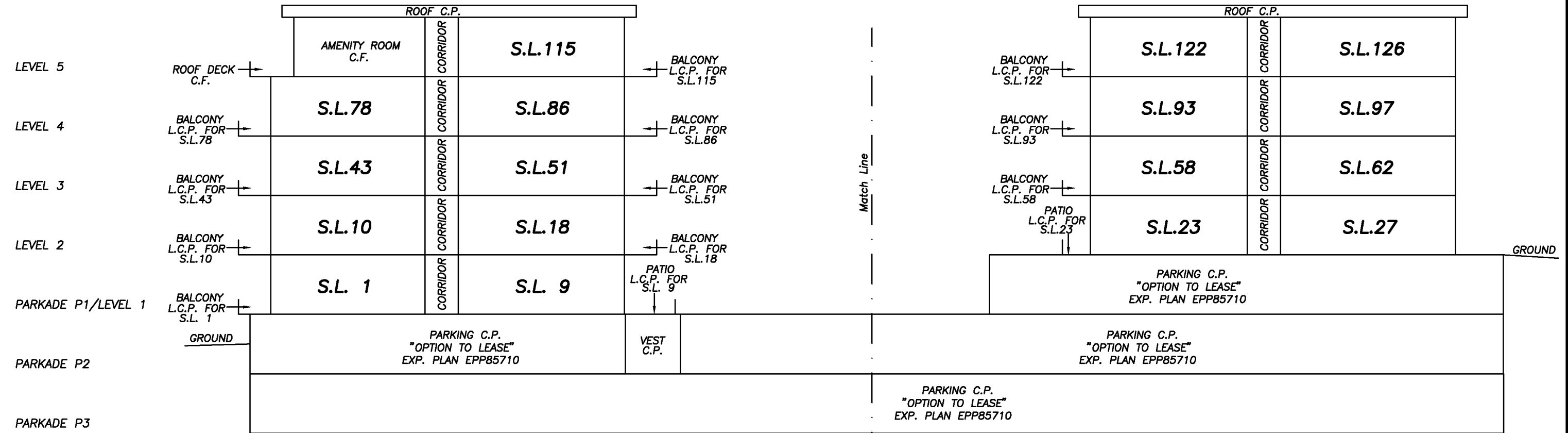

SECTION B - B

THE INTENDED PLOT SIZE OF THIS PLAN IS 432mm IN WIDTH BY 280mm IN HEIGHT (B SIZE) WHEN PLOTTED AT A SCALE OF 1 : 200



ALL DISTANCES ARE IN METRES AND DECIMALS THEREOF UNLESS OTHERWISE INDICATED

J. C. Tam and Associates
Canada and B.C. Land Surveyor
115 - 8833 Odlin Crescent
Richmond, B.C. V6X 3Z7
Telephone: 214-8928
Fax: 214-8929
E-mail: office@jctam.com
Website: www.jctam.com
File: 5553-FS

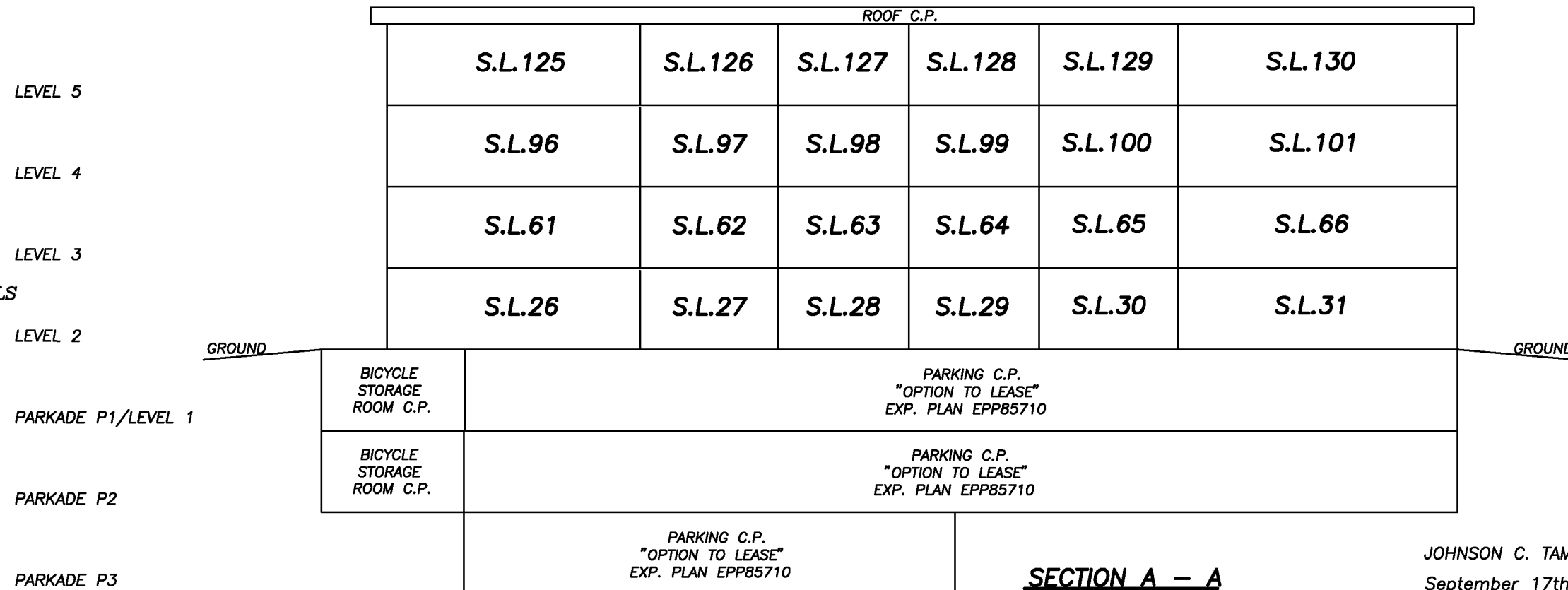

SECTION A - A

JOHNSON C. TAM, B.C.L.S.
September 17th, 2018.