

BC OnLine

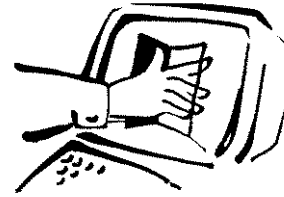

BC OnLine Land Title Internet Service
Provided in co-operation with
Land Title and Survey Authority

LAND TITLE AND SURVEY AUTHORITY - DOCUMENT RETRIEVAL		WEB REQUEST	
CLIENT NAME:	WESTECH APPRAISAL SERVICES LTD.		
ADDRESS:	130 - 144 WEST 14TH STREET NORTH VANCOUVER BC V7M 1P1		
PICK-UP INSTRUCTIONS:			
USER ID:	PA45000	APPLICATION NO.:	BCS1114 NW PAGES: 037
ACCOUNT NO.:	582952	REQUESTED AT:	06-10-27 14:28
REFERENCE NO.:	V69033	FOLIO NO.:	
REMARKS:			

BC OnLine Land Title Fax Service

Help Desk Victoria ... (250) 953-8200
In B.C. 1-800-663-6102
Administration Office ... (250) 953-8250
Fax Number (250) 953-8222

Persons who need to rely on a plan for legal purposes must examine the official version at the Land Title Office in which the plan is deposited.

The bylaw and common property sheets attached to strata plans have been repealed. Information regarding the bylaws and/or dealings affecting the common property of strata plans must be obtained from the general index and/or common property index on ALTOS. Refer to the BC OnLine user guide for access information.

PHASED STRATA PLAN OF A PORTION OF LOT 1,
DISTRICT LOTS 190 AND 235, GROUP 1,
NEW WESTMINSTER DISTRICT, PLAN BCP8948

STRATA PLAN BCS 1114

PHASE 1

DEPOSITED AND REGISTERED IN THE LAND TITLE OFFICE
AT NEW WESTMINSTER, B.C., JAN 13, 2005

Jan MacDonald / CP
REGISTRAR

SCALE-1:1000 THIS PLAN LIES WITHIN THE GREATER VANCOUVER REGIONAL DISTRICT



ALL DISTANCES ARE IN METRES

CIVIC ADDRESS

100 KLAHANIE DRIVE
CITY OF PORT MOODY

INTEGRATED SURVEY AREA
No.35 (CITY OF PORT MOODY) NAD83 (CSRS)

B.C.G.S. 92G 026



REM. PCL. "A"

R.P. 55526

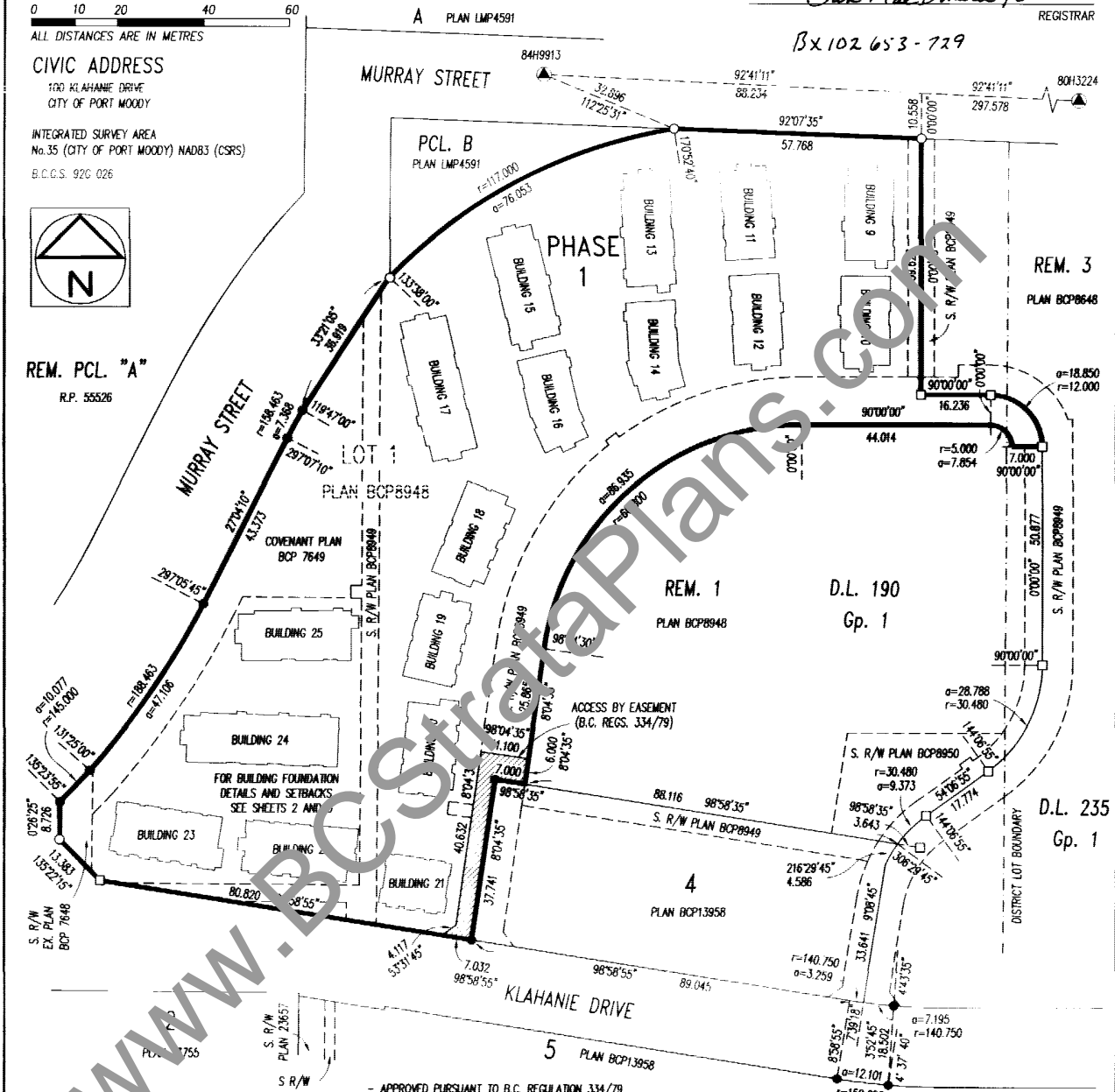

STRATA LOT ANGLES ARE 45° OR 90° UNLESS OTHERWISE NOTED.

THIS PLAN SHOWS GROUND LEVEL MEASURED DISTANCES.
PRIOR TO COMPUTATION OF UTM COORDINATES, MULTIPLY
BY THE COMBINED FACTOR 0.999603267.

GRID BEARINGS ARE DERIVED FROM
OLD CONTROL MONUMENTS 84H9913 AND 80H3224

LEGEND

- LOP INDICATES LIMITED COMMON PROPERTY
- sq.m. SQUARE METRES
- SL STRATA LOT
- PT PART
- ⊙ COMMON PROPERTY
- OLD IRON POST FOUND
- IRON POST SET
- ◻ OLD LEAD PLUG FOUND
- ◼ LEAD PLUG SET
- ⊙ OLD CONTROL MONUMENT FOUND

- APPROVED PURSUANT TO B.C. REGULATION 334/79
ACCESS BY EASEMENT

DATE January 25, 2005

John MacMillan
APPROVING OFFICER FOR THE CITY OF PORT MOODY

NOTE: "IRON POST SET" AND "LEAD PLUG SET" WERE SET FROM
PREVIOUS SURVEY CONTROL POINTS.

I, RON ESSON, A BRITISH COLUMBIA LAND SURVEYOR,
CERTIFY THAT THE BUILDINGS INCLUDED IN THE STRATA PLAN
HAVE NOT, AS OF October 23, 2004, BEEN
PREVIOUSLY OCCUPIED

RJ Esson B.C.L.S.

* SECTION 241 (2) PROVIDES THAT THE ENDORSEMENT MUST
BE DATED NOT MORE THAN 180 DAYS BEFORE THE DATE THE
STRATA PLAN IS TENDERED FOR DEPOSIT.

I, RON ESSON, A BRITISH COLUMBIA LAND SURVEYOR,
CERTIFY THAT THE BUILDINGS SHOWN ON THIS STRATA PLAN
ARE WITHIN THE EXTERNAL BOUNDARIES OF THE LAND THAT
IS THE SUBJECT OF THE STRATA PLAN.

DATE: October 20, 2004

RJ Esson B.C.L.S.

I, RON ESSON, A BRITISH COLUMBIA LAND SURVEYOR,
OF SURREY, IN BRITISH COLUMBIA, CERTIFY THAT I WAS PRESENT AT
AND PERSONALLY SUPERINTENDED THE SURVEY REPRESENTED BY
THIS PLAN, AND THAT THE SURVEY AND PLAN ARE CORRECT.
THE FIELD SURVEY WAS COMPLETED ON THE 23rd DAY OF
October, 2004. THE PLAN WAS COMPLETED
AND CHECKED, AND THE CHECKLIST FILED UNDER 125027,
ON THE 28th DAY OF October, 2004.

RJ Esson B.C.L.S.

BUILDING FOUNDATION DETAILS (SOUTH)

STRATA PLAN BCS 1114 PHASE 1

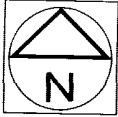

SCALE=1:500



THE CITY OF PORT MOODY AS HOLDER OF COVENANTS
RT3044477, BV408234, BV537381, BV537386, BV537403 AND BV537408
HEREBY CONSENTS TO THE FILING OF THIS STRATA PLAN.

[Signature]
AUTHORIZED SIGNATORY

[Signature]
AUTHORIZED SIGNATORY

WITNESS:
[Signature]

ADDRESS AND OCCUPATION OF WITNESS:
100 Newport Dr.
Port Moody, BC
Deputy City Clerk

APPROVED AS PHASE 1 OF A 2 PHASE STRATA PLAN
UNDER SECTION 224 OF THE STRATA PROPERTY ACT

DATE: November 22, 2004

[Signature]
APPROVING OFFICER FOR THE CITY OF PORT MOODY

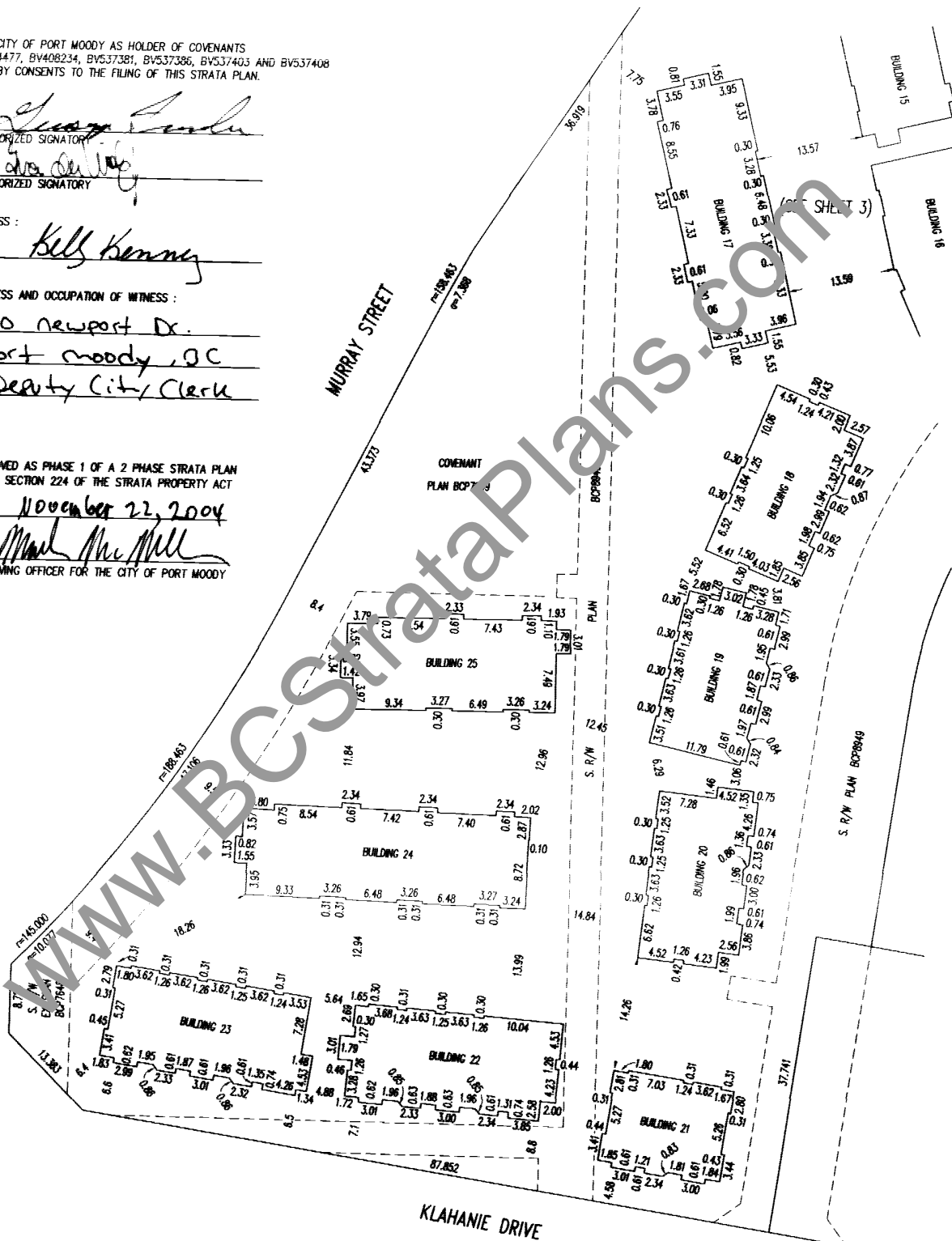

[Signature]
B.C.L.S.
DATED THIS 26th DAY OF October 2004

BUILDING FOUNDATION DETAILS (NORTH)

STRATA PLAN BCS 1114

PHASE 1

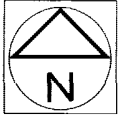

SCALE-1:500

0 5 10 20 30

ALL DISTANCES ARE IN METRES

MURRAY STREET

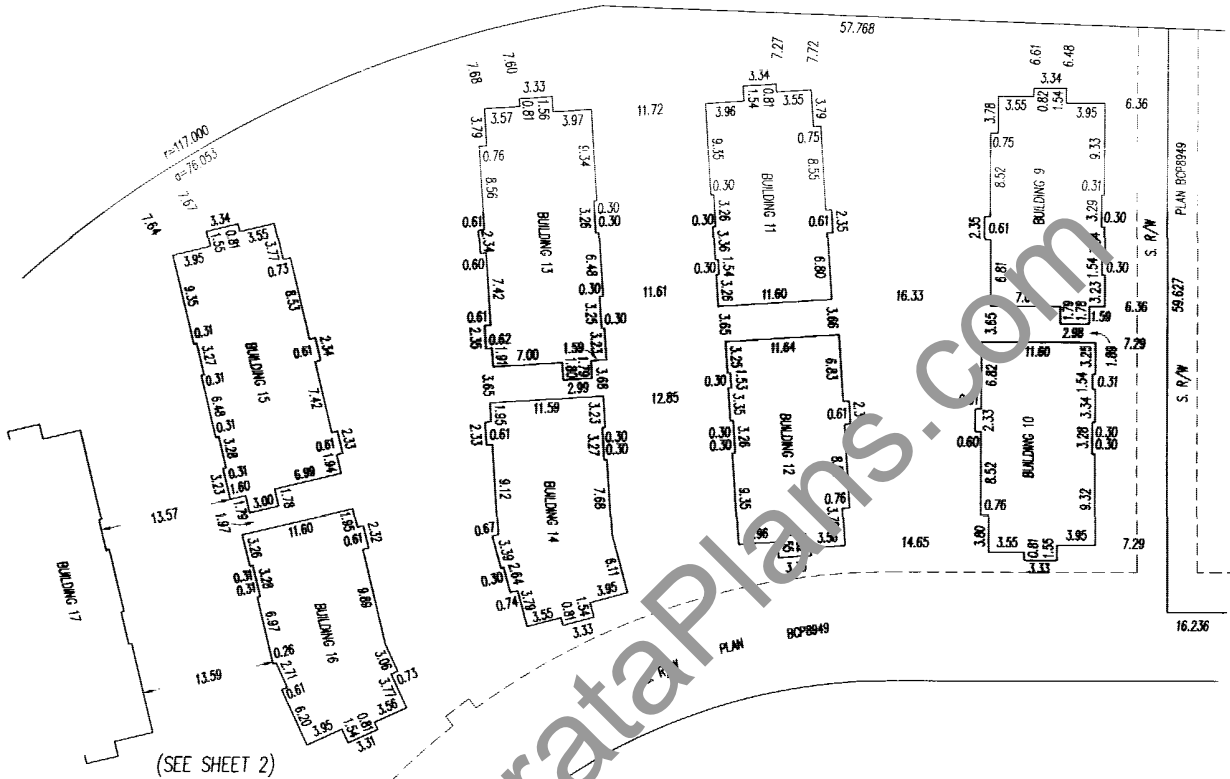

OWNER : POLYGON KLAHANE DEVELOPMENT LTD., INC. No.63 104

AUTHORIZED SIGNATORY RAULF SCHMIDT

AUTHORIZED SIGNATORY ROBERT RYAN

WITNESS :

TANYA MARIC

ADDRESS AND OCCUPATION OF WITNESS :

900-1330 WEST BROADWAY
VANCO VER BC V6H 4C2
Development Coordinator

MORTGAGEE : THE BANK OF NOVA SCOTIA

AUTHORIZED SIGNATORY PATRICK BRENNAN

AUTHORIZED SIGNATORY PETER BAYTER

WITNESS :

D. Atkar
D. Atkar

ADDRESS AND OCCUPATION OF WITNESS :

3400-650 W. Georgia St
Vancouver, BC
V6B 4N7 Banker

B.C.L.S

DATED THIS 28th DAY OF October 2004

FLOOR PLANS

STRATA PLAN BCS 1114

SCALE 1:200



ALL DISTANCES IN METRES

BUILDING 23

PHASE 1

GROUND FLOOR

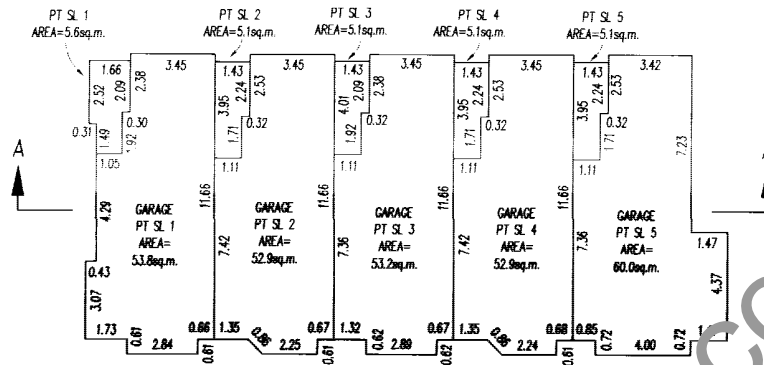
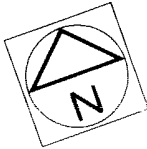

MAIN FLOOR

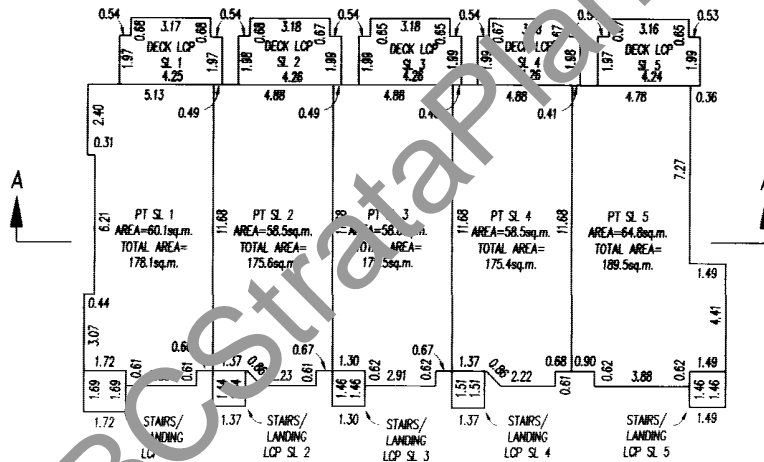

UPPER FLOOR

PERIMETER OF FLOOR BELOW

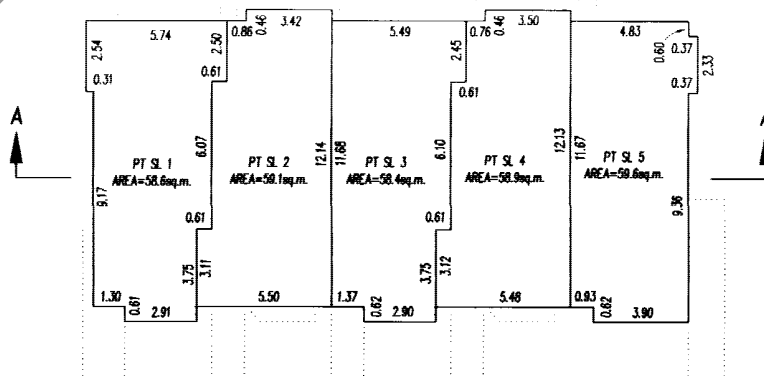

WWW.BestStrataPlans.com

RJE

DATED THIS 28th DAY OF October 2004

B.C.L.S.

FLOOR PLANS

STRATA PLAN BCS 1114 PHASE 1

SCALE 1:200



ALL DISTANCES IN METRES

BUILDING 22

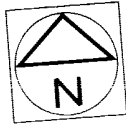

GROUND FLOOR

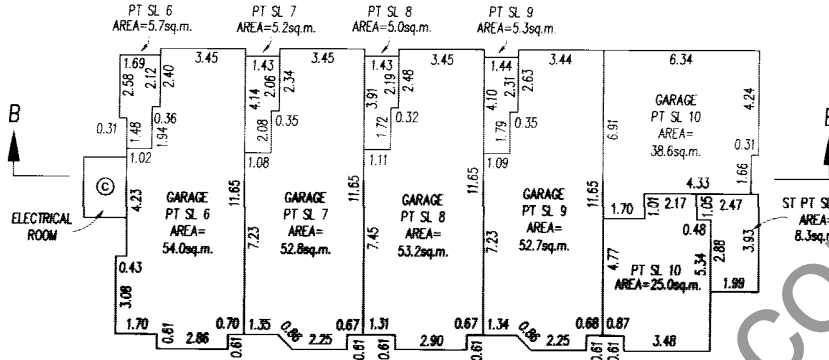

MAIN FLOOR

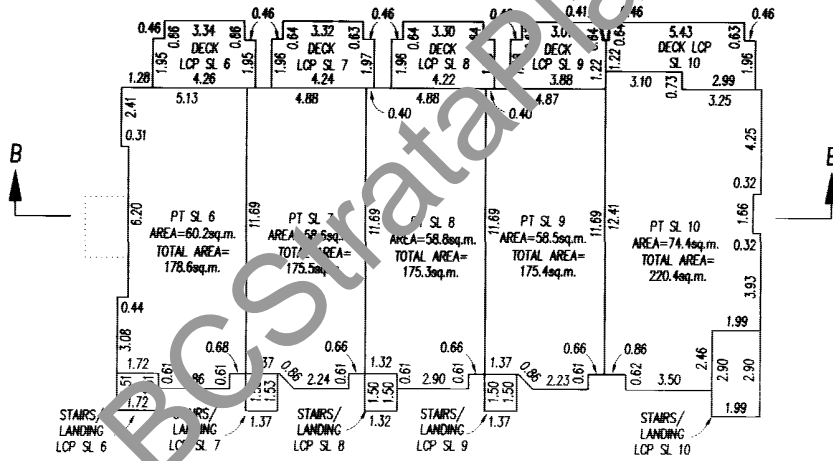

UPPER FLOOR

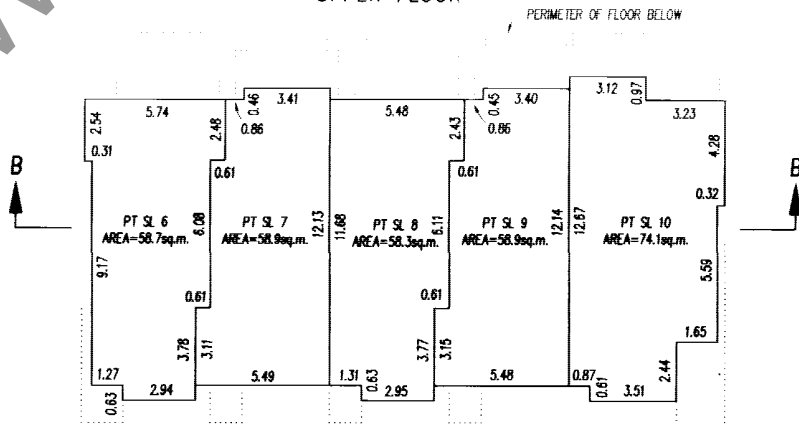

WWW.BCSstrataplans.com

Handwritten signature

DATED THIS 28th DAY OF October 2004 B.C.L.S.

FLOOR PLANS

BUILDING 21

STRATA PLAN BCS 1114 PHASE 1

SCALE 1:200



ALL DISTANCES IN METRES

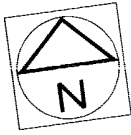

GROUND FLOOR

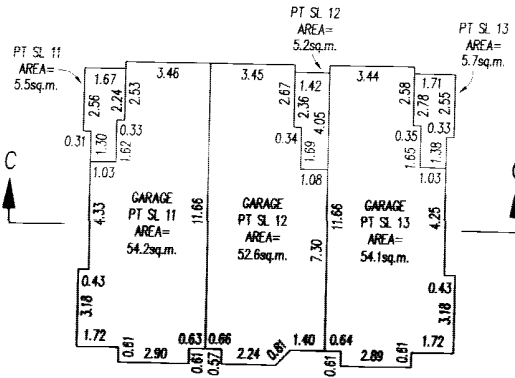

MAIN FLOOR

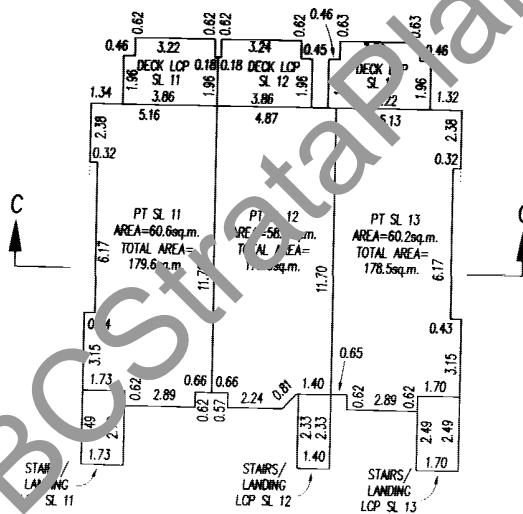

UPPER FLOOR

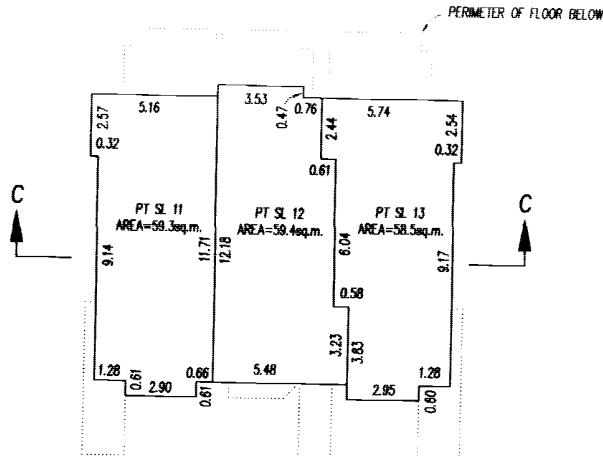

WWW.BCSstrataPlans.com

B.C.L.S.
 DATED THIS 28th DAY OF October 2004

FLOOR PLANS

STRATA PLAN BCS 1114 PHASE 1

SCALE 1:200



ALL DISTANCES IN METRES



BUILDING 24

GROUND FLOOR

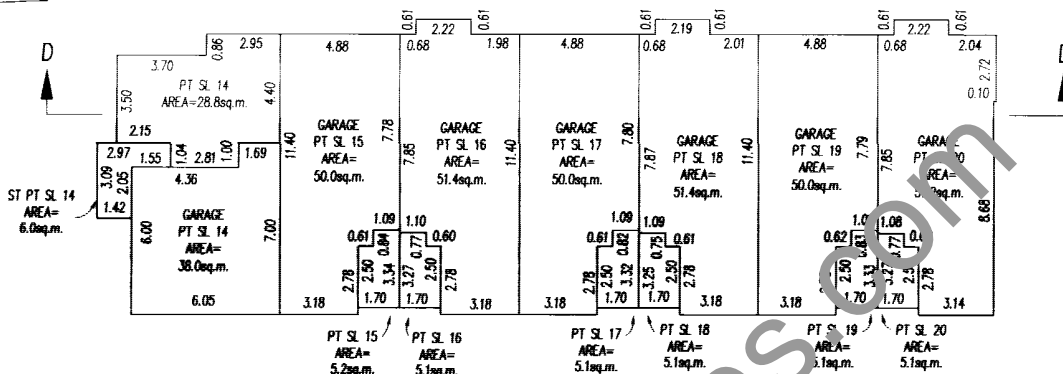

MAIN FLOOR

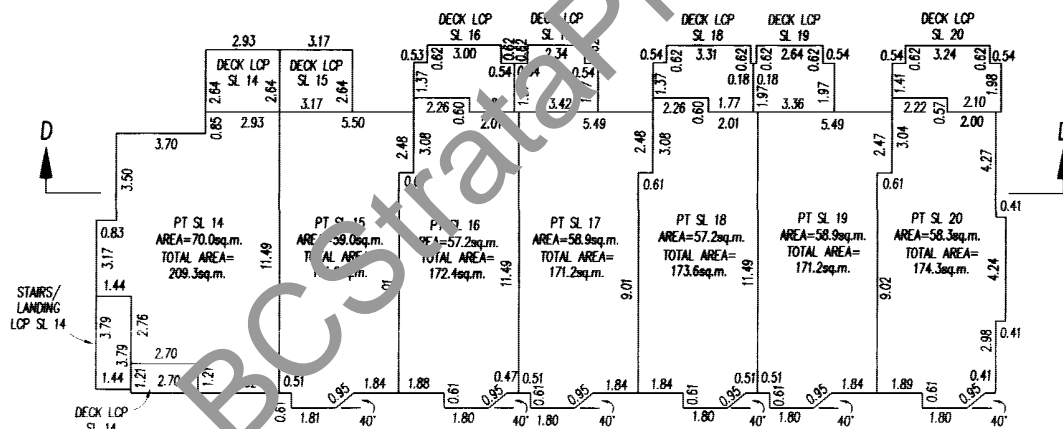

UPPER FLOOR

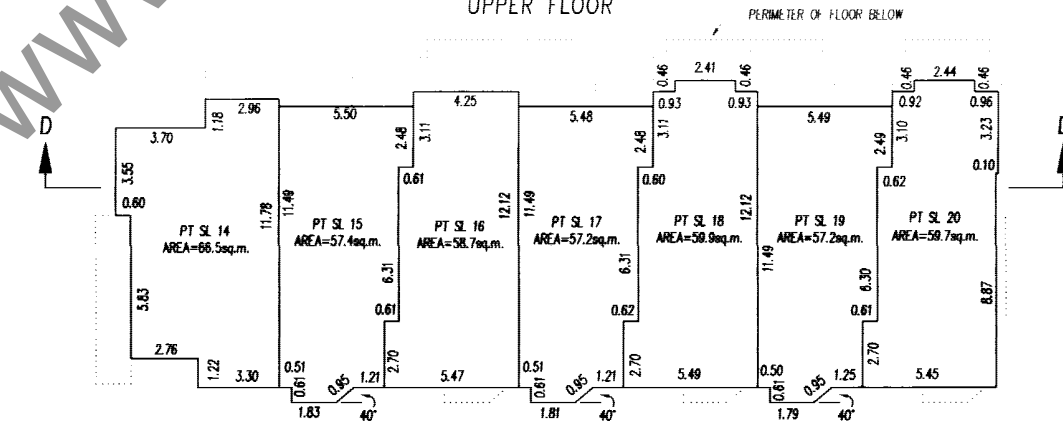

www.BCStrataPlans.com

B.C.L.S.
DATED THIS 28th DAY OF October 2004

FILED NWCBS1114 V69033 2006-10-27-14:28:51.179245

FLOOR PLANS

STRATA PLAN BCS 1114 PHASE 1

SCALE 1: 200

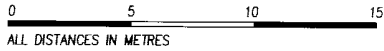

BUILDING 25

GROUND FLOOR

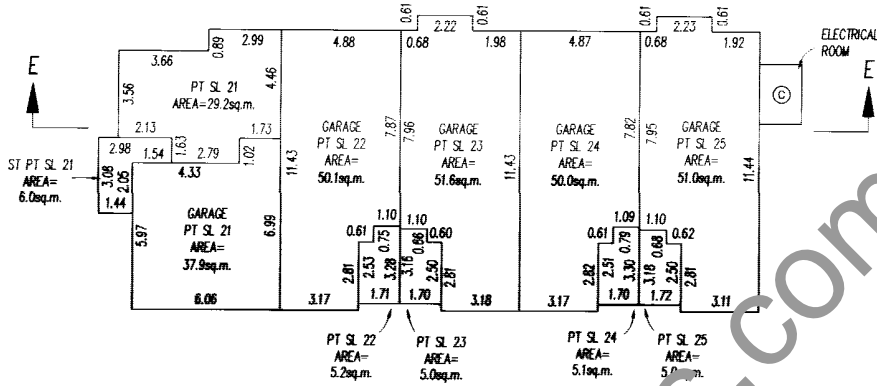
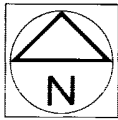

MAIN FLOOR

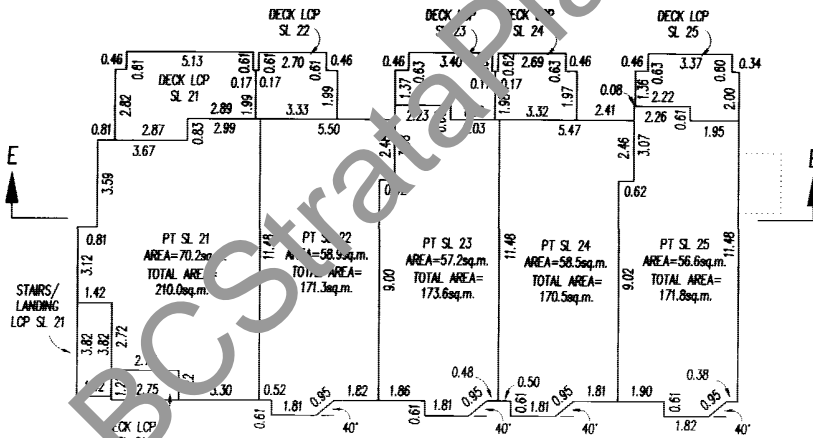

UPPER FLOOR

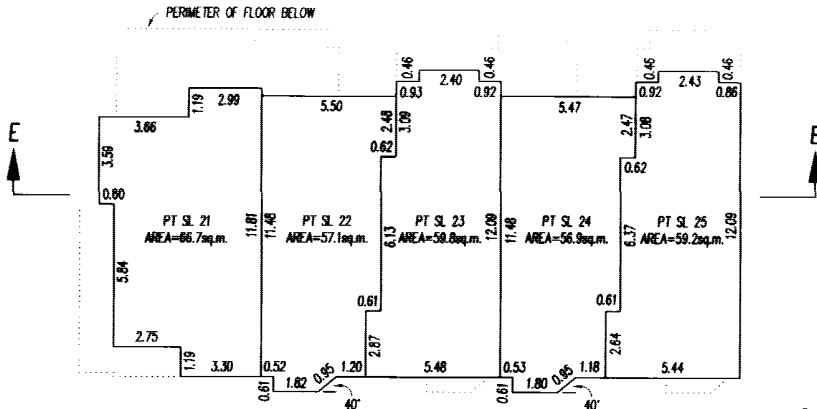

WWW.BCSstrataplans.com

BSE

B.C.L.S.

DATED THIS 28th DAY OF October 2004

FLOOR PLANS

STRATA PLAN BCS 1114 PHASE 1

SCALE 1:200



ALL DISTANCES IN METRES

BUILDING 20

GROUND FLOOR

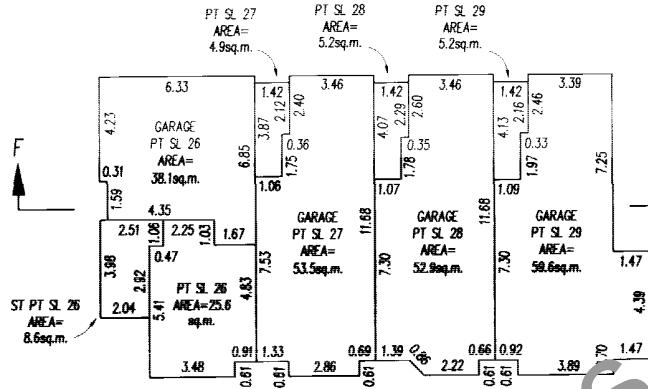
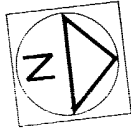

MAIN FLOOR

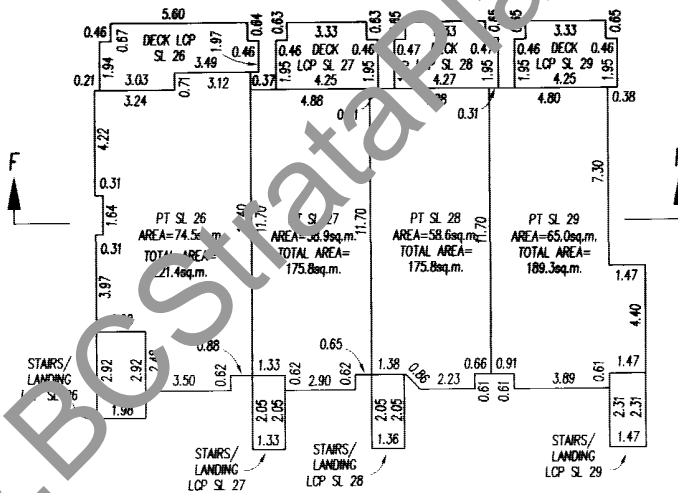

UPPER FLOOR

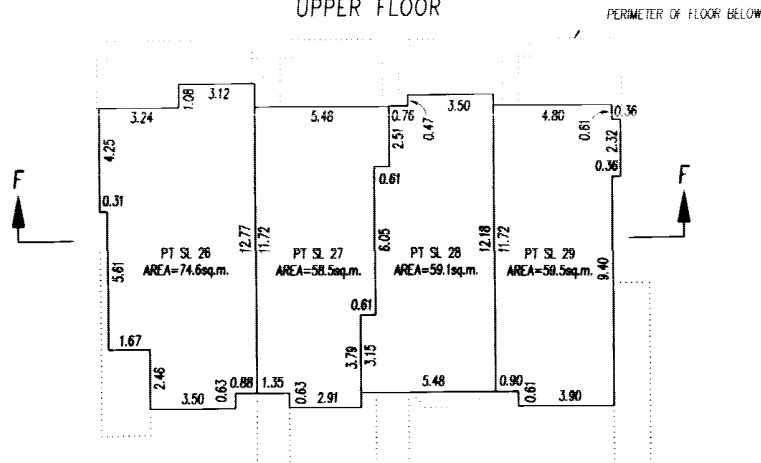

WWW.BCStrataPlans.com

RJE

B.C.L.S.

DATED THIS

20th DAY OF

October 2004

FLOOR PLANS

STRATA PLAN BCS 1114 PHASE 1

SCALE 1: 200



ALL DISTANCES IN METRES

BUILDING 19

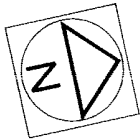

GROUND FLOOR

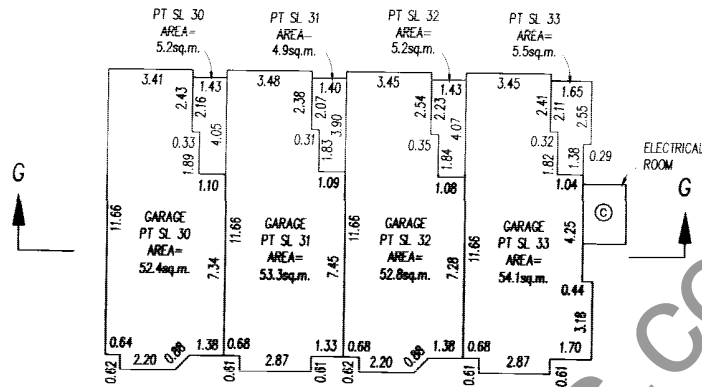

MAIN FLOOR

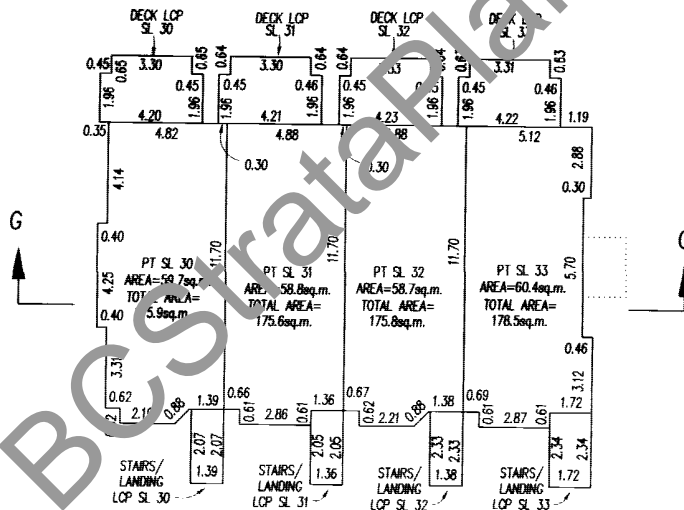

UPPER FLOOR

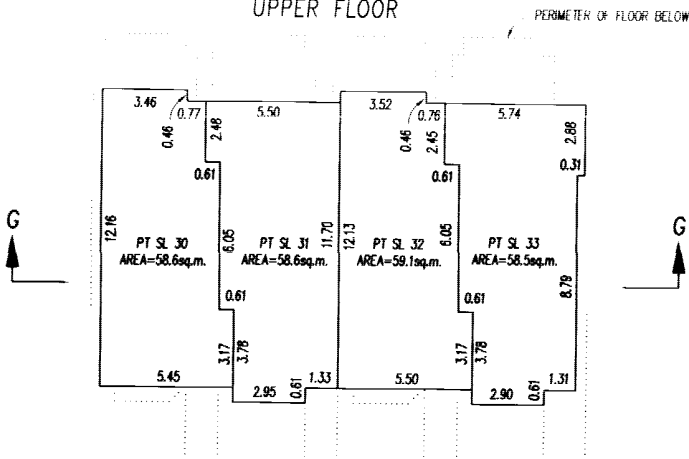

WWW.BCSstrataPlans.com

RJE

B.C.L.S.

DATED THIS 20th DAY OF October 2004

FLOOR PLANS

STRATA PLAN BCS 1114 PHASE 1

SCALE 1: 200



ALL DISTANCES IN METRES

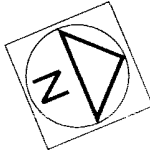

BUILDING 18

GROUND FLOOR

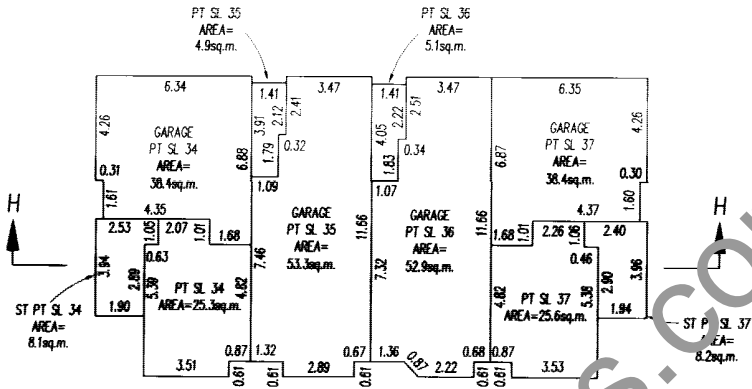

MAIN FLOOR

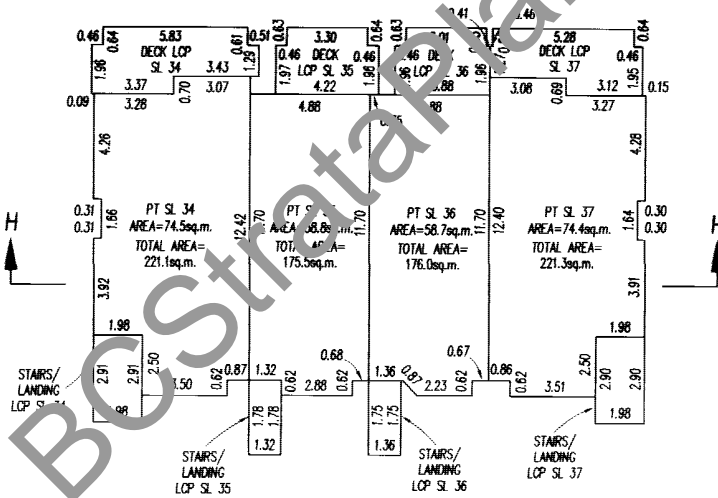

UPPER FLOOR

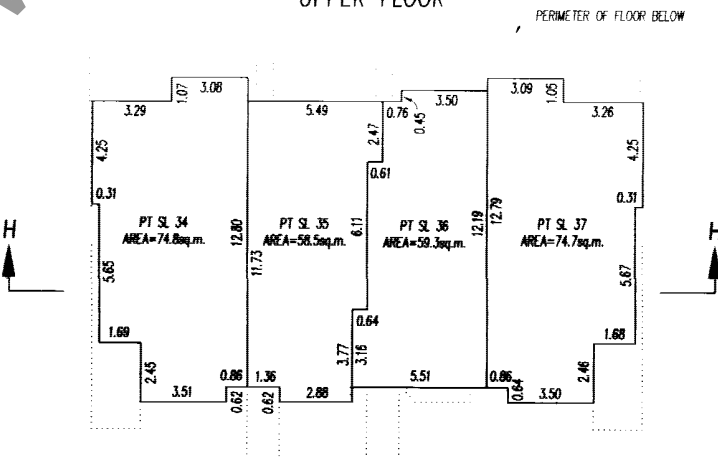

WWW.BCSstrataplans.com

GE

B.C.L.S.

DATED THIS 28th DAY OF October 2004

FLOOR PLANS

STRATA PLAN BCS 1114 PHASE 1

SCALE 1:200



ALL DISTANCES IN METRES

BUILDING 17

GROUND FLOOR

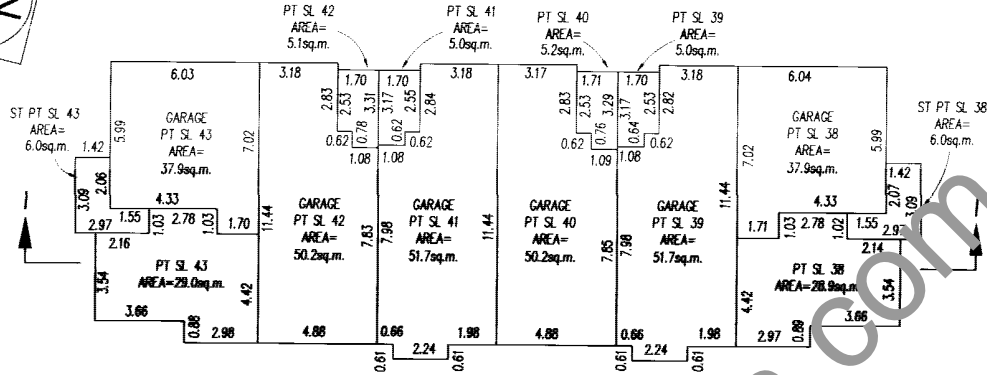
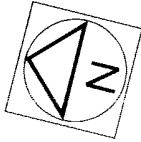

MAIN FLOOR

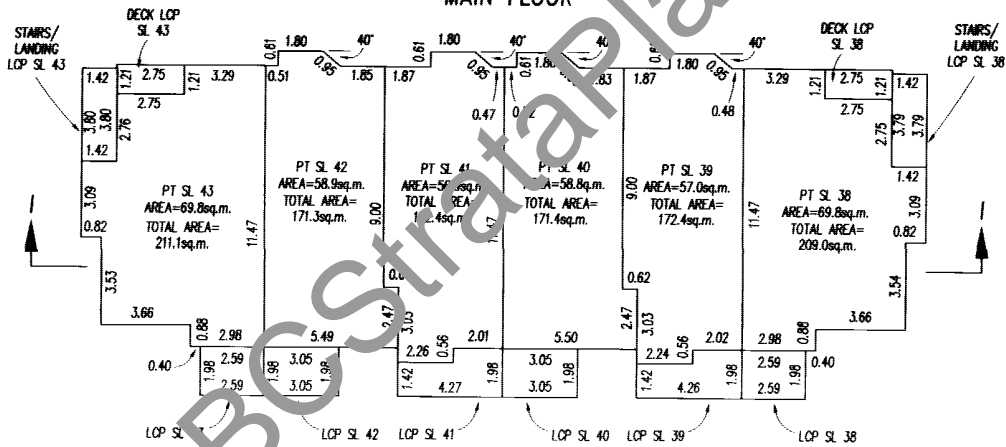

UPPER FLOOR

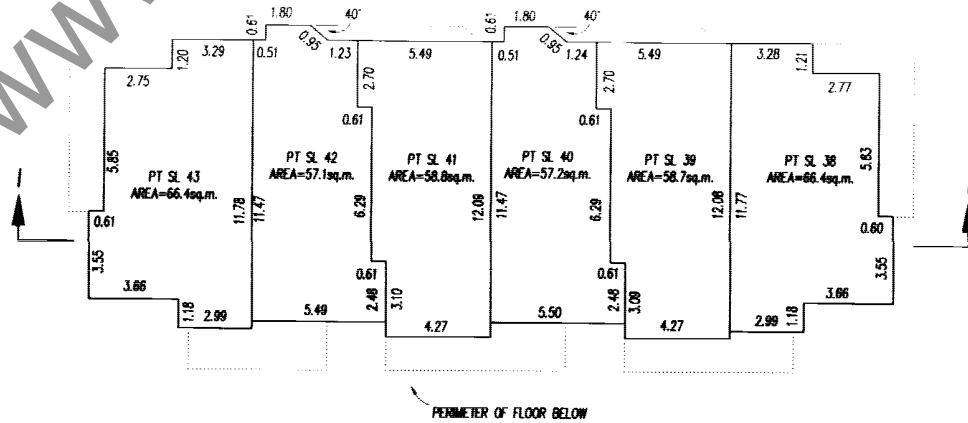

WWW.BCStrataPlans.com

B.C.L.S.
DATED THIS 28th DAY OF October 2004

FLOOR PLANS

STRATA PLAN BCS 1114 PHASE 1

SCALE 1: 200

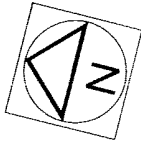
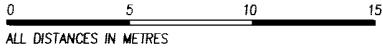

BUILDING 16

GROUND FLOOR

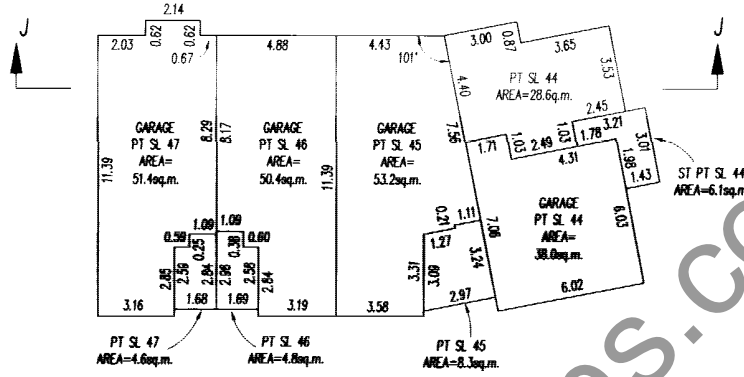

MAIN FLOOR

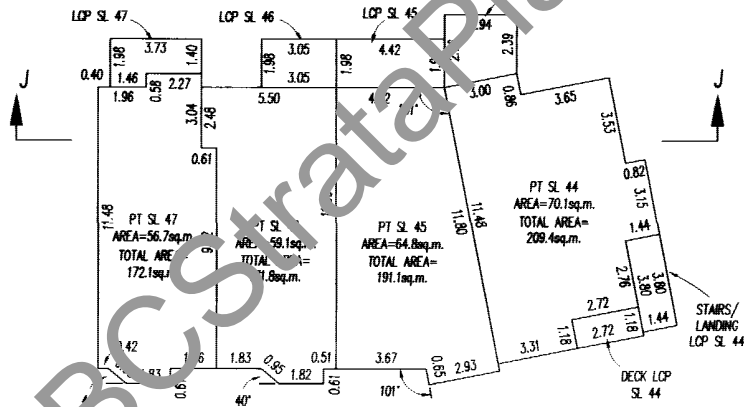

UPPER FLOOR

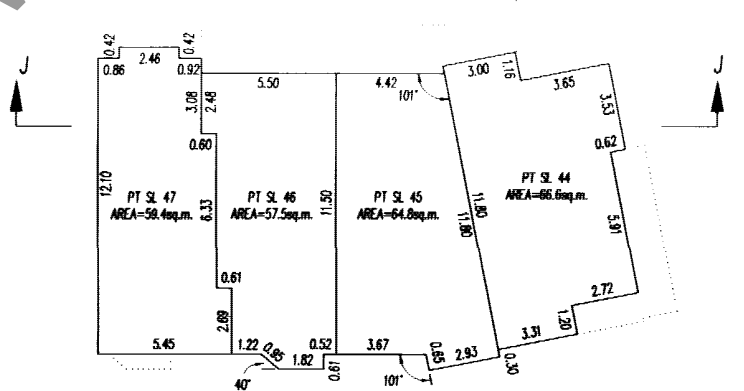

WWW.BCSstrataplans.com

 B.C.L.S.
 DATED THIS 28th DAY OF October 2004

FLOOR PLANS

STRATA PLAN BCS 1114 PHASE 1

SCALE 1: 200



ALL DISTANCES IN METRES

BUILDING 15

GROUND FLOOR

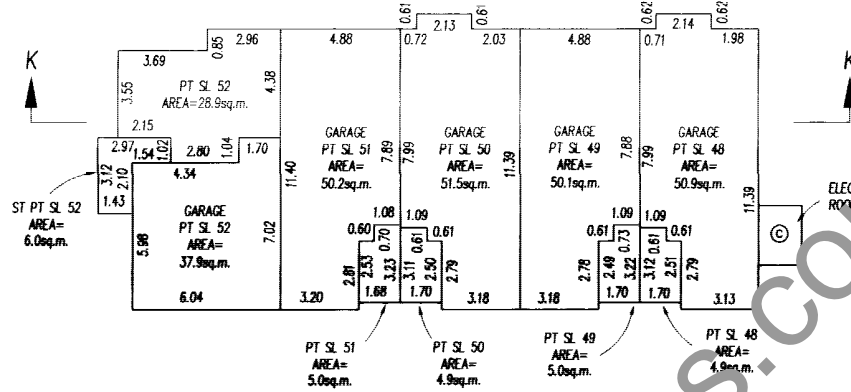
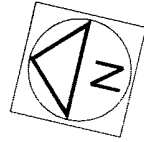

MAIN FLOOR

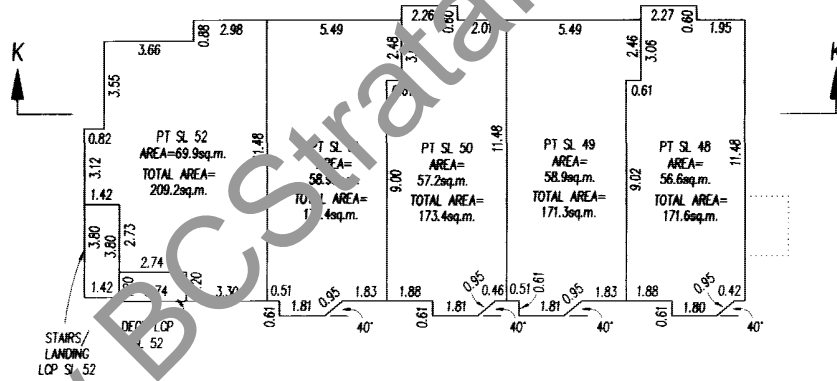

UPPER FLOOR

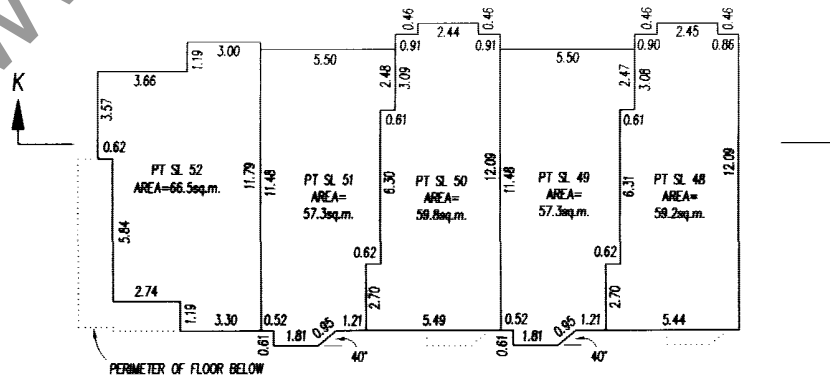

WWW.BCStrataPlans.com

GE

DATED THIS

28th

DAY OF

October

B.C.L.S.

2004

FLOOR PLANS

STRATA PLAN BCS 1114 PHASE 1

SCALE 1: 200



ALL DISTANCES IN METRES

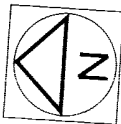

BUILDING 14

GROUND FLOOR

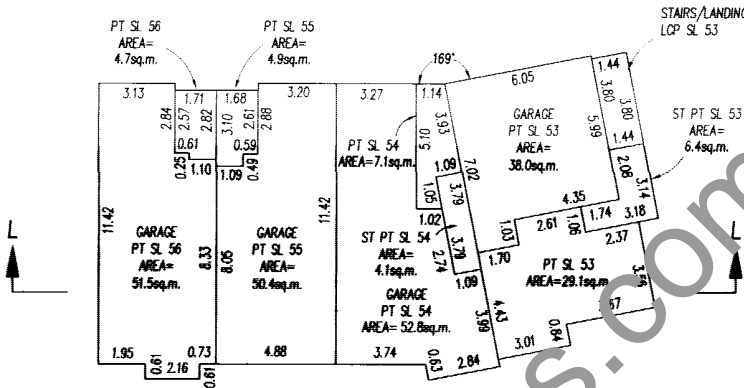

MAIN FLOOR

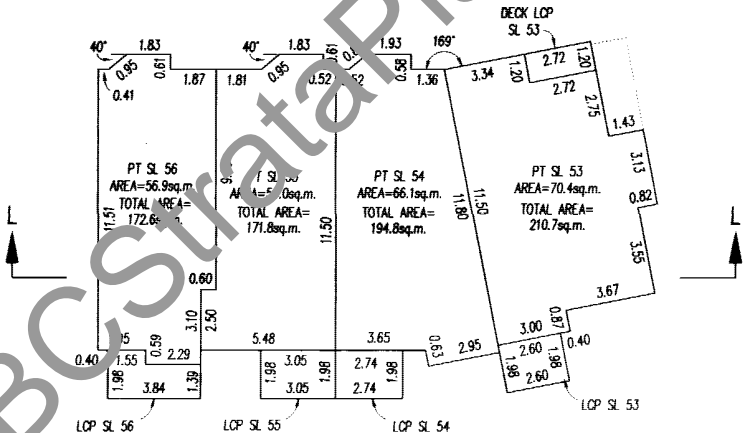

UPPER FLOOR

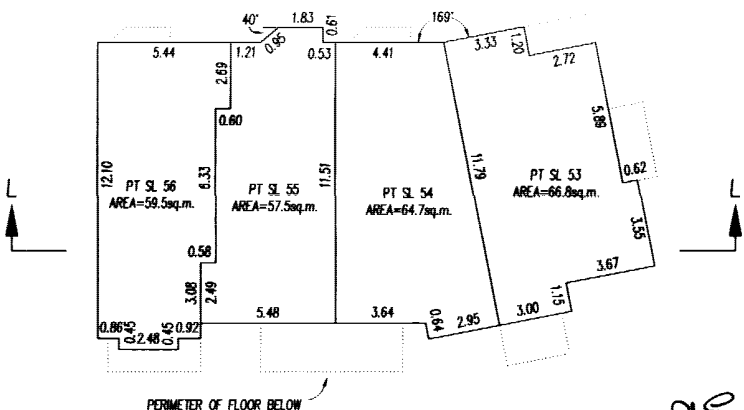

WWW.BCStrataPlans.com

B.C.L.S.
 DATED THIS 28th DAY OF October 2004

FLOOR PLANS

STRATA PLAN BCS 1114 PHASE 1

SCALE 1:200

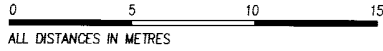

BUILDING 13

GROUND FLOOR

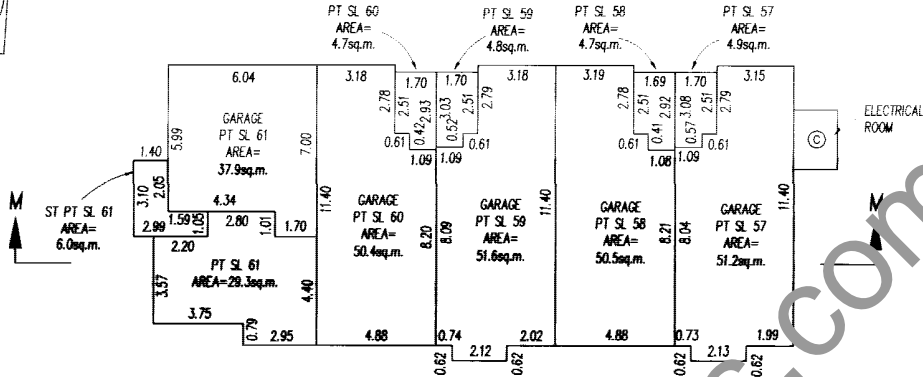
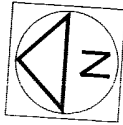

MAIN FLOOR

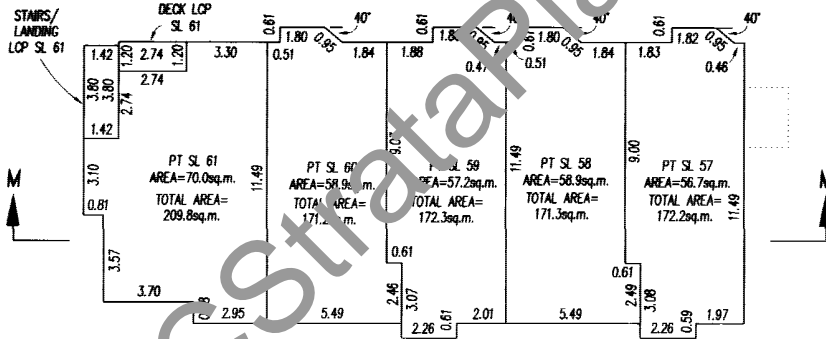

UPPER FLOOR

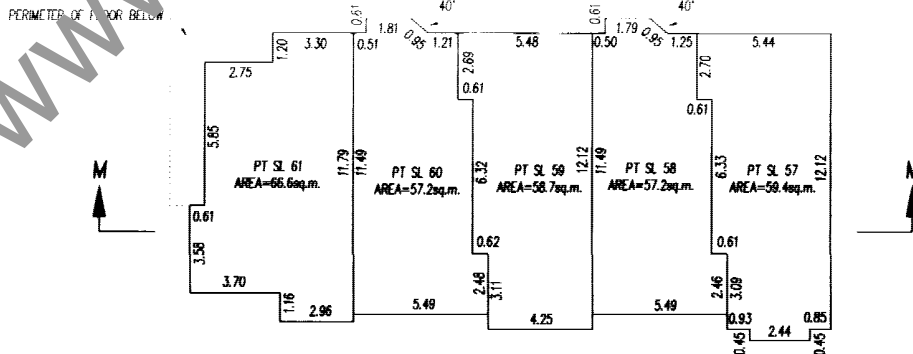

WWW.BCStrataPlans.com

RJE

DATED THIS 28th DAY OF October 2004 B.C.L.S.

FLOOR PLANS

STRATA PLAN BCS 1114 PHASE 1

SCALE 1: 200



ALL DISTANCES IN METRES

BUILDING 12

GROUND FLOOR

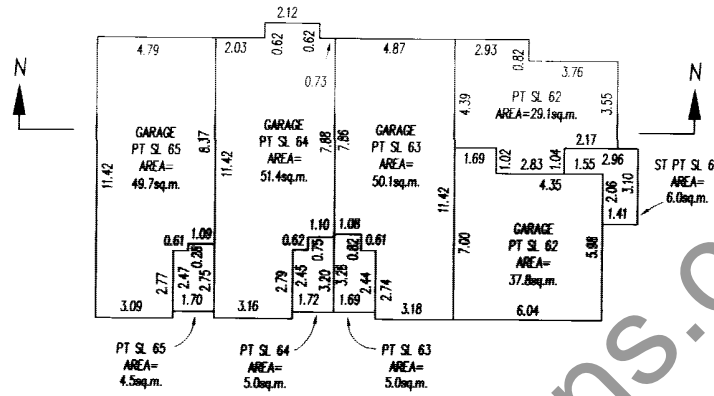
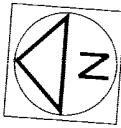

MAIN FLOOR

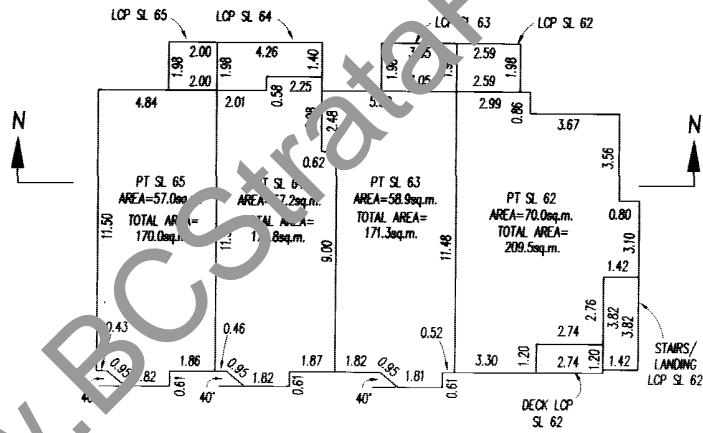

UPPER FLOOR

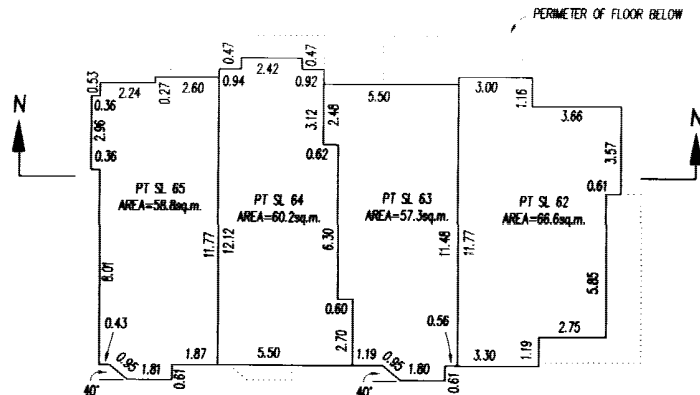

WWW.BCSstrataPlans.com

BJE

B.C.L.S.

DATED THIS 28th DAY OF October 2004

FLOOR PLANS

STRATA PLAN BCS 1114 PHASE 1

SCALE 1:200



ALL DISTANCES IN METRES

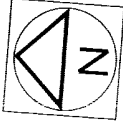

BUILDING 11

GROUND FLOOR

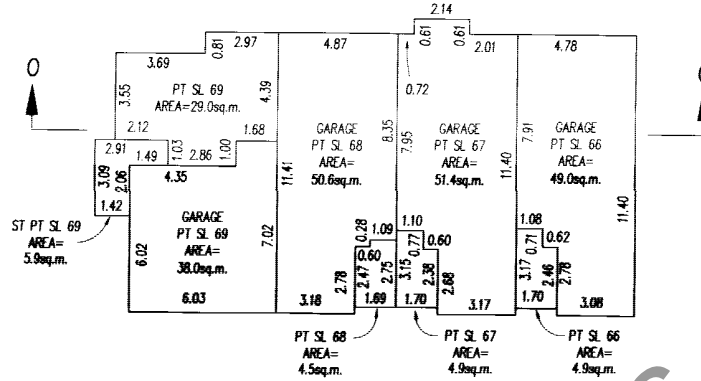

MAIN FLOOR

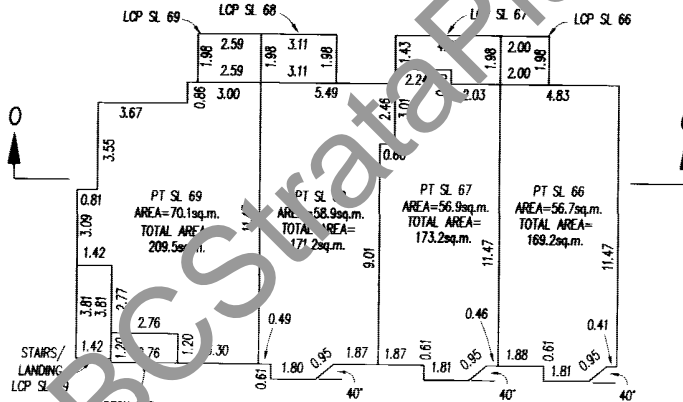

UPPER FLOOR

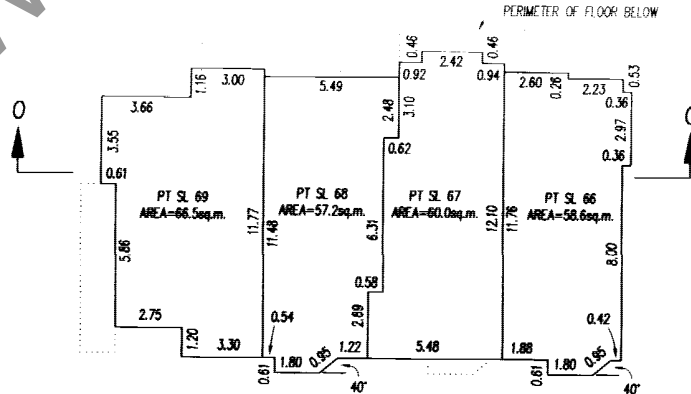

WWW.BCSstrataPlans.com

B.C.L.S.
DATED THS 28th DAY OF October 2004

RJE

FLOOR PLANS

STRATA PLAN BCS 1114 PHASE 1

SCALE 1: 200

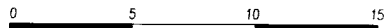

ALL DISTANCES IN METRES

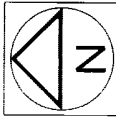

BUILDING 10

GROUND FLOOR

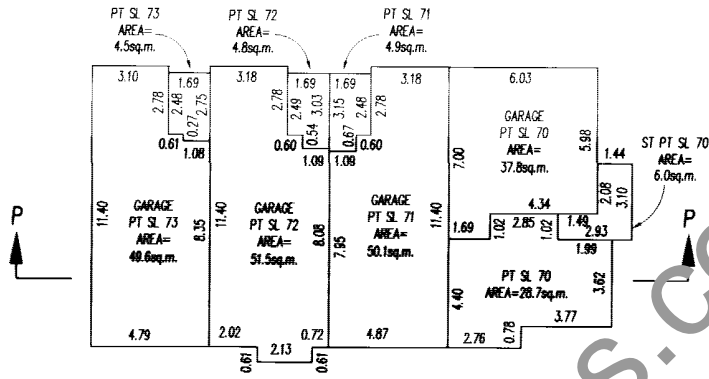

MAIN FLOOR

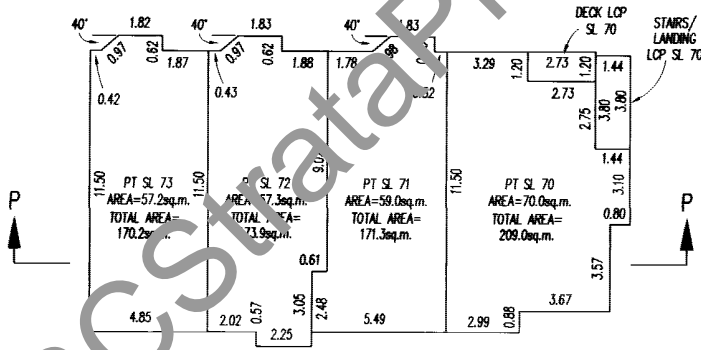

UPPER FLOOR

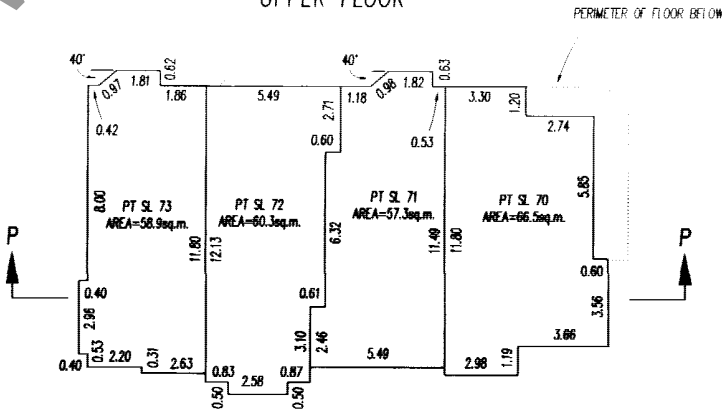

WWW.BCStrataPlans.com

gje

DATED THIS 28th DAY OF October 2004

B.C.L.S.

FLOOR PLANS

STRATA PLAN BCS 1114 PHASE 1

SCALE 1:200



ALL DISTANCES IN METRES

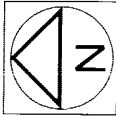

BUILDING 9

GROUND FLOOR

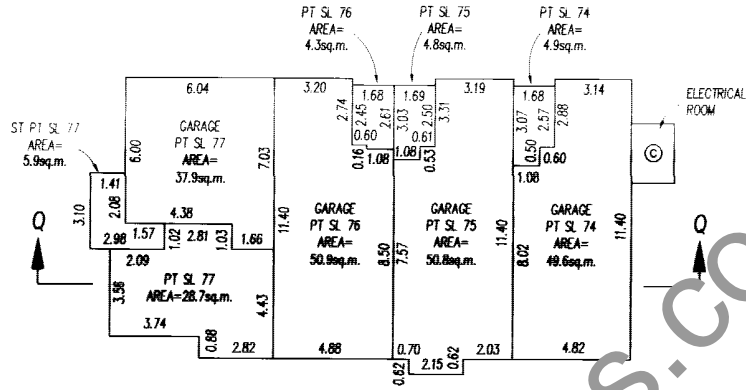

MAIN FLOOR

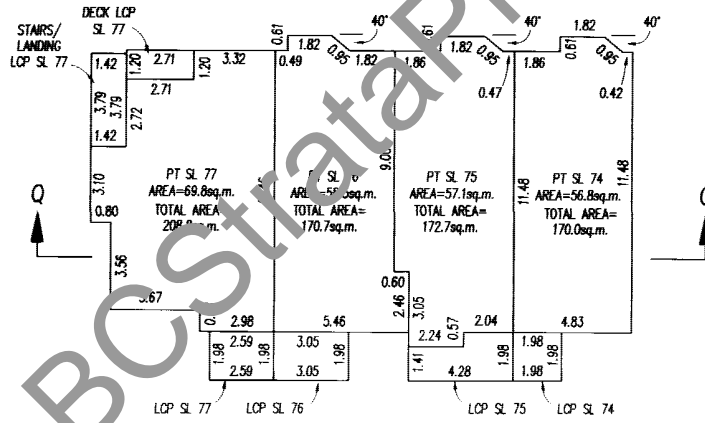

UPPER FLOOR

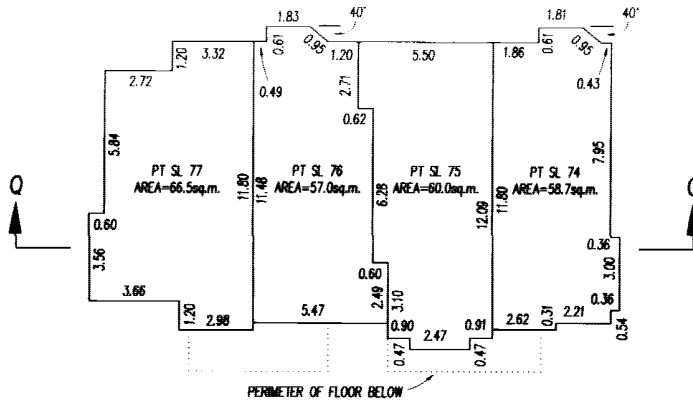

WWW.BCStrataPlans.com

ge

B.C.L.S.

DATED THIS 28th DAY OF October 2004

SECTIONS

SCALE-1:200

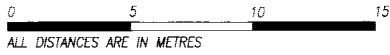

STRATA PLAN BCS 1114
PHASE 1

BUILDING 23

PT SL 1	PT SL 2	PT SL 3	PT SL 4	PT SL 5	UPPER FLOOR
PT SL 1	PT SL 2	PT SL 3	PT SL 4	PT SL 5	MAIN FLOOR
GARAGE PT SL 1	GARAGE PT SL 2	GARAGE PT SL 3	GARAGE PT SL 4	GARAGE PT SL 5	GROUND FLOOR GROUND LEVEL

SECTION A-A

BUILDING 22

	PT SL 6	PT SL 7	PT SL 8	PT SL 9	PT SL 10	UPPER FLOOR
	PT SL 6	PT SL 7	PT SL 8	PT SL 9	PT SL 10	MAIN FLOOR
ELECTRICAL ROOM	GARAGE PT SL 6	GARAGE PT SL 7	GARAGE PT SL 8	GARAGE PT SL 9	GARAGE PT SL 10	GROUND FLOOR GROUND LEVEL

SECTION B-B

BUILDING 21

PT SL 11	PT SL 12	PT SL 13	UPPER FLOOR
PT SL 11	PT SL 12	PT SL 13	MAIN FLOOR
GARAGE PT SL 11	GARAGE PT SL 12	GARAGE PT SL 13	GROUND FLOOR GROUND LEVEL

SECTION C-C

BUILDING 24

PT SL 14	PT SL 15	PT SL 16	PT SL 17	PT SL 18	PT SL 19	PT SL 20	UPPER FLOOR
PT SL 14	PT SL 15	PT SL 16	PT SL 17	PT SL 18	PT SL 19	PT SL 20	MAIN FLOOR
PT SL 14	GARAGE PT SL 15	GARAGE PT SL 16	GARAGE PT SL 17	GARAGE PT SL 18	GARAGE PT SL 19	GARAGE PT SL 20	GROUND FLOOR GROUND LEVEL

SECTION D-D

BUILDING 25

PT SL 21	PT SL 22	PT SL 23	PT SL 24	PT SL 25	UPPER FLOOR
PT SL 21	PT SL 22	PT SL 23	PT SL 24	PT SL 25	MAIN FLOOR
PT SL 21	GARAGE PT SL 22	GARAGE PT SL 23	GARAGE PT SL 24	GARAGE PT SL 25	GROUND FLOOR GROUND LEVEL

SECTION E-E

JE

B.C.L.S

DATED THIS 28th DAY OF October 2004

SECTIONS

STRATA PLAN BCS 1114

SCALE-1:200

PHASE 1



BUILDING 20

PT SL 26	PT SL 27	PT SL 28	PT SL 29	UPPER FLOOR
PT SL 26	PT SL 27	PT SL 28	PT SL 29	MAIN FLOOR
GARAGE PT SL 26	GARAGE PT SL 27	GARAGE PT SL 28	GARAGE PT SL 29	GROUND FLOOR
				GROUND LEVEL

SECTION F-F

BUILDING 19

PT SL 30	PT SL 31	PT SL 32	PT SL 33	UPPER FLOOR
PT SL 30	PT SL 31	PT SL 32	PT SL 33	MAIN FLOOR
GARAGE PT SL 30	GARAGE PT SL 31	GARAGE PT SL 32	GARAGE PT SL 33	GROUND FLOOR
				GROUND LEVEL

SECTION C-G

BUILDING 18

PT SL 34	PT SL 35	PT SL 36	PT SL 37	UPPER FLOOR
PT SL 34	PT SL 35	PT SL 36	PT SL 37	MAIN FLOOR
PT SL 34	GARAGE PT SL 35	GARAGE PT SL 36	PT SL 37	GROUND FLOOR
				GROUND LEVEL

SECTION H-H

BUILDING 17

PT SL 43	PT SL 42	PT SL 41	PT SL 40	PT SL 39	PT SL 38	UPPER FLOOR
PT SL 43	PT SL 42	PT SL 41	PT SL 40	PT SL 39	PT SL 38	MAIN FLOOR
PT SL 43	GARAGE PT SL 42	GARAGE PT SL 41	GARAGE PT SL 40	GARAGE PT SL 39	PT SL 38	GROUND FLOOR
						GROUND LEVEL

SECTION I-I

WWW.BCStrataPlans.com

ge

B.C.L.S

DATED THIS 28th DAY OF October 2004

SECTIONS

STRATA PLAN BCS 1114

SCALE-1:200

PHASE 1

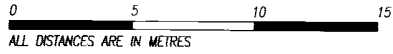

BUILDING 16

PT SL 47	PT SL 46	PT SL 45	PT SL 44	UPPER FLOOR
PT SL 47	PT SL 46	PT SL 45	PT SL 44	MAIN FLOOR
GARAGE PT SL 47	GARAGE PT SL 46	GARAGE PT SL 45	PT SL 44	GROUND FLOOR
				GROUND LEVEL

SECTION J-J

BUILDING 15

PT SL 52	PT SL 51	PT SL 50	PT SL 49	PT SL 48	UPPER FLOOR
PT SL 52	PT SL 51	PT SL 50	PT SL 49	PT SL 48	MAIN FLOOR
PT SL 52	GARAGE PT SL 51	GARAGE PT SL 50	GARAGE PT SL 49	GARAGE PT SL 48	GROUND FLOOR
					GROUND LEVEL

SECTION K-K

BUILDING 14

PT SL 56	PT SL 55	PT SL 54	PT SL 53	UPPER FLOOR
PT SL 56	PT SL 55	PT SL 54	PT SL 53	MAIN FLOOR
GARAGE PT SL 56	GARAGE PT SL 55	GARAGE PT SL 54	PT SL 53	GROUND FLOOR
				GROUND LEVEL

SECTION L-L

BUILDING 13

PT SL 61	PT SL 60	PT SL 59	PT SL 58	PT SL 57	UPPER FLOOR
PT SL 61	PT SL 60	PT SL 59	PT SL 58	PT SL 57	MAIN FLOOR
PT SL 61	GARAGE PT SL 60	GARAGE PT SL 59	GARAGE PT SL 58	GARAGE PT SL 57	GROUND FLOOR
					GROUND LEVEL

SECTION M-M

WWW.BCStrataPlans.com

B.C.L.S

DATED THIS 20th DAY OF October 2004

SECTIONS

SCALE-1:200



STRATA PLAN BCS 1114
PHASE 1

BUILDING 12

PT SL 65	PT SL 64	PT SL 63	PT SL 62	UPPER FLOOR
PT SL 65	PT SL 64	PT SL 63	PT SL 62	MAIN FLOOR
GARAGE PT SL 65	GARAGE PT SL 64	GARAGE PT SL 63	PT SL 62	GROUND FLOOR GROUND LEVEL

SECTION N-N

BUILDING 11

PT SL 69	PT SL 68	PT SL 67	PT SL 66	UPPER FLOOR
PT SL 69	PT SL 68	PT SL 67	PT SL 66	MAIN FLOOR
PT SL 69	GARAGE PT SL 68	GARAGE PT SL 67	GARAGE PT SL 66	GROUND FLOOR GROUND LEVEL

SECTION O-O

BUILDING 10

PT SL 73	PT SL 72	PT SL 71	PT SL 70	UPPER FLOOR
PT SL 73	PT SL 72	PT SL 71	PT SL 70	MAIN FLOOR
GARAGE PT SL 73	GARAGE PT SL 72	GARAGE PT SL 71	PT SL 70	GROUND FLOOR GROUND LEVEL

SECTION P-P

BUILDING 9

PT SL 77	PT SL 76	PT SL 75	PT SL 74	UPPER FLOOR
PT SL 77	PT SL 76	PT SL 75	PT SL 74	MAIN FLOOR
PT SL 77	GARAGE PT SL 76	GARAGE PT SL 75	GARAGE PT SL 74	GROUND FLOOR GROUND LEVEL

SECTION Q-Q

WWW.BCStrataPlans.com

gje

B.C.L.S

DATED THIS 28th DAY OF October 2004

PHASED STRATA PLAN OF LOT 1 EXCEPT: PHASE ONE STRATA PLAN BCS1114; DISTRICT LOTS 190 AND 235, GROUP 1, NEW WESTMINSTER DISTRICT, PLAN BCP8948

STRATA PLAN BCS1114 PHASE 2

DEPOSITED AND REGISTERED IN THE LAND TITLE OFFICE AT NEW WESTMINSTER, B.C. JUNE 1, 2005

J. MacDonald / 168
REGISTRAR
Bx 448999 - Bx 449048

SCALE-1:1000 THIS PLAN LIES WITHIN THE GREATER VANCOUVER REGIONAL DISTRICT



CIVIC ADDRESS

100 KLAHANIE DRIVE
CITY OF PORT MOODY

INTEGRATED SURVEY AREA
No.35 (CITY OF PORT MOODY) NAD83 (CSRS)
B.C.G.S. 92C 026

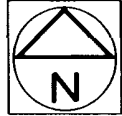

REM. PCL. "A"
R.P. 55526

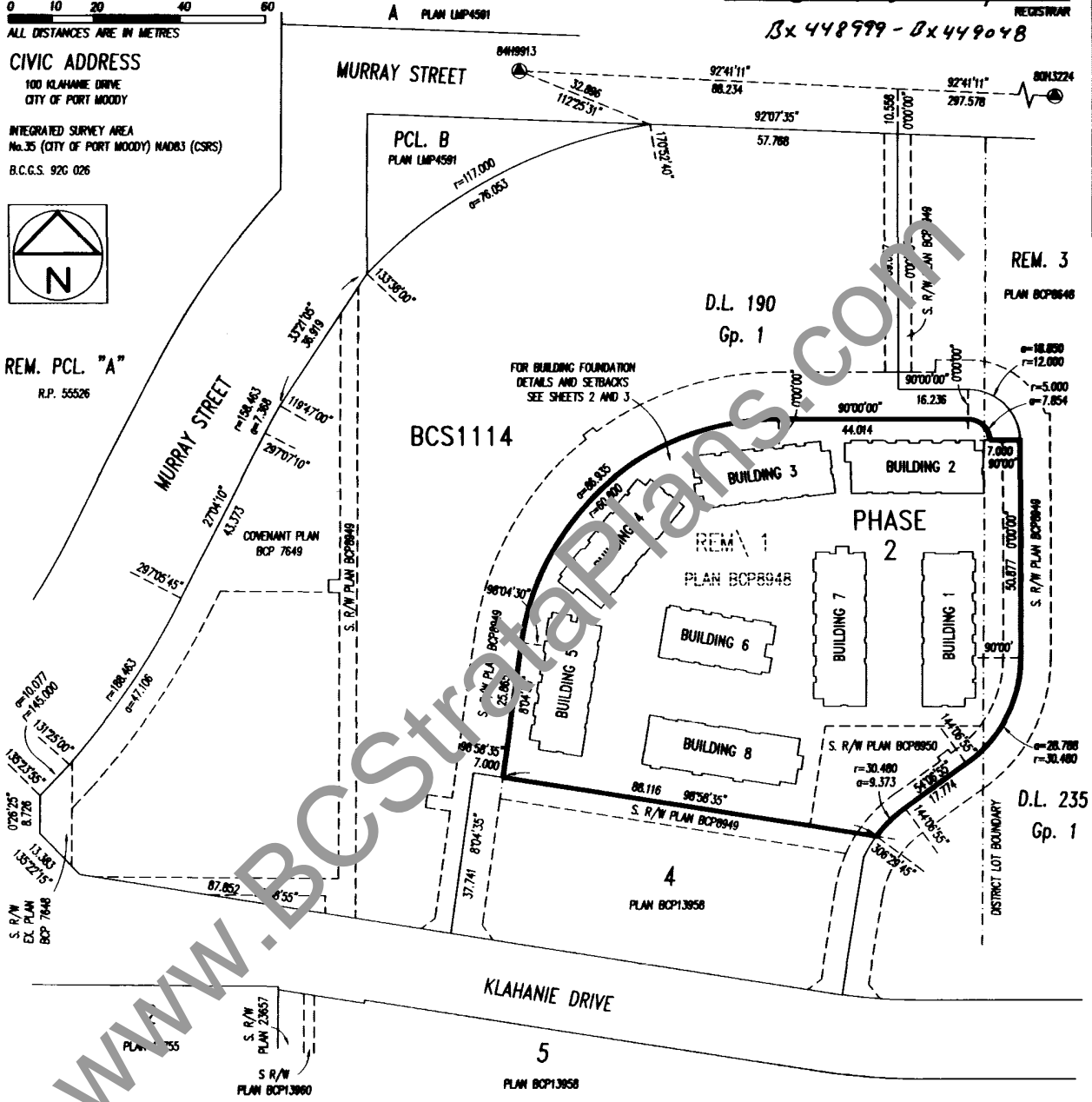

STRATA LOT ANGLES ARE 45° OR 90° UNLESS OTHERWISE NOTED.
THIS PLAN SHOWS GROUND LEVEL MEASURED DISTANCES. PRIOR TO COMPUTATION OF UTM COORDINATES, MULTIPLY BY THE COMBINED FACTOR 0.999603267.

GRID BEARINGS ARE DERIVED FROM OLD CONTROL MONUMENTS 84H9913 AND 80H3224

LEGEND

LCP	INDICATES	LIMITED COMMON PROPERTY
sq.m.	•	SQUARE METRES
SL	•	STRATA LOT
PT	•	PART
⊙	•	COMMON PROPERTY
⊙	•	OLD CONTROL MONUMENT FOUND
ST	•	STORAGE

I, RON ESSON, A BRITISH COLUMBIA LAND SURVEYOR, CERTIFY THAT THE BUILDINGS INCLUDED IN THE STRATA PLAN HAVE NOT, AS OF May 5, 2005, BEEN PREVIOUSLY OCCUPIED

RJ Esso B.C.L.S.

* SECTION 241 (2) PROVIDES THAT THE ENDORSEMENT MUST BE DATED NOT MORE THAN 180 DAYS BEFORE THE DATE THE STRATA PLAN IS RENDERED FOR DEPOSIT.

I, RON ESSON, A BRITISH COLUMBIA LAND SURVEYOR, CERTIFY THAT THE BUILDINGS SHOWN ON THIS STRATA PLAN ARE WITHIN THE EXTERNAL BOUNDARIES OF THE LAND THAT IS THE SUBJECT OF THE STRATA PLAN.

DATE: May 5, 2005

RJ Esso B.C.L.S.

I, RON ESSON, A BRITISH COLUMBIA LAND SURVEYOR, OF SURREY, IN BRITISH COLUMBIA, CERTIFY THAT I WAS PRESENT AT AND PERSONALLY SUPERVISED THE SURVEY REPRESENTED BY THIS PLAN, AND THAT THE SURVEY AND PLAN ARE CORRECT.

THE FIELD SURVEY WAS COMPLETED ON THE 5th DAY OF May, 2005. THE PLAN WAS COMPLETED AND CHECKED, AND THE CHECKLIST FILED UNDER 30913, ON THE 5th DAY OF May, 2005.

RJ Esso B.C.L.S.

WWW.BCStrataPlans.com

FILED WBCS1114 V69033 2006-10-27-14:28:51.179245

BUILDING FOUNDATION DETAILS (WEST)

STRATA PLAN BCS1114

PHASE 2



SCALE-1:500

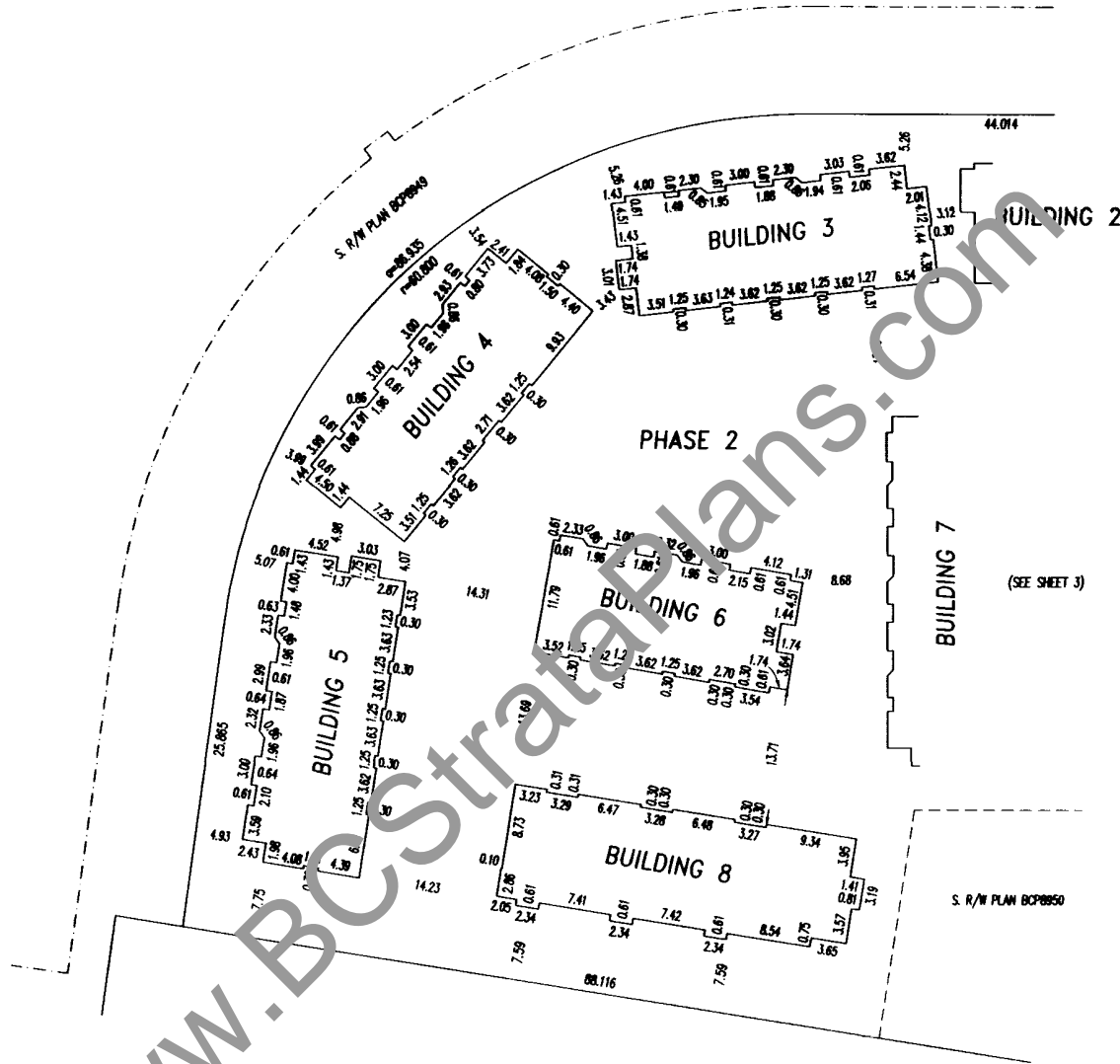

THE CITY OF PORT MOODY AS HOLDER OF COVENANTS
BT304477, BV537381, BV537386, BV537403 AND BV537408
HEREBY CONSENTS TO THE FILING OF THIS STRATA PLAN.

Giuseppe Trasolini
AUTHORIZED SIGNATORY Giuseppe Trasolini, Mayor

Colleen Rohde
AUTHORIZED SIGNATORY Colleen Rohde, City Clerk

WITNESS:
Kelly Keamey
Kelly Keamey

ADDRESS AND OCCUPATION OF WITNESS:
100 Newport Dr.
Port Moody, BC
Deputy City Clerk

APPROVED AS PHASE 2 OF A 2 PHASE STRATA PLAN
UNDER SECTION 224 OF THE STRATA PROPERTY ACT
DATE: May 27, 2005
[Signature]
APPROVING OFFICER FOR THE CITY OF PORT MOODY

[Signature]
B.C.L.S.
DATED THIS 5th DAY OF May 2005

BUILDING FOUNDATION DETAILS (EAST)

STRATA PLAN BCS1114 PHASE 2

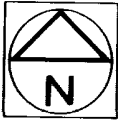

SCALE-1:500



ALL DISTANCES ARE IN METRES

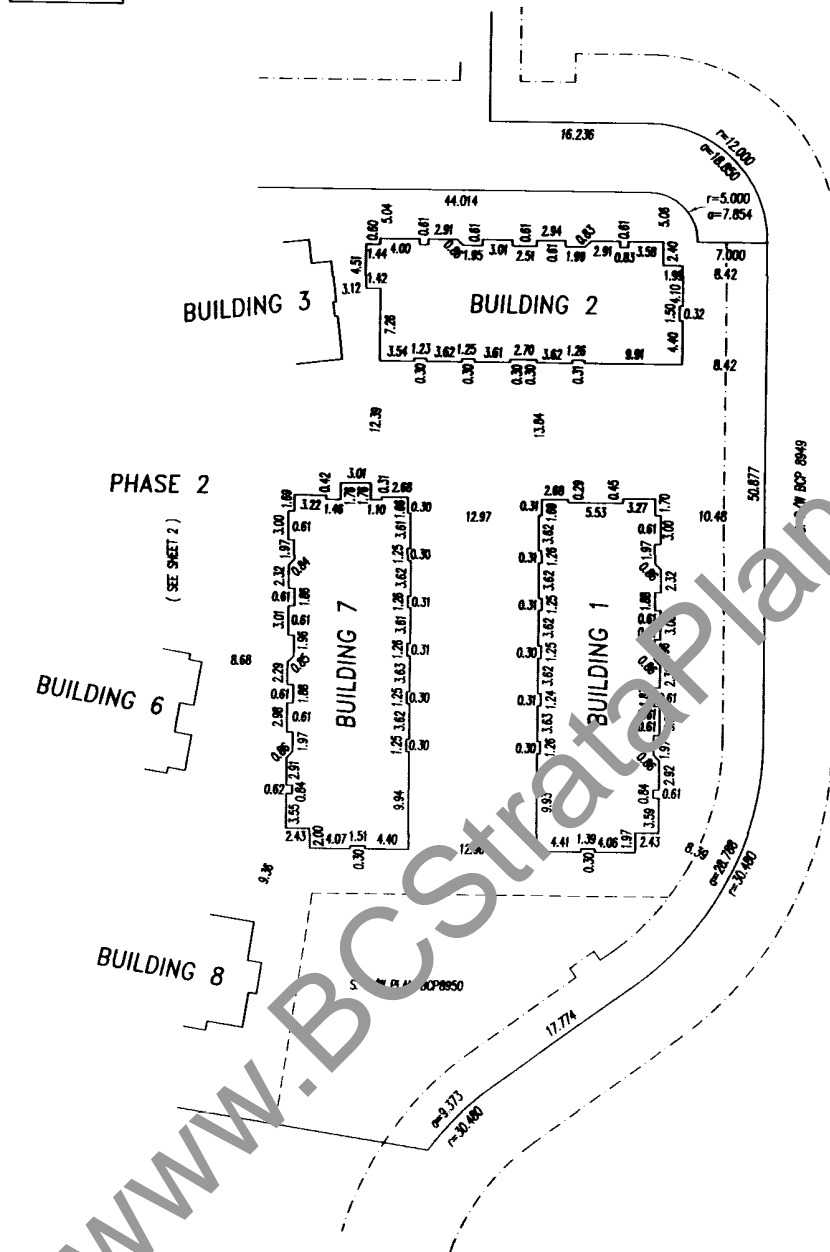

OWNER : POLYGON PHASE DEVELOPMENT LTD., INC. No. 636904

MORTGAGEE: THE BANK OF NOVA SCOTIA

AUTHORIZED SIGNATORY *Ralf Schindt*
RALF SCHINDT

AUTHORIZED SIGNATORY *Patrick Corbin*
PATRICK CORBIN

AUTHORIZED SIGNATORY *Robert Bruno*
ROBERT BRUNO

AUTHORIZED SIGNATORY *Sean-Paul Baker*
Sean-Paul Baker

WITNESS: *[Signature]*

WITNESS: *[Signature]*

Tanya Manic

Danny Atkar

ADDRESS AND OCCUPATION OF WITNESS :

ADDRESS AND OCCUPATION OF WITNESS :

Development Coordinator
900 - 1333 W Broadway
Vancouver BC V6H 4C2

3400 - 650 West Georgia St
Vancouver V6B 4N7
Banker

RJE
DATED THIS 5th DAY OF May 2005

B.C.L.S.

FLOOR PLANS

STRATA PLAN BCS1114 PHASE 2

SCALE 1:200

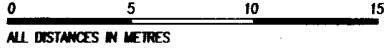

BUILDING 5



GROUND FLOOR

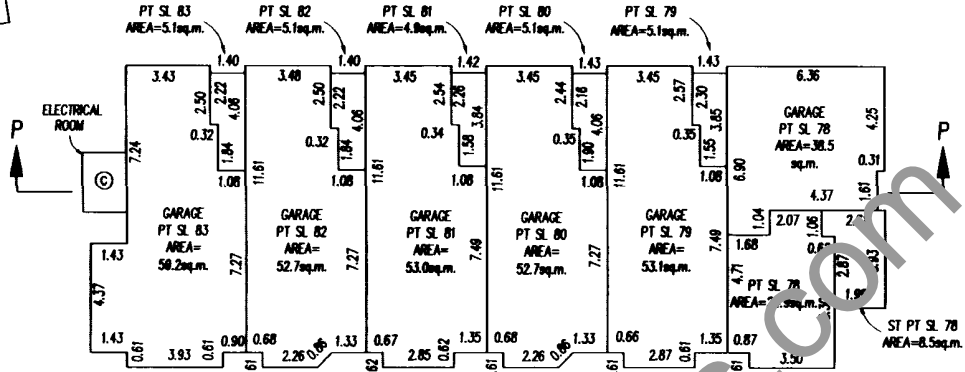

MAIN FLOOR

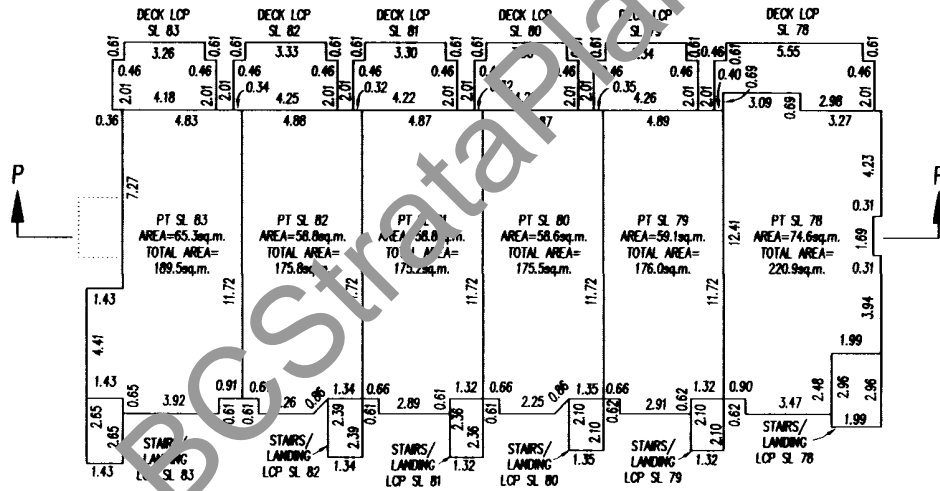

UPPER FLOOR

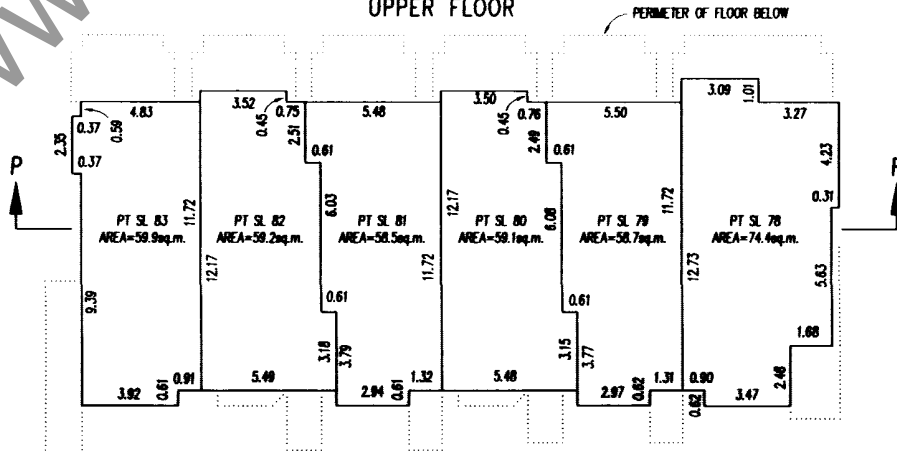

WWW.BCSstrataplans.com

RJE

DATED THIS 5th DAY OF May 2005

B.C.L.S.

FLOOR PLANS

STRATA PLAN BCS1114

PHASE 2

SCALE 1:200



ALL DISTANCES IN METRES

BUILDING 4

GROUND FLOOR

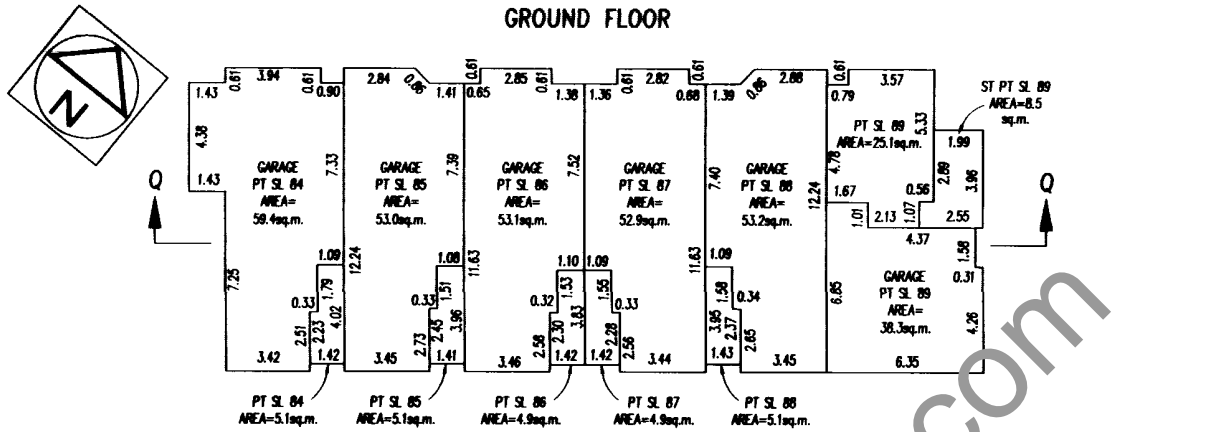

MAIN FLOOR

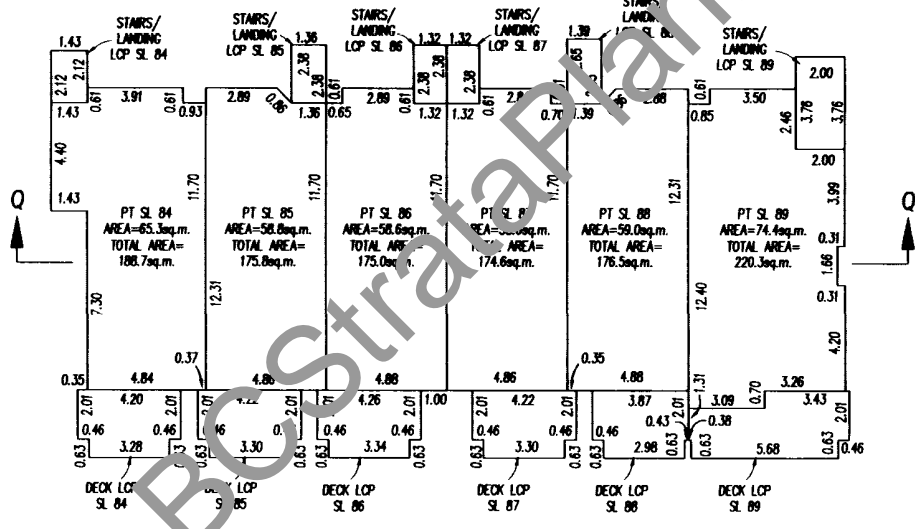

UPPER FLOOR

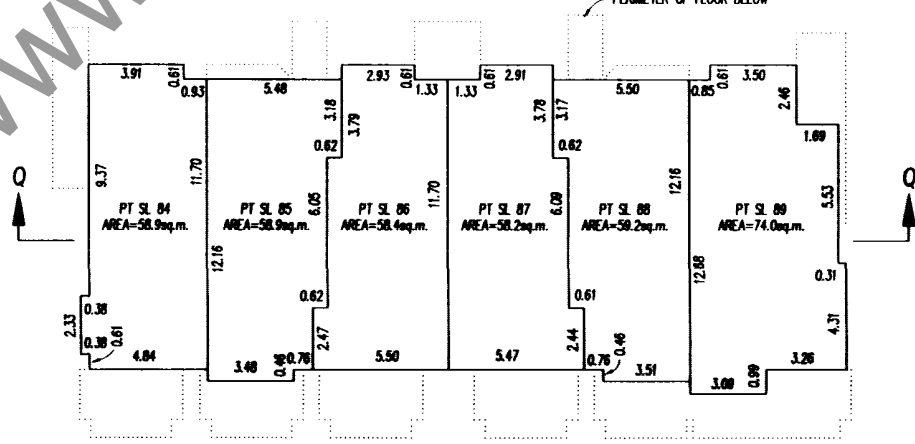

WWW.ECStrataPlans.com

DATED THIS 5th DAY OF May 2005

B.C.L.S.

FLOOR PLANS

STRATA PLAN BCS1114 PHASE 2

BUILDING 3

SCALE 1:200

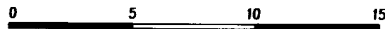

ALL DISTANCES IN METRES

GROUND FLOOR

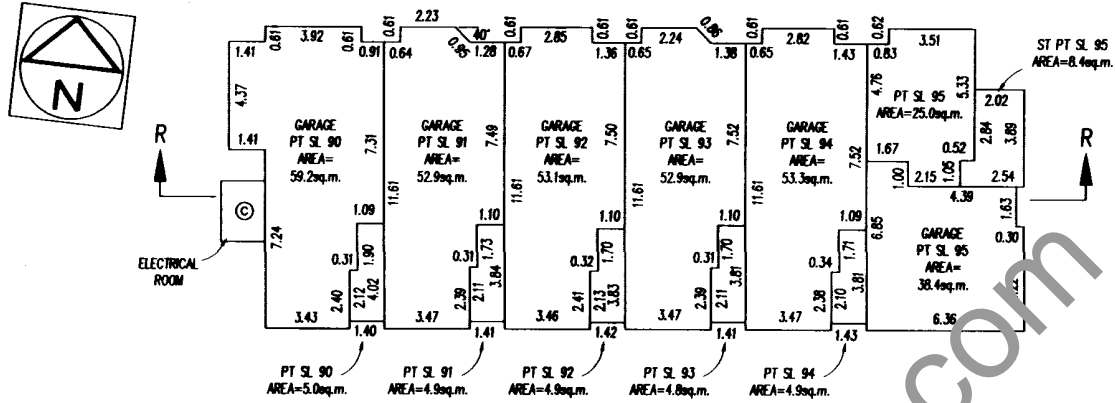

MAIN FLOOR

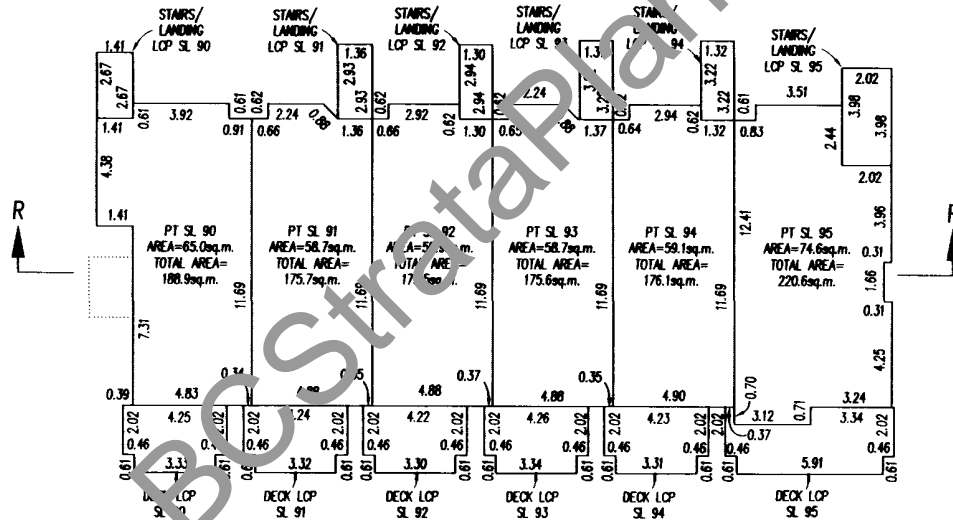

UPPER FLOOR

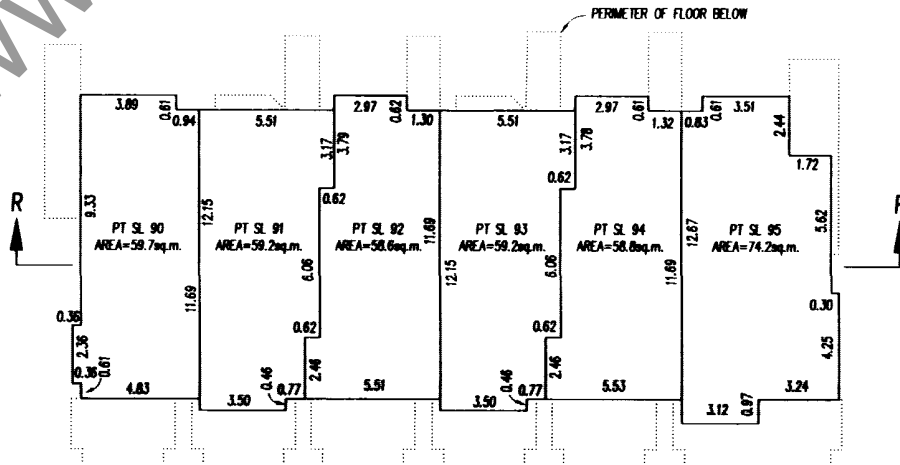

WWW.BCSstrataplans.com

DATED THIS 5th DAY OF May 2005

B.C.L.S.

FLOOR PLANS

STRATA PLAN BCS1114

BUILDING 2

PHASE 2

SCALE 1:200



ALL DISTANCES IN METRES

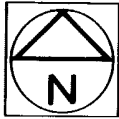

GROUND FLOOR

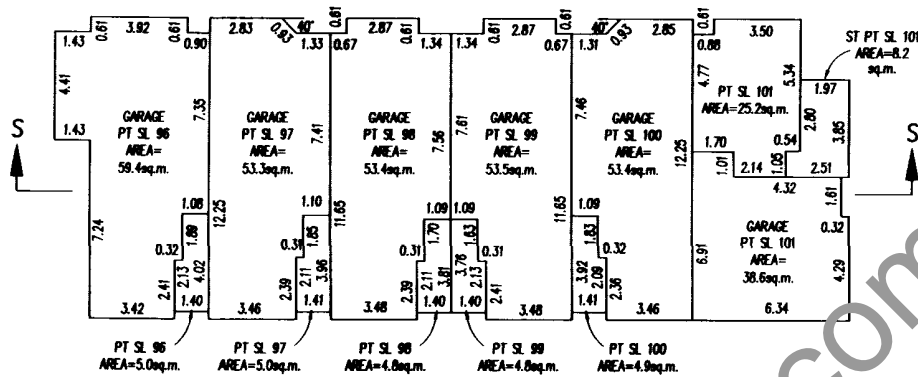

MAIN FLOOR

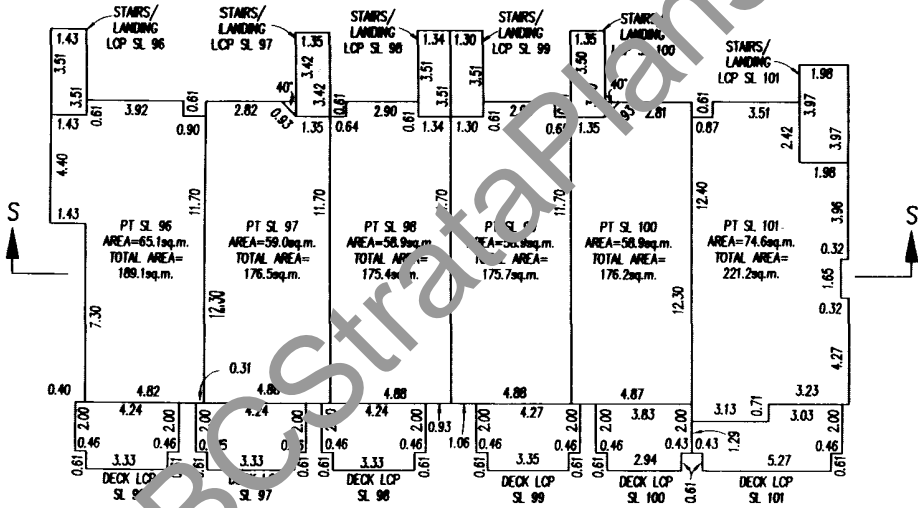

UPPER FLOOR

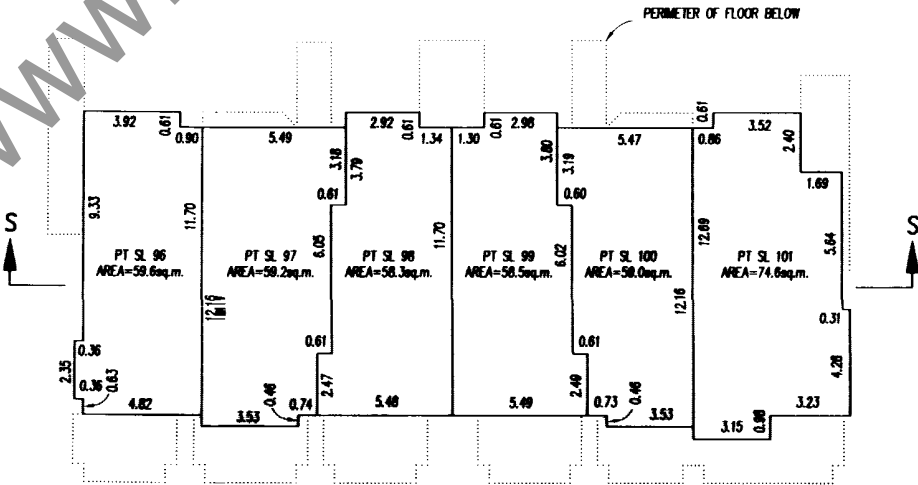

WWW.BCStrataPlans.com

RJE

DATED THIS 5th DAY OF May 2005

B.C.L.S.

FLOOR PLANS

STRATA PLAN BCS1114

PHASE 2

SCALE 1:200



ALL DISTANCES IN METRES

BUILDING 1

GROUND FLOOR

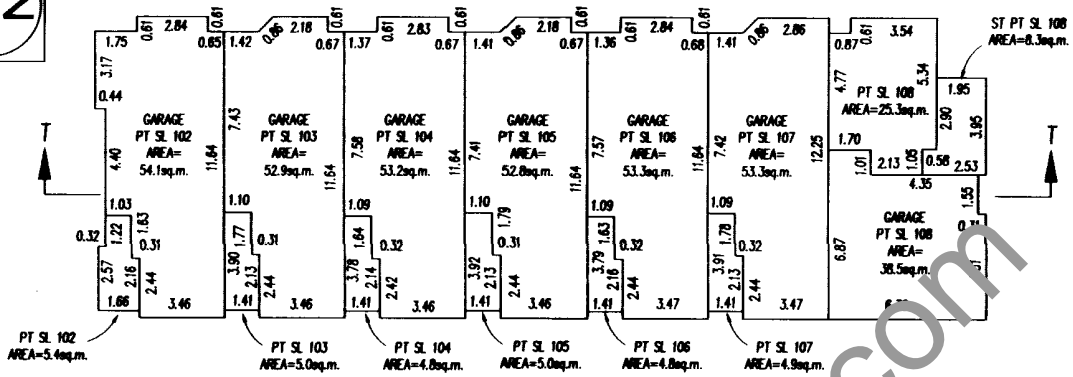
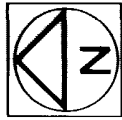

MAIN FLOOR

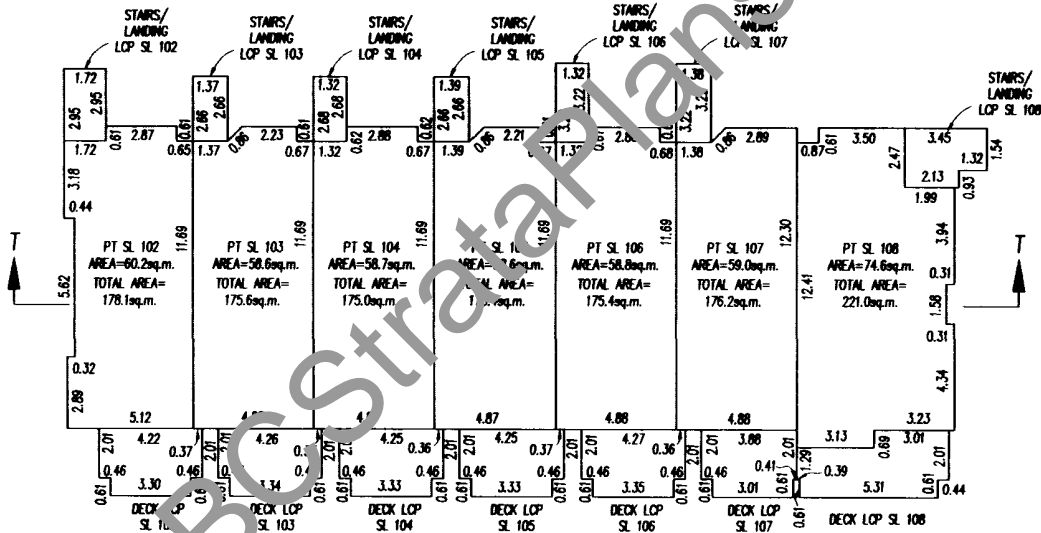

UPPER FLOOR

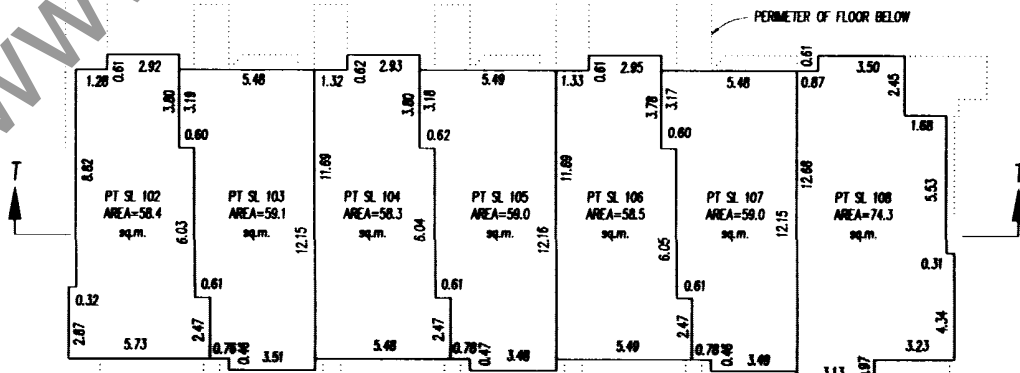

WWW.BCStrataPlans.com

RJE

DATED THIS 5th DAY OF May 2005

B.C.L.S.

FLOOR PLANS

STRATA PLAN BCS1114 PHASE 2

SCALE 1: 200

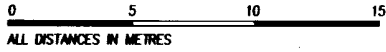

BUILDING 7

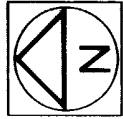

GROUND FLOOR

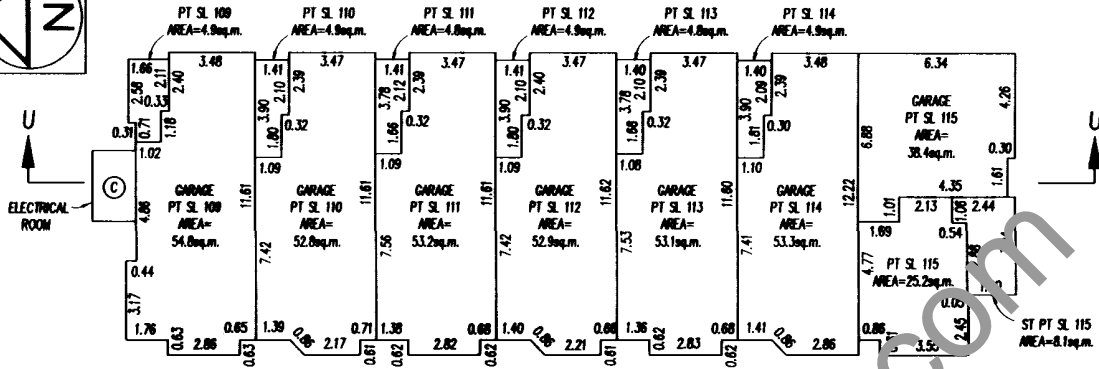

MAIN FLOOR

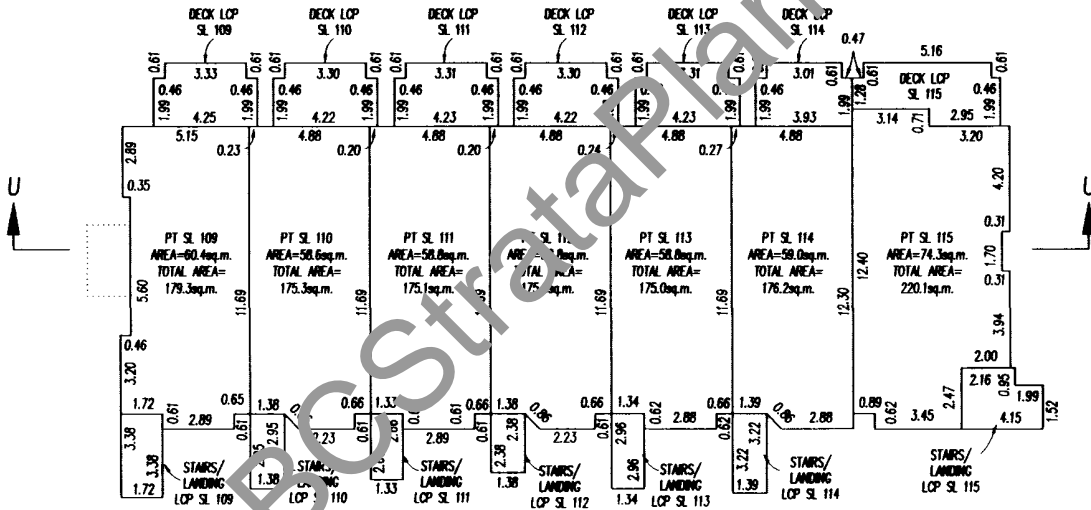

UPPER FLOOR

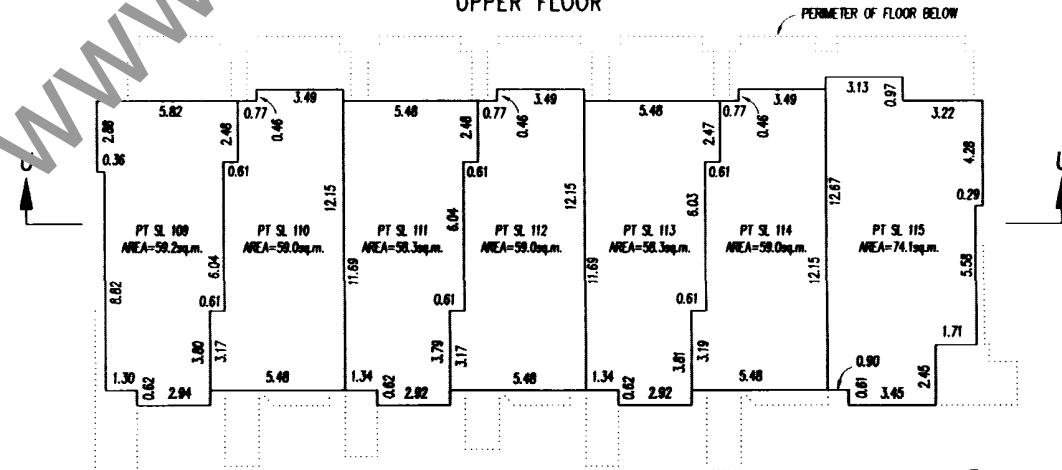

DATED THIS 5th DAY OF May 2005
B.C.L.S.

FLOOR PLANS

SCALE 1:200

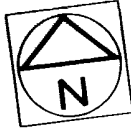
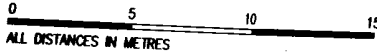

BUILDING 6

STRATA PLAN BCS1114

PHASE 2

GROUND FLOOR

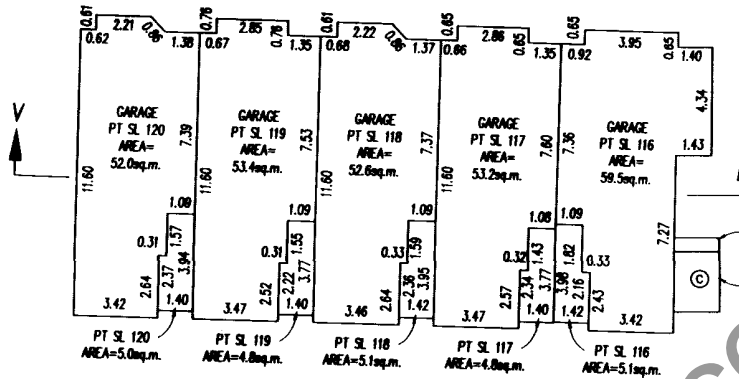

MAIN FLOOR

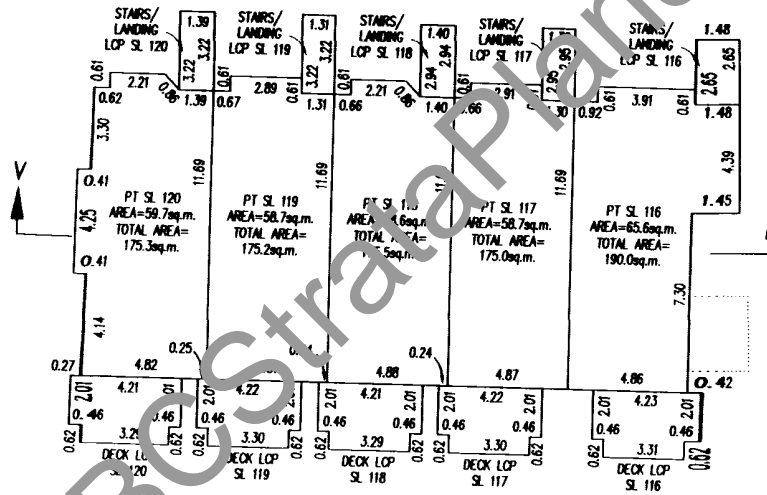

UPPER FLOOR

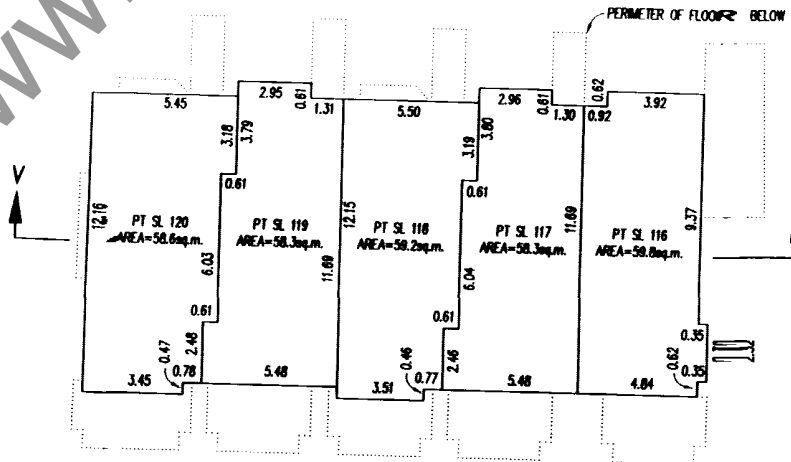

WWW.BCS1114.Plans.com

BJE

B.C.L.S.

DATED THIS 5th DAY OF May 2005

FLOOR PLANS

STRATA PLAN BCS1114 PHASE 2

SCALE 1: 200

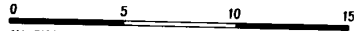

ALL DISTANCES IN METRES

BUILDING 8

GROUND FLOOR

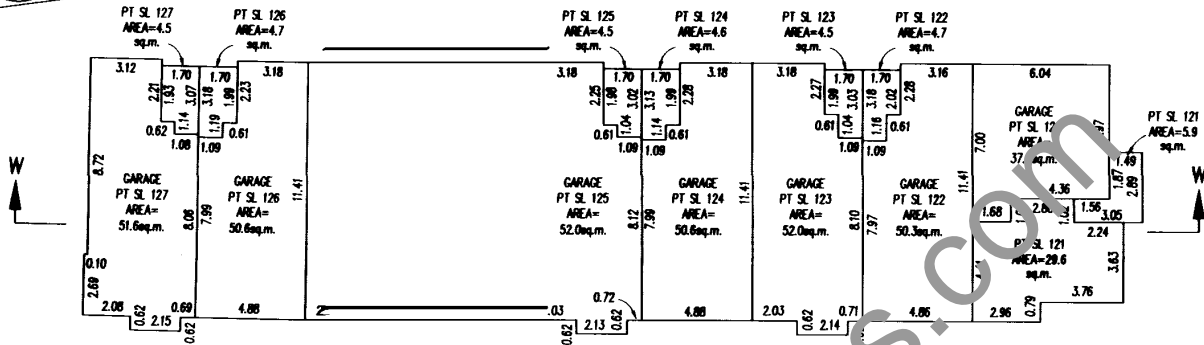
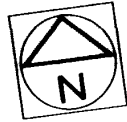

MAIN FLOOR

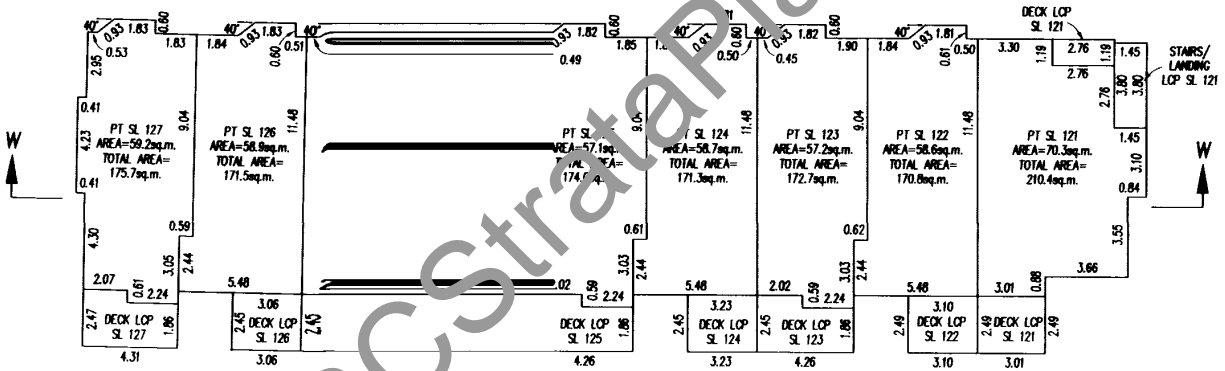

UPPER FLOOR

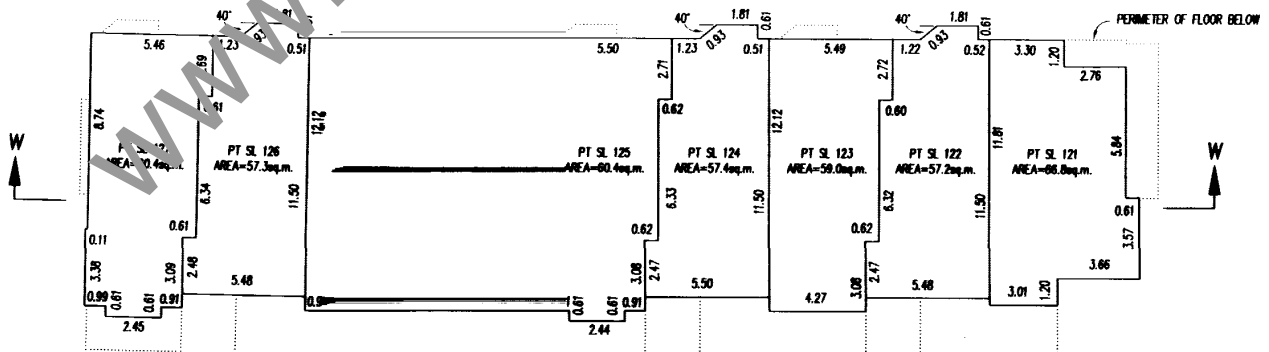

B.C.L.S.
DATED THIS 5th DAY OF May 2005

SECTIONS

STRATA PLAN BCS1114

SCALE-1:200

PHASE 2



BUILDING 5 SECTION P-P

	PT SL 83	PT SL 82	PT SL 81	PT SL 80	PT SL 79	PT SL 78	UPPER FLOOR
	PT SL 83	PT SL 82	PT SL 81	PT SL 80	PT SL 79	PT SL 78	MAIN FLOOR
ELECTRICAL ROOM Ⓢ	GARAGE PT SL 83	GARAGE PT SL 82	GARAGE PT SL 81	GARAGE PT SL 80	GARAGE PT SL 79	GARAGE PT SL 78	GROUND FLOOR GROUND LINE

BUILDING 4 SECTION Q-Q

	PT SL 84	PT SL 85	PT SL 86	PT SL 87	PT SL 88	PT SL 89	UPPER FLOOR
	PT SL 84	PT SL 85	PT SL 86	PT SL 87	PT SL 88	PT SL 89	MAIN FLOOR
	GARAGE PT SL 84	GARAGE PT SL 85	GARAGE PT SL 86	GARAGE PT SL 87	GARAGE PT SL 88	GARAGE PT SL 89	GROUND FLOOR GROUND LINE

BUILDING 3 SECTION R-R

	PT SL 90	PT SL 91	PT SL 92	PT SL 93	PT SL 94	PT SL 95	UPPER FLOOR
	PT SL 90	PT SL 91	PT SL 92	PT SL 93	PT SL 94	PT SL 95	MAIN FLOOR
ELECTRICAL ROOM Ⓢ	GARAGE PT SL 90	GARAGE PT SL 91	GARAGE PT SL 92	GARAGE PT SL 93	GARAGE PT SL 94	GARAGE PT SL 95	GROUND FLOOR GROUND LINE

BUILDING 2 SECTION S-S

	PT SL 96	PT SL 97	PT SL 98	PT SL 99	PT SL 100	PT SL 101	UPPER FLOOR
	PT SL 96	PT SL 97	PT SL 98	PT SL 99	PT SL 100	PT SL 101	MAIN FLOOR
	GARAGE PT SL 96	GARAGE PT SL 97	GARAGE PT SL 98	GARAGE PT SL 99	GARAGE PT SL 100	GARAGE PT SL 101	GROUND FLOOR GROUND LINE

WWW.BCStrataPlans.com

B.C.L.S.
 DATED THIS 5th DAY OF May 2005

SECTIONS

SCALE-1:200



STRATA PLAN BCS1114
PHASE 2

BUILDING 1 SECTION T-T

PT SL 102	PT SL 103	PT SL 104	PT SL 105	PT SL 106	PT SL 107	PT SL 108	UPPER FLOOR
PT SL 102	PT SL 103	PT SL 104	PT SL 105	PT SL 106	PT SL 107	PT SL 108	MAIN FLOOR
GARAGE PT SL 102	GARAGE PT SL 103	GARAGE PT SL 104	GARAGE PT SL 105	GARAGE PT SL 106	GARAGE PT SL 107	GARAGE PT SL 108	GROUND FLOOR GROUND LINE

BUILDING 7 SECTION U-U

	PT SL 109	PT SL 110	PT SL 111	PT SL 112	PT SL 113	PT SL 114	PT SL 115	UPPER FLOOR
	PT SL 109	PT SL 110	PT SL 111	PT SL 112	PT SL 113	PT SL 114	PT SL 115	MAIN FLOOR
ELECTRICAL ROOM Ⓢ	GARAGE PT SL 109	GARAGE PT SL 110	GARAGE PT SL 111	GARAGE PT SL 112	GARAGE PT SL 113	GARAGE PT SL 114	GARAGE PT SL 115	GROUND FLOOR GROUND LINE

BUILDING 6 SECTION V-V

	PT SL 120	PT SL 119	PT SL 118	PT SL 117	PT SL 116	UPPER FLOOR
	PT SL 120	PT SL 119	PT SL 118	PT SL 117	PT SL 116	MAIN FLOOR
	GARAGE PT SL 120	GARAGE PT SL 119	GARAGE PT SL 118	GARAGE PT SL 117	GARAGE PT SL 116	GROUND FLOOR GROUND LINE

BUILDING 8 SECTION W-W

PT SL 127	PT SL 126	PT SL 125	PT SL 124	PT SL 123	PT SL 122	PT SL 121	UPPER FLOOR
PT SL 127	PT SL 126	PT SL 125	PT SL 124	PT SL 123	PT SL 122	PT SL 121	MAIN FLOOR
GARAGE PT SL 127	GARAGE PT SL 126	GARAGE PT SL 125	GARAGE PT SL 124	GARAGE PT SL 123	GARAGE PT SL 122	PT SL 121	GROUND FLOOR GROUND LINE

BJE

B.C.L.S

DATED THIS 5th DAY OF May 2005