

**STRATA PLAN OF LOT A BLOCK 11 DISTRICT LOT 393
GROUP 1 NEW WESTMINSTER DISTRICT PLAN BCP45217
EXCEPT PART IN AIR SPACE PLAN EPP25967
BCGS 92G.025**

SHEET 1 OF 48 SHEETS
STRATA PLAN EPS1133

SCALE 1 : 500



ALL DISTANCES ARE IN METRES AND DECIMALS THEREOF
THE INTENDED PLOT SIZE OF THIS PLAN IS 280mm IN WIDTH
BY 432mm IN HEIGHT (B SIZE) WHEN PLOTTED AT A SCALE OF 1:500

**INTEGRATED SURVEY AREA No. 31. (CITY OF VANCOUVER),
NAD83 (CSRS)**

GRID BEARINGS ARE DERIVED FROM OBSERVATIONS
BETWEEN CONTROL MONUMENTS V-1580 AND V-2732

THIS PLAN SHOWS HORIZONTAL GROUND-LEVEL DISTANCES UNLESS
OTHERWISE SPECIFIED. TO COMPUTE GRID DISTANCES, MULTIPLY
GROUND-LEVEL DISTANCES BY THE AVERAGE COMBINED FACTOR OF
0.9995908 WHICH HAS BEEN DERIVED FROM MONUMENTS V-1580
AND V-2732

2300 KINGSWAY
CIVIC ADDRESS: 4815-4818 ELDORADO MEWS, VANCOUVER, BC

METHOD OF MEASUREMENT:

- TO CENTRELINE OF ALL DEMISING WALLS
BETWEEN STRATA LOTS AND ALL STRATA LOT
WALLS ADJOINING COMMON AREAS
- TO ONE (1) CENTIMETRE INSIDE OF THE
OUTSIDE FACE OF EXTERIOR WALLS
- TO FACE OF CONCRETE WALLS WHERE
STRATA LOTS ADJOIN CORE WALLS
(IE ELEVATOR, STAIRWELL).

FOR EXTERIOR BUILDING DIMENSIONS,
SEE SHEET 5 OF 48

NOTES:
UNLESS OTHERWISE NOTED, ALL ANGLES OF STRATA LOT BOUNDARIES
ARE 90° OR 45°

SOME SYMBOLS AND LINES MAY BE EXAGGERATED FOR CLARITY.

THE BUILDINGS INCLUDED IN THIS STRATA PLAN HAVE NOT BEEN
PREVIOUSLY OCCUPIED.

THE BUILDINGS SHOWN HEREON ARE WITHIN THE EXTERNAL BOUNDARIES
OF THE LAND THAT IS THE SUBJECT OF THE STRATA PLAN

THE FIELD SURVEY REPRESENTED BY THIS PLAN WAS COMPLETED BY
JAMES G. SHAW, BCLS, CLS ON THE 6th DAY OF FEBRUARY, 2013

THIS PLAN LIES WITHIN THE GREATER VANCOUVER REGIONAL DISTRICT - CITY OF VANCOUVER

LEGEND

- | | | | |
|------|--------------------------|------|--|
| ⊙ | CONTROL MONUMENT FOUND | PT | DENOTES PART |
| ● | STANDARD IRON POST FOUND | REM | DENOTES REMAINDER |
| ■ | LEAD PLUG FOUND | SL | DENOTES STRATA LOT |
| ASP | DENOTES AIR SPACE PARCEL | ST | DENOTES STAIRS |
| B | DENOTES BALCONY | T | DENOTES TERRACE |
| CORR | DENOTES CORRIDOR | VEST | DENOTES VESTIBULE |
| ELEC | DENOTES ELECTRICAL | VOL | DENOTES VOLUMETRIC |
| ELEV | DENOTES ELEVATOR | WC | DENOTES WASHROOM |
| LOB | DENOTES LOBBY | ⊙ | DENOTES COMMON PROPERTY |
| MACH | DENOTES MACHINE | Ⓢ | DENOTES LIMITED COMMON PROPERTY
FOR STRATA LOT 31 (TYPICAL) |
| MECH | DENOTES MECHANICAL | | |
| PCL | DENOTES PARCEL | | |

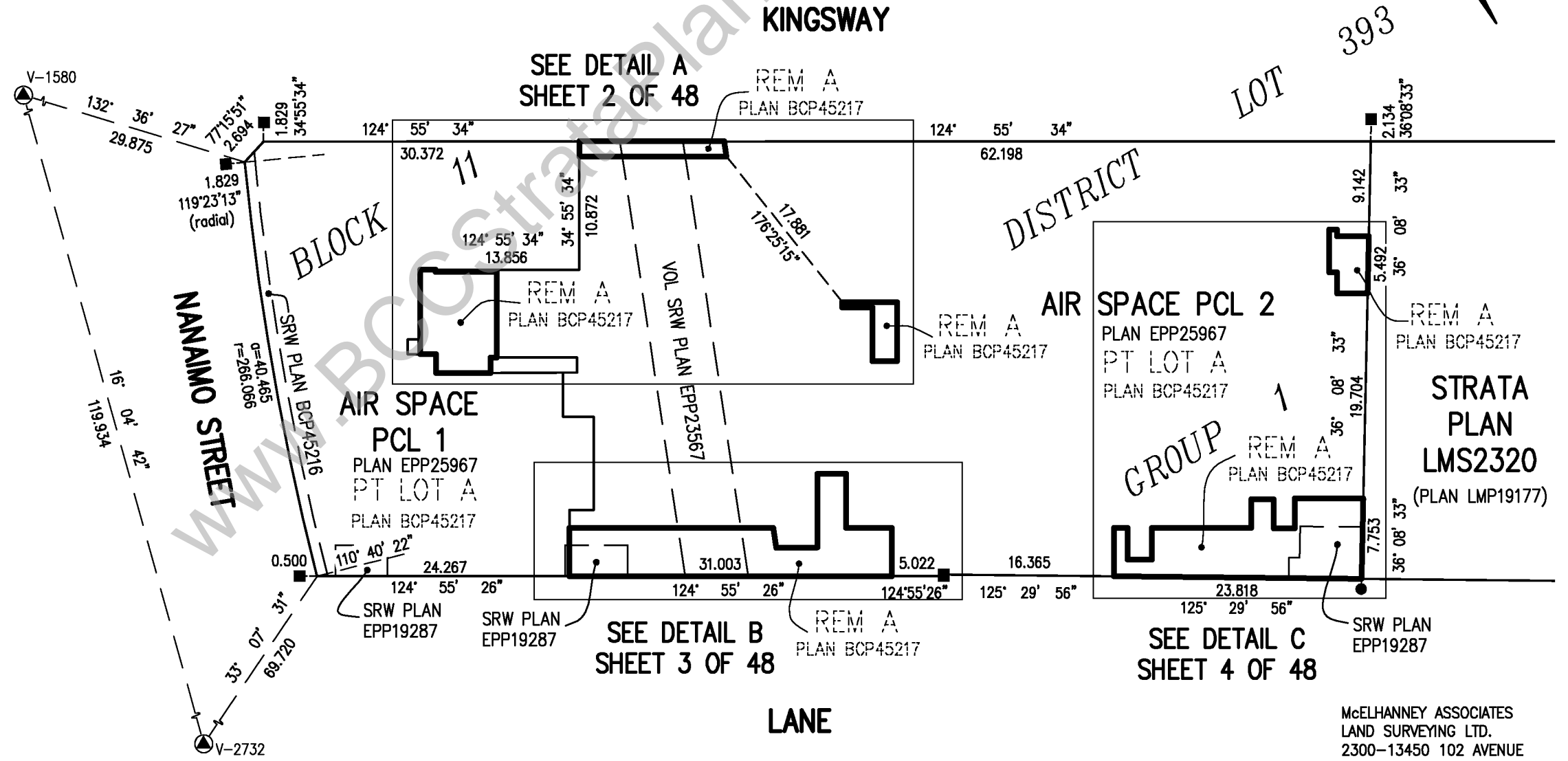
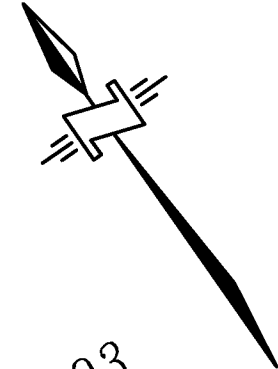

McELHANNEY ASSOCIATES
LAND SURVEYING LTD.
2300-13450 102 AVENUE
SURREY, BC V3T 5X3
TEL: 604-596-0391
FILE: 2112-07909-24
ECP DATE: 25 FEBRUARY 2013

DIMENSIONS DETAIL A

SCALE 1 : 150



ALL DISTANCES ARE IN METRES AND DECIMALS THEREOF
 THE INTENDED PLOT SIZE OF THIS PLAN IS 280mm IN WIDTH
 BY 432mm IN HEIGHT (B SIZE) WHEN PLOTTED AT A SCALE OF 1:150

LEGEND

- REM _____ DENOTES REMAINDER
- SRW _____ DENOTES STATUTORY RIGHT OF WAY
- VOL _____ DENOTES VOLUMETRI

SHEET 2 OF 48 SHEETS
STRATA PLAN EPS1133

KINGSWAY

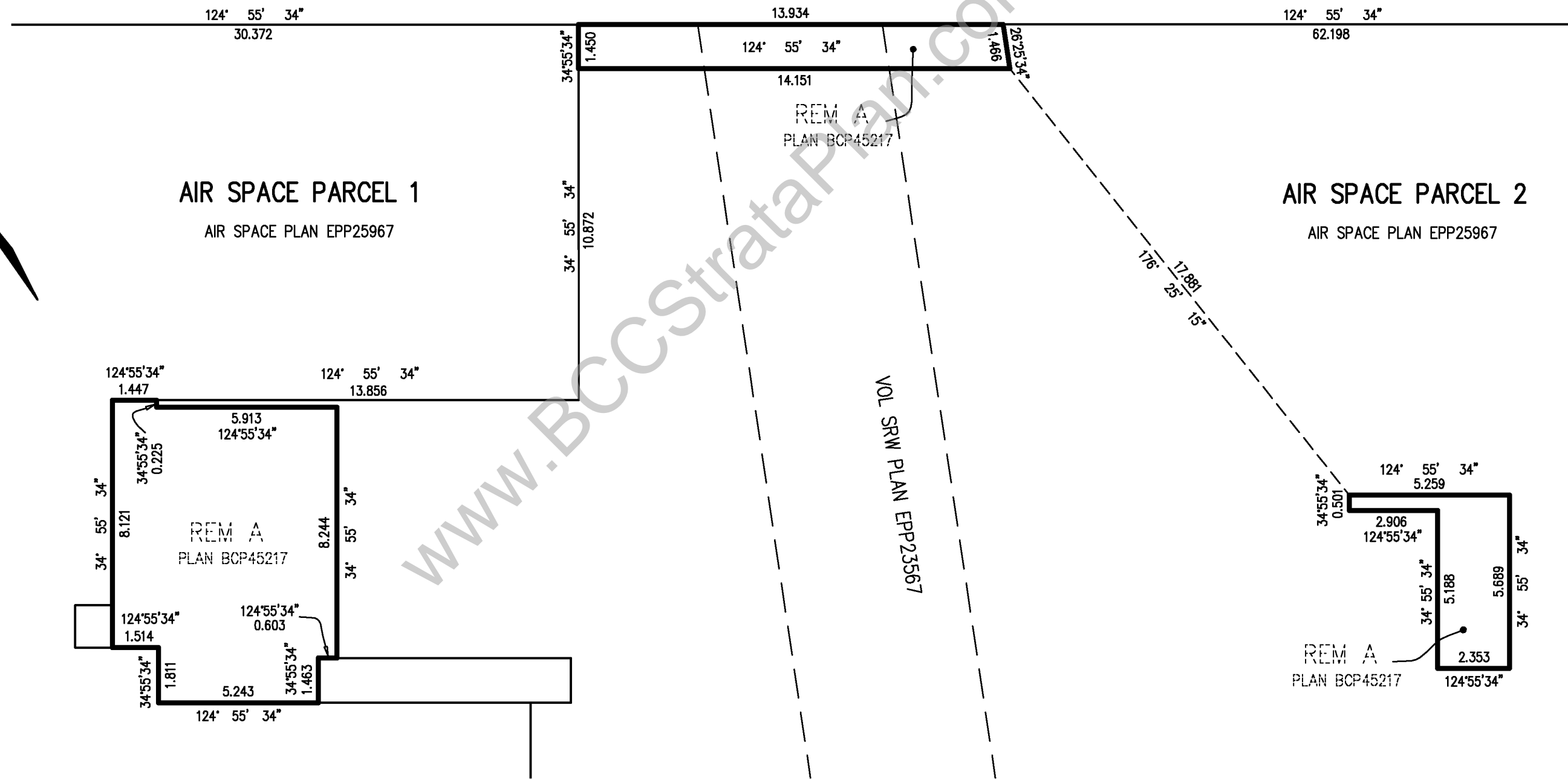
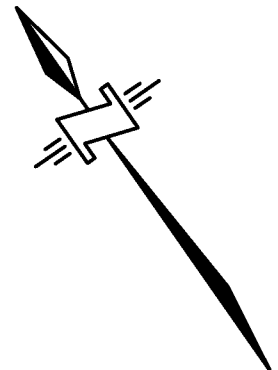

JAMES G. SHAW, BCLS, CLS
 DATE: FEBRUARY 25, 2013
 McELHANNEY ASSOCIATES
 LAND SURVEYING LTD.
 FILE: 2112-07909-24

DIMENSIONS DETAIL B

SCALE 1 : 150

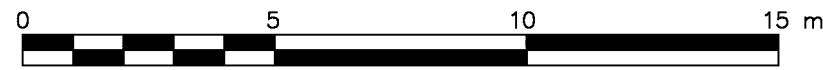

ALL DISTANCES ARE IN METRES AND DECIMALS THEREOF
 THE INTENDED PLOT SIZE OF THIS PLAN IS 280mm IN WIDTH
 BY 432mm IN HEIGHT (B SIZE) WHEN PLOTTED AT A SCALE OF 1:150

LEGEND

- LEAD PLUG FOUND
- REM _____ DENOTES REMAINDER
- SRW _____ DENOTES STATUTORY RIGHT OF WAY
- VOL _____ DENOTES VOLUMETRI

NOTE: SOME SYMBOLS AND LINES MAY BE EXAGGERATED FOR CLARITY.

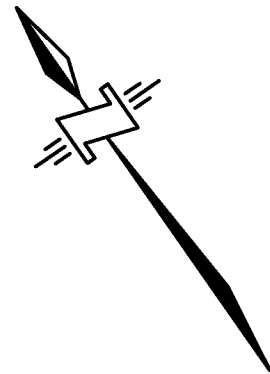

AIR SPACE PARCEL 1

AIR SPACE PLAN EPP25967

AIR SPACE PARCEL 2

AIR SPACE PLAN EPP25967

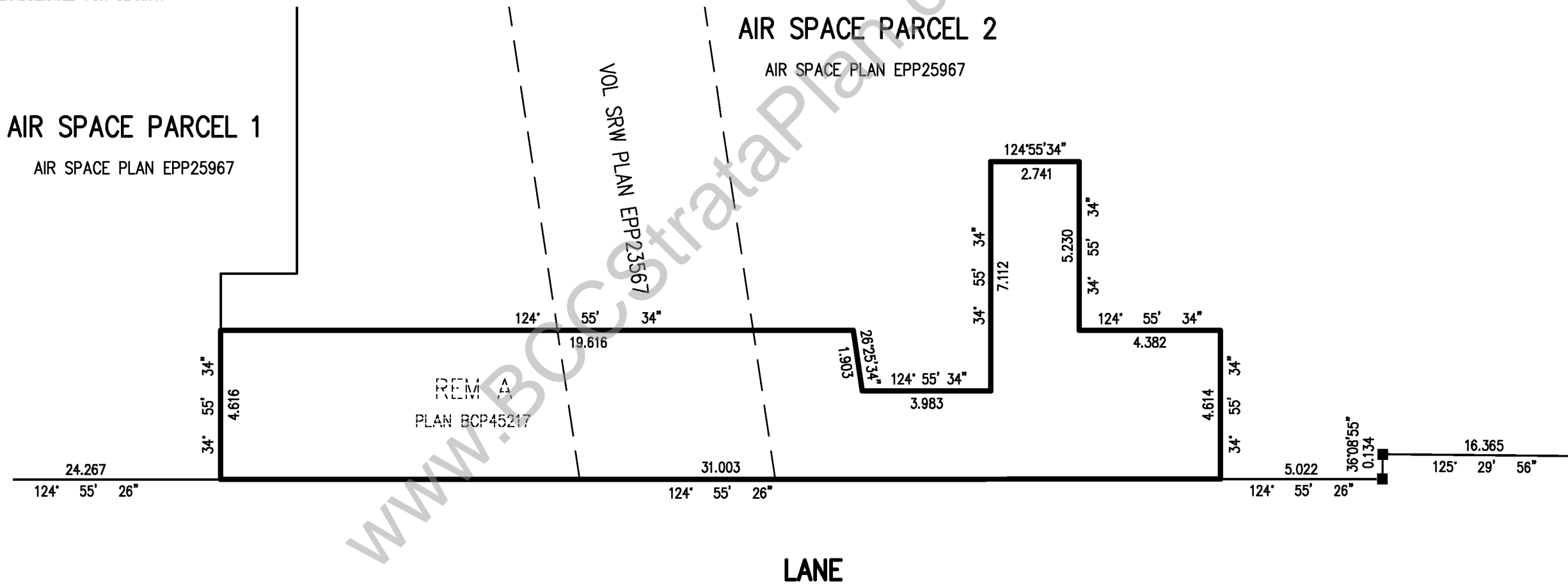

JAMES G. SHAW, BCLS, CLS
 DATE: FEBRUARY 25, 2013
 McELHANNEY ASSOCIATES
 LAND SURVEYING LTD.
 FILE: 2112-07909-24

SHEET 3 OF 48 SHEETS
STRATA PLAN EPS1133

FOUNDATION

SCALE 1 : 300



ALL DISTANCES ARE IN METRES AND DECIMALS THEREOF

THE INTENDED PLOT SIZE OF THIS PLAN IS 280mm IN WIDTH BY 432mm IN HEIGHT (B SIZE) WHEN PLOTTED AT A SCALE OF 1:300

ALL ANGLES ARE 45° OR 90° UNLESS OTHERWISE STATED

SHEET 5 OF 48 SHEETS STRATA PLAN EPS1133

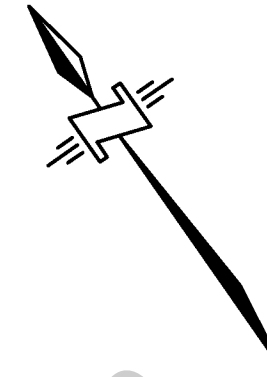

KINGSWAY

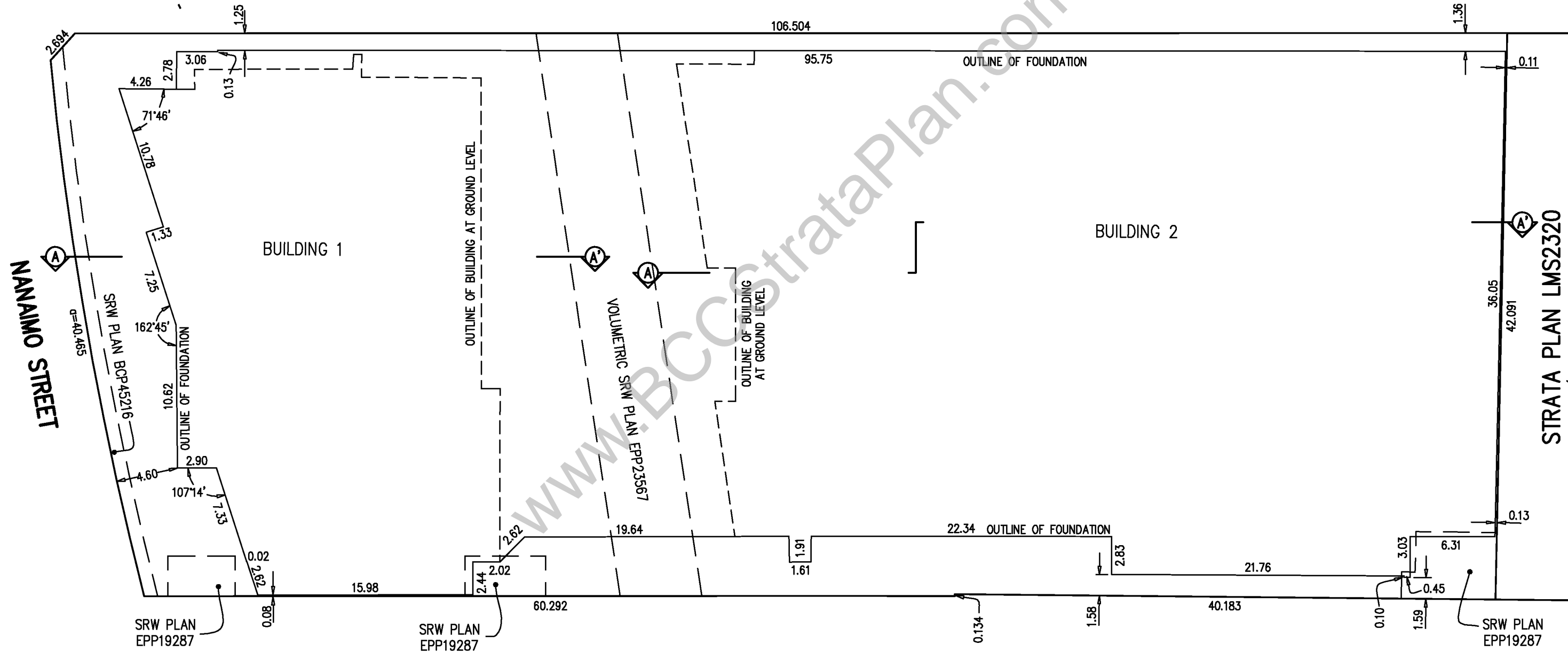

JAMES G. SHAW, BCLS, CLS
 DATE: FEBRUARY 25, 2013
 McELHANNEY ASSOCIATES
 LAND SURVEYING LTD.
 FILE: 2112-07909-24

PARKING LEVEL 5

SCALE 1 : 300

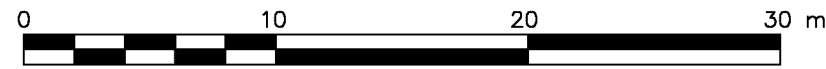

ALL DISTANCES ARE IN METRES AND DECIMALS THEREOF
 THE INTENDED PLOT SIZE OF THIS PLAN IS 280mm IN WIDTH
 BY 432mm IN HEIGHT (B SIZE) WHEN PLOTTED AT A SCALE OF 1:300

LEGEND

- CORR _____ DENOTES CORRIDOR
- MACH _____ DENOTES MACHINE
- VEST _____ DENOTES VESTIBULE
- Ⓢ _____ COMMON PROPERTY

SHEET 6 OF 48 SHEETS
STRATA PLAN EPS1133

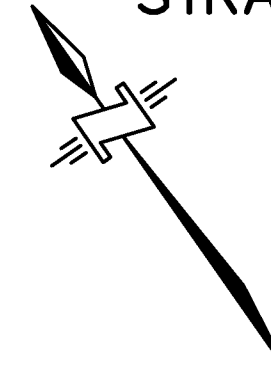

KINGSWAY

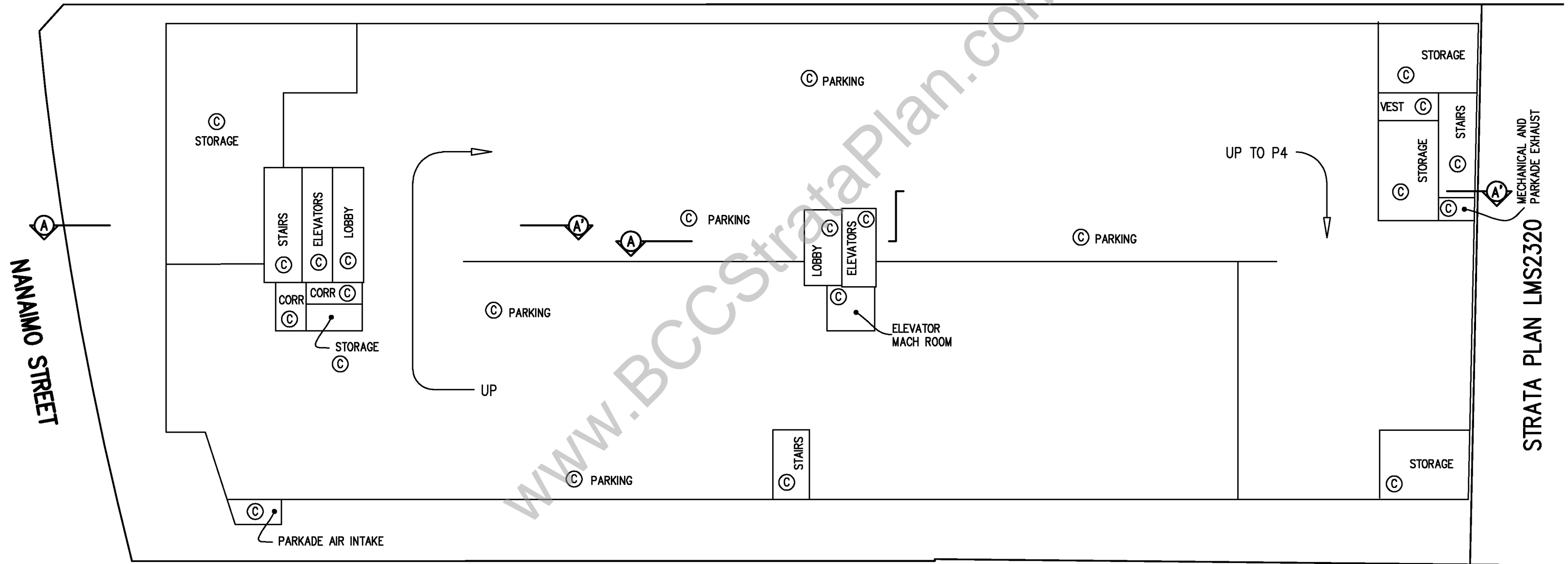

STRATA PLAN LMS2320

LANE

JAMES G. SHAW, BCLS, CLS
 DATE: FEBRUARY 25, 2013
 McELHANNEY ASSOCIATES
 LAND SURVEYING LTD.
 FILE: 2112-07909-24

PARKING LEVEL 4

SCALE 1 : 300

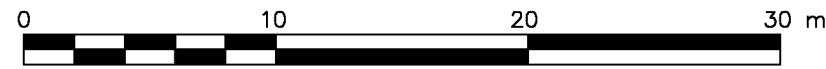

ALL DISTANCES ARE IN METRES AND DECIMALS THEREOF
 THE INTENDED PLOT SIZE OF THIS PLAN IS 280mm IN WIDTH
 BY 432mm IN HEIGHT (B SIZE) WHEN PLOTTED AT A SCALE OF 1:300

LEGEND

- CORR _____ DENOTES CORRIDOR
- VEST _____ DENOTES VESTIBULE
- Ⓢ _____ COMMON PROPERTY

SHEET 7 OF 48 SHEETS
STRATA PLAN EPS1133

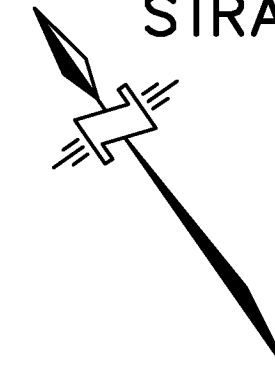

KINGSWAY

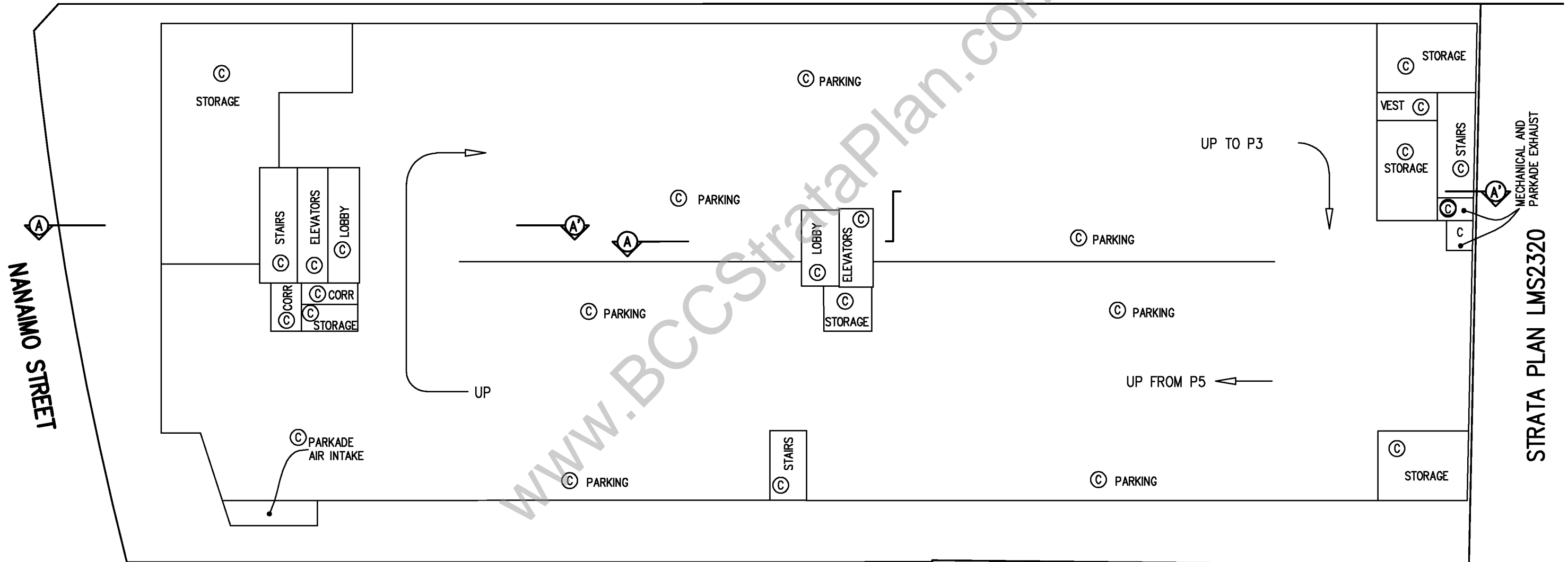

STRATA PLAN LMS2320

LANE

JAMES G. SHAW, BCLS, CLS
 DATE: FEBRUARY 25, 2013
 McELHANNEY ASSOCIATES
 LAND SURVEYING LTD.
 FILE: 2112-07909-24

PARKING LEVEL 3

SCALE 1 : 300

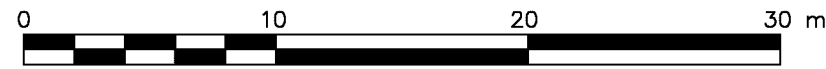

ALL DISTANCES ARE IN METRES AND DECIMALS THEREOF
 THE INTENDED PLOT SIZE OF THIS PLAN IS 280mm IN WIDTH
 BY 432mm IN HEIGHT (B SIZE) WHEN PLOTTED AT A SCALE OF 1:300

LEGEND

- CORR _____ DENOTES CORRIDOR
- VEST _____ DENOTES VESTIBULE
- ASP _____ DENOTES AIR SPACE PARCEL
- Ⓢ _____ COMMON PROPERTY

SHEET 8 OF 48 SHEETS
STRATA PLAN EPS1133

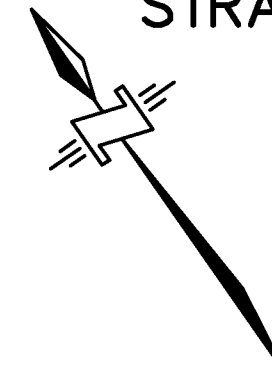

KINGSWAY

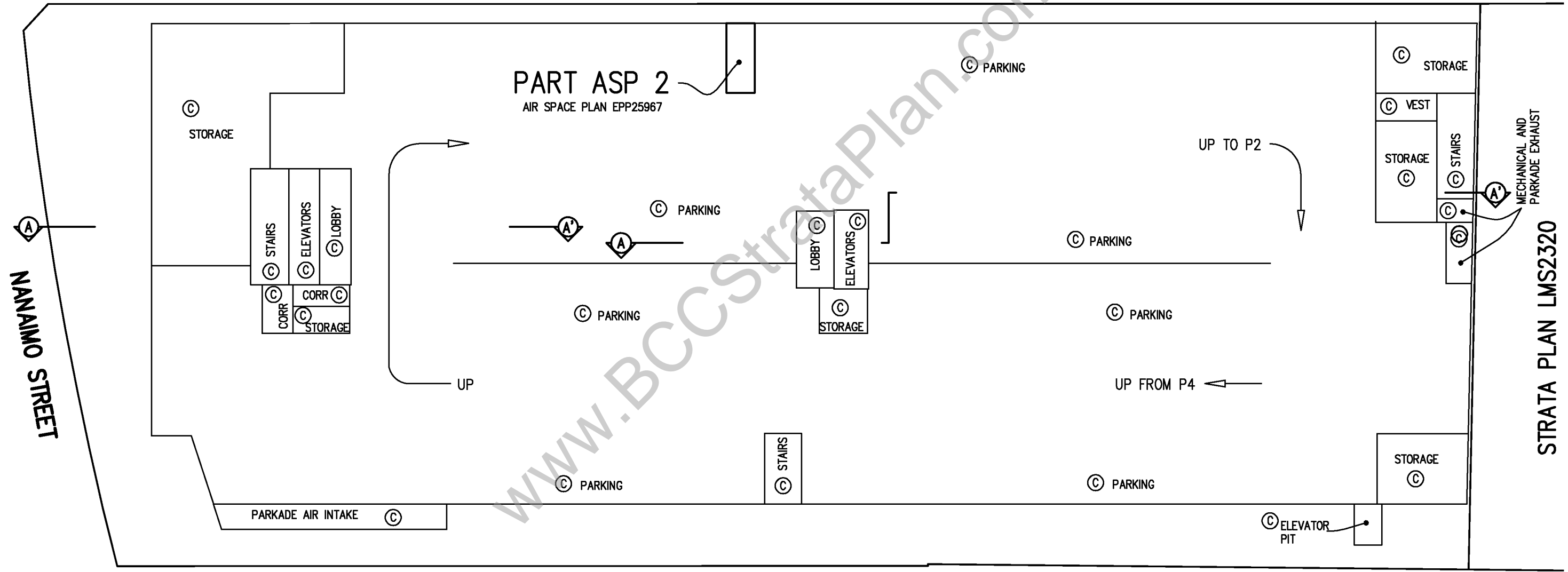

STRATA PLAN LMS2320

LANE

JAMES G. SHAW, BCLS, CLS
 DATE: FEBRUARY 25, 2013
 McELHANNEY ASSOCIATES
 LAND SURVEYING LTD.
 FILE: 2112-07909-24

PARKING LEVEL 2

SCALE 1 : 300

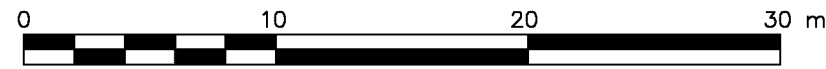

ALL DISTANCES ARE IN METRES AND DECIMALS THEREOF
 THE INTENDED PLOT SIZE OF THIS PLAN IS 280mm IN WIDTH
 BY 432mm IN HEIGHT (B SIZE) WHEN PLOTTED AT A SCALE OF 1:300

LEGEND

- ELEV _____ DENOTES ELEVATOR
- MECH _____ DENOTES MECHANICAL
- VEST _____ DENOTES VESTIBULE
- ASP _____ DENOTES AIR SPACE PARCEL
- Ⓢ _____ COMMON PROPERTY

SHEET 9 OF 48 SHEETS
STRATA PLAN EPS1133

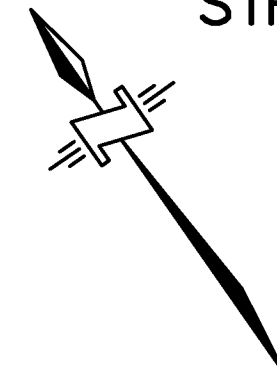

KINGSWAY

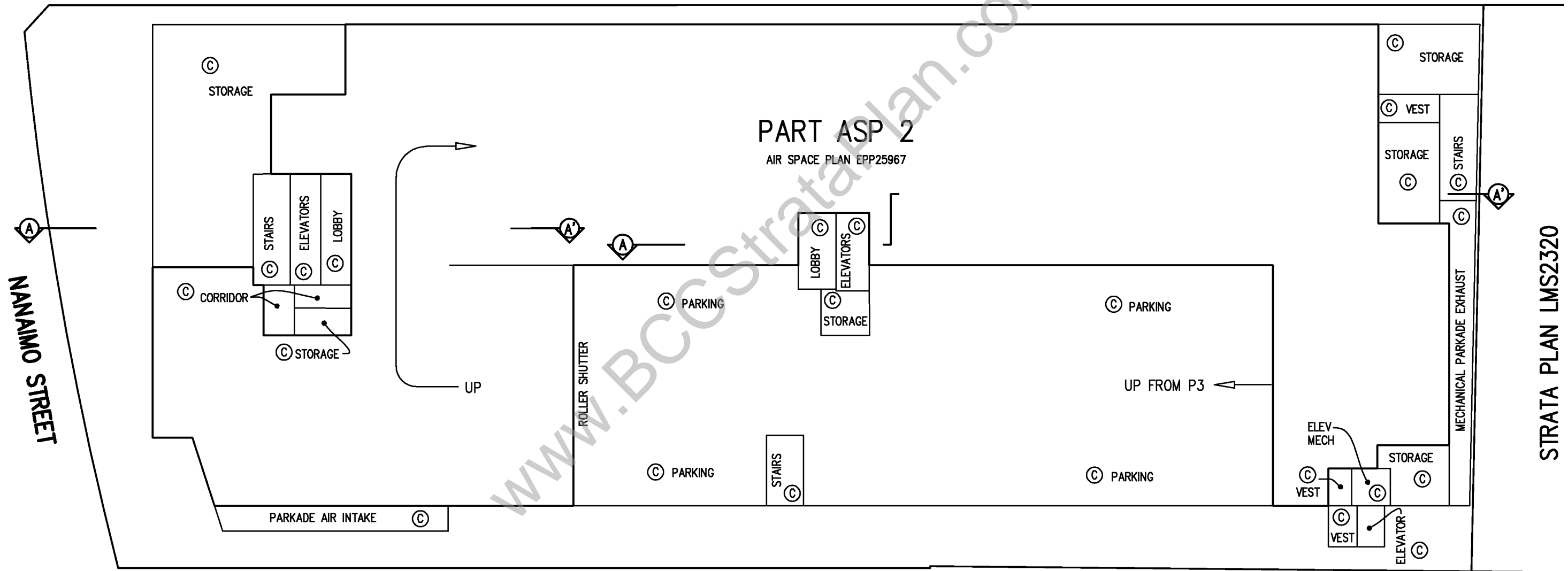

STRATA PLAN LMS2320

LANE

JAMES G. SHAW, BCLS, CLS
 DATE: FEBRUARY 25, 2013
 McELHANNEY ASSOCIATES
 LAND SURVEYING LTD.
 FILE: 2112-07909-24

PARKING LEVEL 1

SCALE 1 : 300



ALL DISTANCES ARE IN METRES AND DECIMALS THEREOF
 THE INTENDED PLOT SIZE OF THIS PLAN IS 280mm IN WIDTH
 BY 432mm IN HEIGHT (B SIZE) WHEN PLOTTED AT A SCALE OF 1:300

LEGEND

- MECH _____ DENOTES MECHANICA
- VEST _____ DENOTES VESTIBULE
- ASP _____ DENOTES AIR SPACE PARCEL
- TEL _____ DENOTES TELEPHONE ROOM
- COMM _____ DENOTES COMMUNICATIONS ROOM
- TV _____ DENOTES TELEVISION ROOM
- Ⓢ _____ COMMON PROPERTY

SHEET 10 OF 48 SHEETS

STRATA PLAN EPS1133

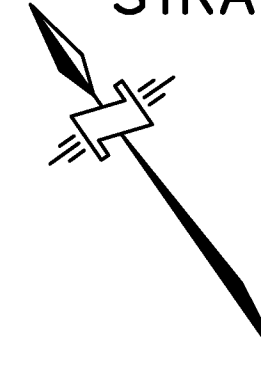

KINGSWAY

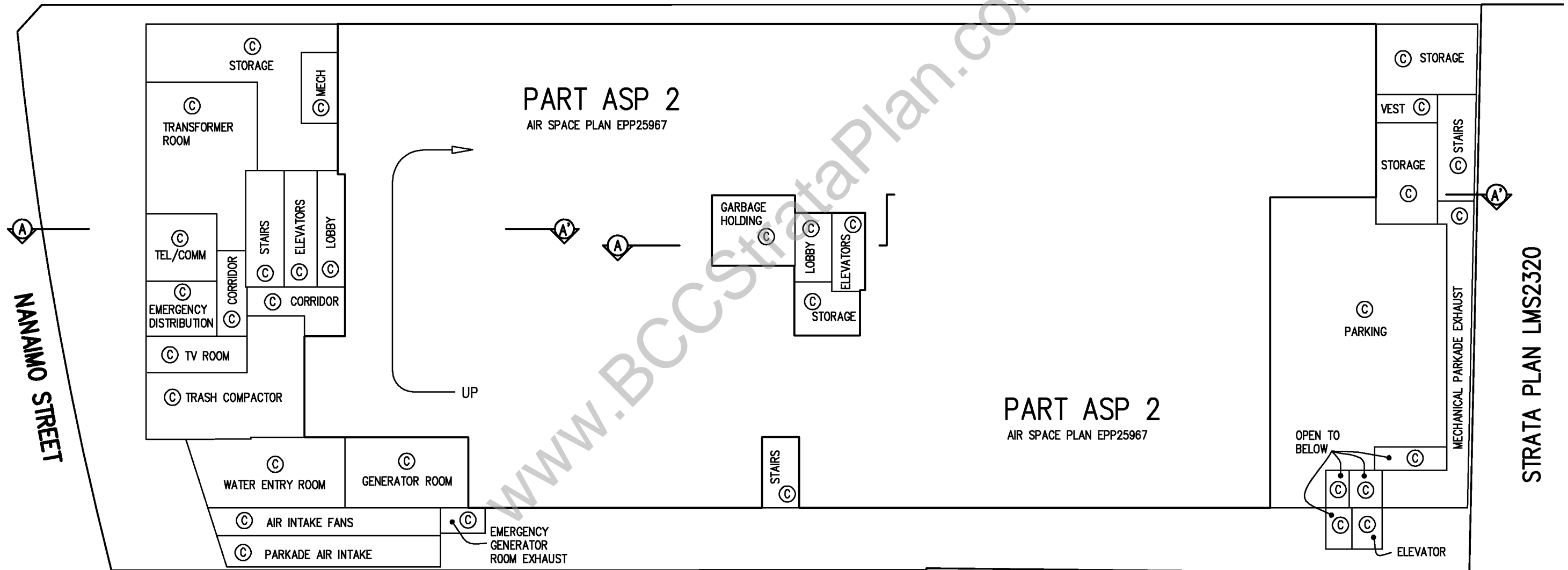

LANE

JAMES G. SHAW, BCLS, CLS
 DATE: FEBRUARY 25, 2013
 McELHANNEY ASSOCIATES
 LAND SURVEYING LTD.
 FILE: 2112-07909-24

BUILDING 1 GROUND FLOOR

SHEET 11 OF 48 SHEETS
STRATA PLAN EPS1133

SCALE 1 : 200

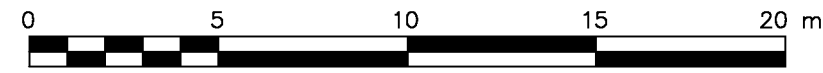

ALL DISTANCES ARE IN METRES AND DECIMALS THEREOF
THE INTENDED PLOT SIZE OF THIS PLAN IS 280mm IN WIDTH
BY 432mm IN HEIGHT (B SIZE) WHEN PLOTTED AT A SCALE OF 1:200

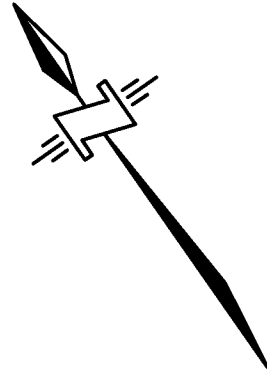

LEGEND

Ⓢ COMMON PROPERTY

KINGSWAY

AIR SPACE PARCEL 1

AIR SPACE PLAN EPP25967

NANAIMO STREET

LANE

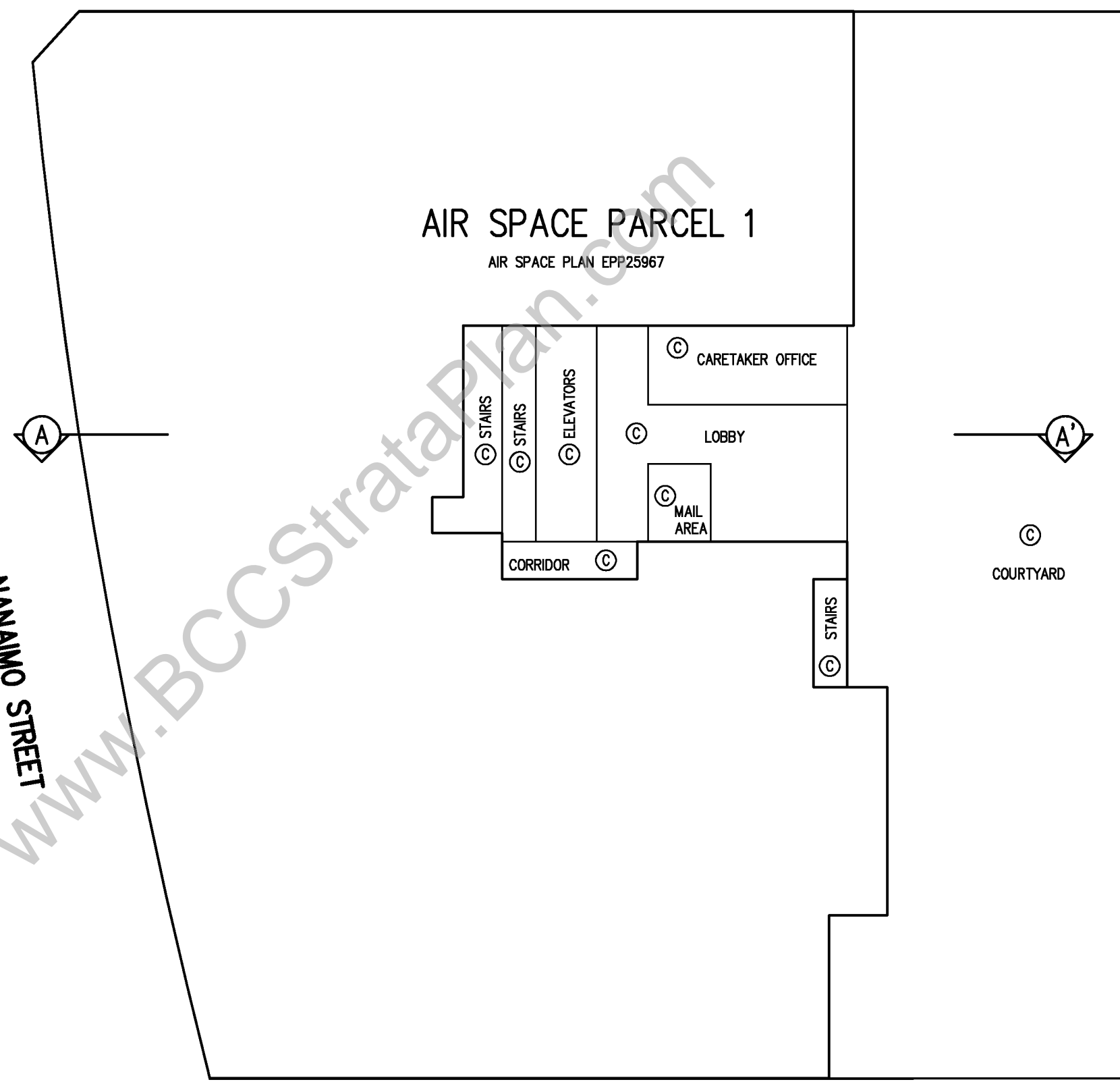

JAMES G. SHAW, BCLS, CLS
DATE: FEBRUARY 25, 2013
McELHANNEY ASSOCIATES
LAND SURVEYING LTD.
FILE: 2112-07909-24

BUILDING 1 GROUND FLOOR MEZZANINE

SHEET 12 OF 48 SHEETS
STRATA PLAN EPS1133

SCALE 1 : 200

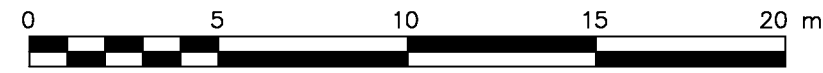

ALL DISTANCES ARE IN METRES AND DECIMALS THEREOF
THE INTENDED PLOT SIZE OF THIS PLAN IS 280mm IN WIDTH
BY 432mm IN HEIGHT (B SIZE) WHEN PLOTTED AT A SCALE OF 1:200

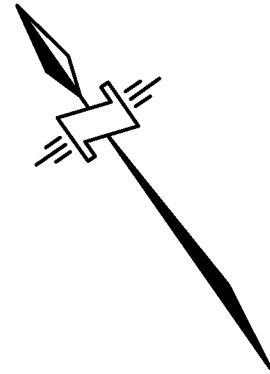

LEGEND

Ⓢ COMMON PROPERTY

KINGSWAY

AIR SPACE PARCEL 1

AIR SPACE PLAN EPP25967



NANAIMO STREET

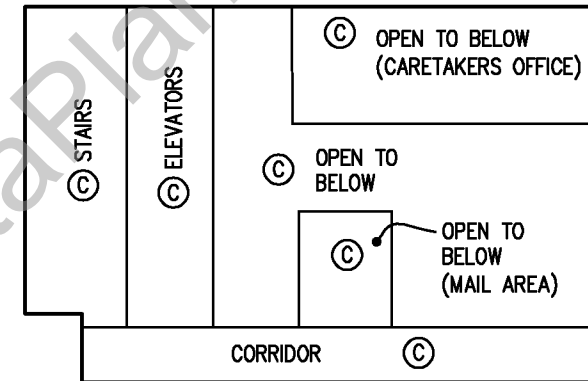
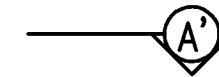

LANE

JAMES G. SHAW, BCLS, CLS
DATE: FEBRUARY 25, 2013
McELHANNEY ASSOCIATES
LAND SURVEYING LTD.
FILE: 2112-07909-24

www.BCCStrataPlan.com

BUILDING 1 LEVEL 2

SHEET 13 OF 48 SHEETS
STRATA PLAN EPS1133

SCALE 1 : 200

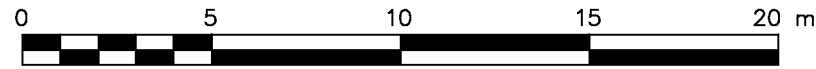

ALL DISTANCES ARE IN METRES AND DECIMALS THEREOF
THE INTENDED PLOT SIZE OF THIS PLAN IS 280mm IN WIDTH
BY 432mm IN HEIGHT (B SIZE) WHEN PLOTTED AT A SCALE OF 1:200

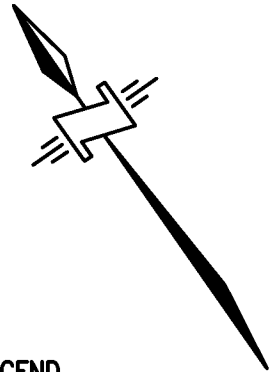

METHOD OF MEASUREMENT:

- TO CENTRELINE OF ALL DEMISING WALLS BETWEEN STRATA LOTS AND ALL STRATA LOT WALLS ADJOINING COMMON AREAS
- TO ONE (1) CENTIMETRE INSIDE OF THE OUTSIDE FACE OF EXTERIOR WALLS
- TO FACE OF CONCRETE WALLS WHERE STRATA LOTS ADJOIN CORE WALLS (IE ELEVATOR, STAIRWELL).

ALL ANGLES ARE 90° OR 45° UNLESS OTHERWISE NOTED

LEGEND

- SL — STRATA LOT
- ELEC — DENOTES ELECTRICAL
- MECH — DENOTES MECHANICAL
- ⊙ — COMMON PROPERTY
- ③ — DENOTES LIMITED COMMON PROPERTY FOR STRATA LOT 31 (TYPICAL)

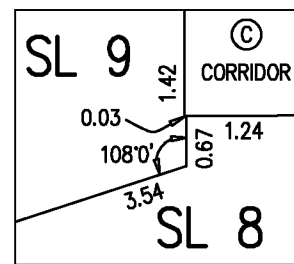

DETAIL
NOT TO SCALE

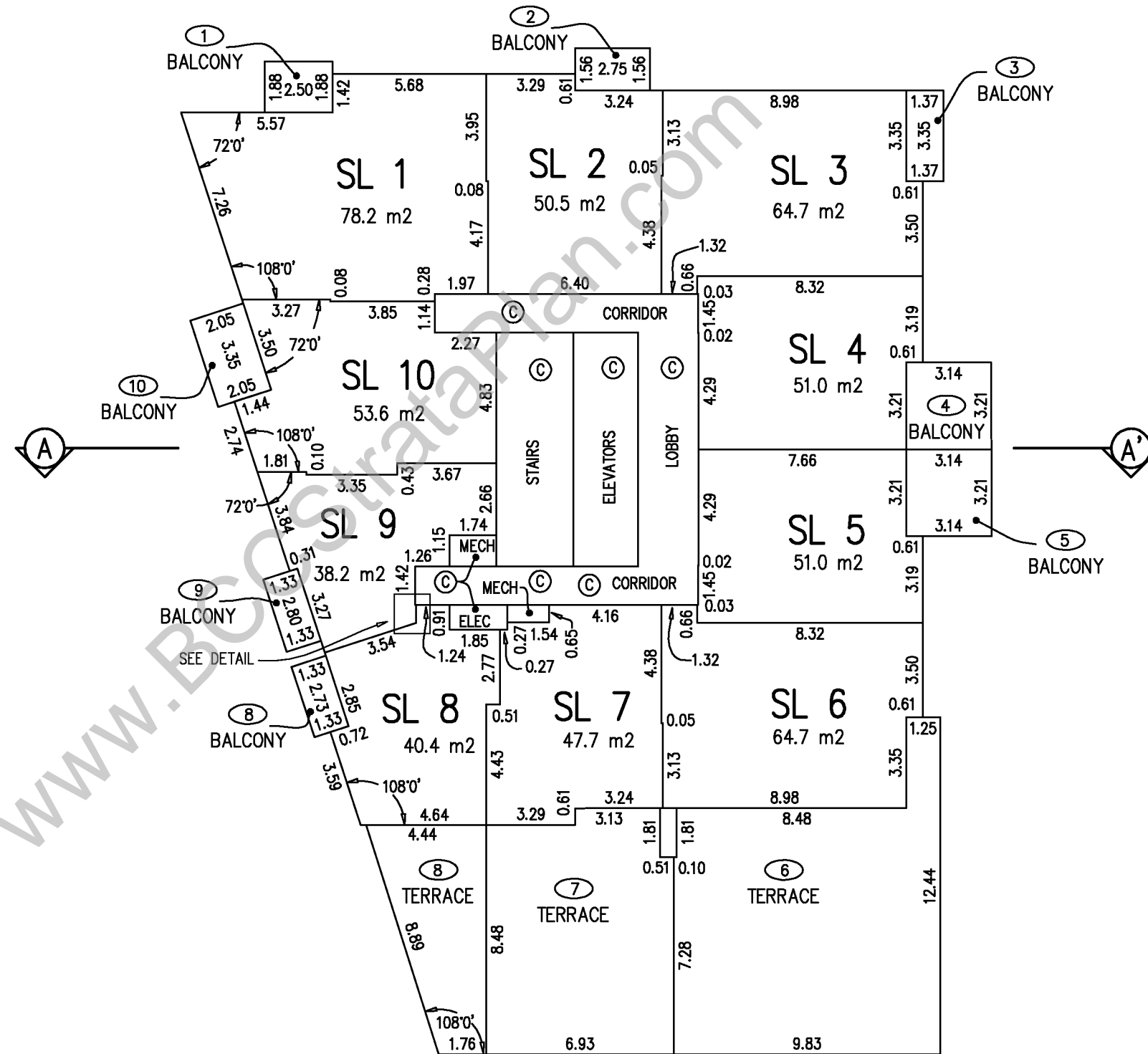

JAMES G. SHAW, BCLS, CLS
DATE: FEBRUARY 25, 2013
McELHANNEY ASSOCIATES
LAND SURVEYING LTD.
FILE: 2112-07909-24

BUILDING 1 LEVEL 3

SHEET 14 OF 48 SHEETS
STRATA PLAN EPS1133

SCALE 1 : 200



ALL DISTANCES ARE IN METRES AND DECIMALS THEREOF
THE INTENDED PLOT SIZE OF THIS PLAN IS 280mm IN WIDTH
BY 432mm IN HEIGHT (B SIZE) WHEN PLOTTED AT A SCALE OF 1:200

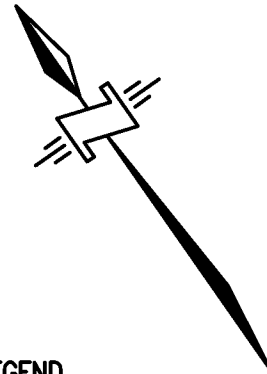

METHOD OF MEASUREMENT:
-TO CENTRELINE OF ALL DEMISING WALLS BETWEEN STRATA LOTS AND ALL STRATA LOT WALLS ADJOINING COMMON AREAS
-TO ONE (1) CENTIMETRE INSIDE OF THE OUTSIDE FACE OF EXTERIOR WALLS
-TO FACE OF CONCRETE WALLS WHERE STRATA LOTS ADJOIN CORE WALLS (IE ELEVATOR, STAIRWELL).

ALL ANGLES ARE 90° OR 45° UNLESS OTHERWISE NOTED

LEGEND

- SL — STRATA LOT
- ELEC — DENOTES ELECTRICAL
- MECH — DENOTES MECHANICAL
- Ⓢ — COMMON PROPERTY
- Ⓢ1 — DENOTES LIMITED COMMON PROPERTY FOR STRATA LOT 31 (TYPICAL)

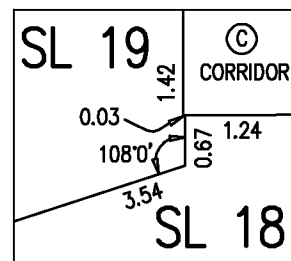

DETAIL
NOT TO SCALE

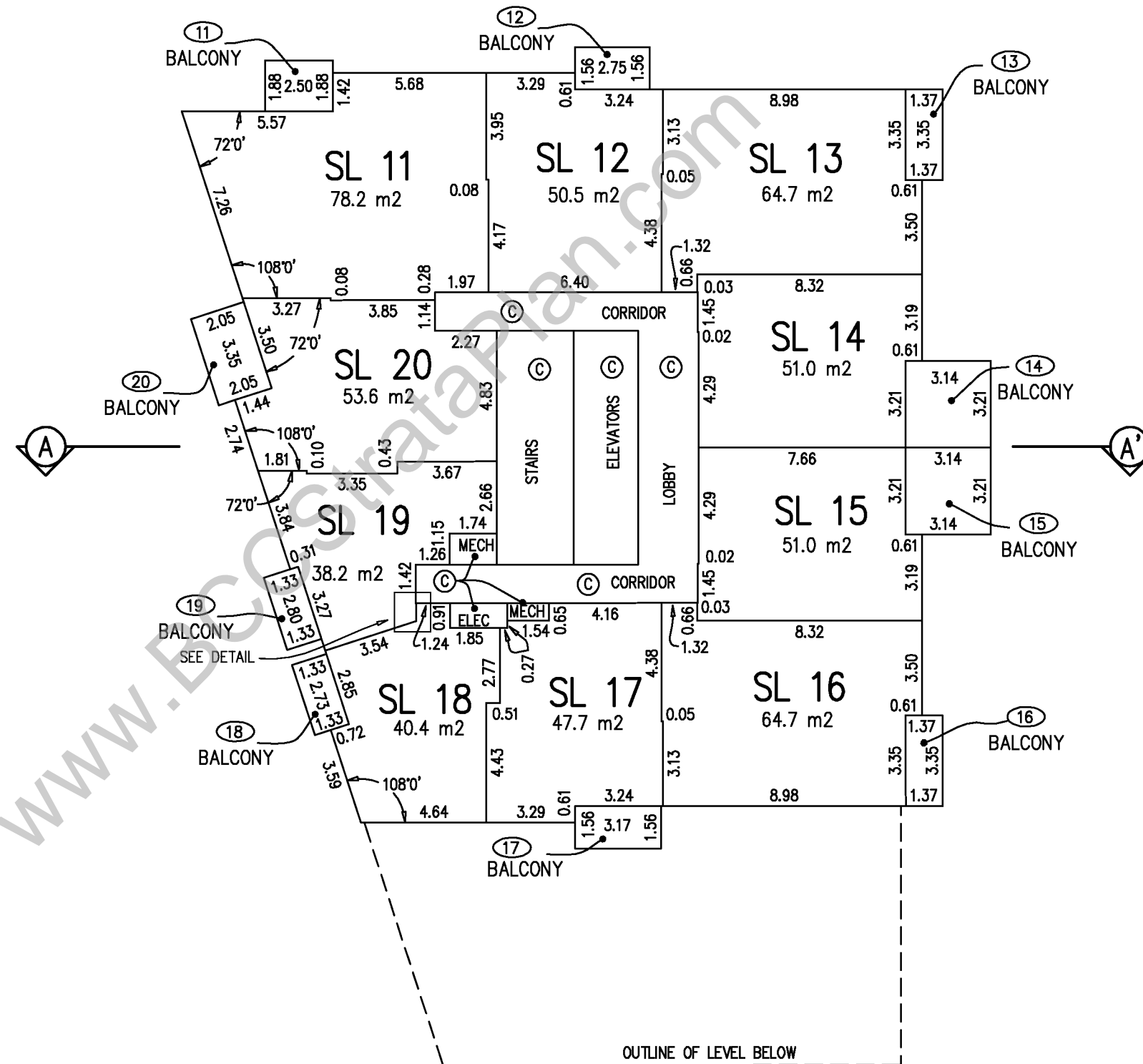

JAMES G. SHAW, BCLS, CLS
DATE: FEBRUARY 25, 2013
McELHANNEY ASSOCIATES
LAND SURVEYING LTD.
FILE: 2112-07909-24

BUILDING 1 LEVEL 4

SHEET 15 OF 48 SHEETS
STRATA PLAN EPS1133

SCALE 1 : 200

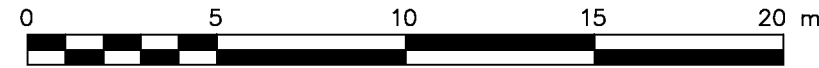

ALL DISTANCES ARE IN METRES AND DECIMALS THEREOF
THE INTENDED PLOT SIZE OF THIS PLAN IS 280mm IN WIDTH
BY 432mm IN HEIGHT (B SIZE) WHEN PLOTTED AT A SCALE OF 1:200

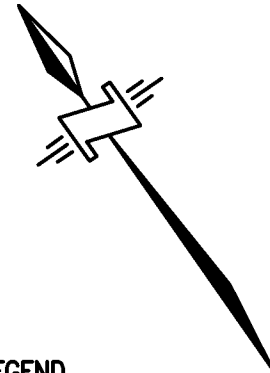

METHOD OF MEASUREMENT:
-TO CENTRELINE OF ALL DEMISING WALLS BETWEEN STRATA LOTS AND ALL STRATA LOT WALLS ADJOINING COMMON AREAS
-TO ONE (1) CENTIMETRE INSIDE OF THE OUTSIDE FACE OF EXTERIOR WALLS
-TO FACE OF CONCRETE WALLS WHERE STRATA LOTS ADJOIN CORE WALLS (IE ELEVATOR, STAIRWELL).

ALL ANGLES ARE 90° OR 45° UNLESS OTHERWISE NOTED

LEGEND

- SL — STRATA LOT
- ELEC — DENOTES ELECTRICAL
- MECH — DENOTES MECHANICAL
- ⊙ — COMMON PROPERTY
- ⊙31 — DENOTES LIMITED COMMON PROPERTY FOR STRATA LOT 31 (TYPICAL)

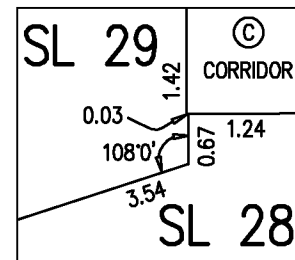

DETAIL
NOT TO SCALE

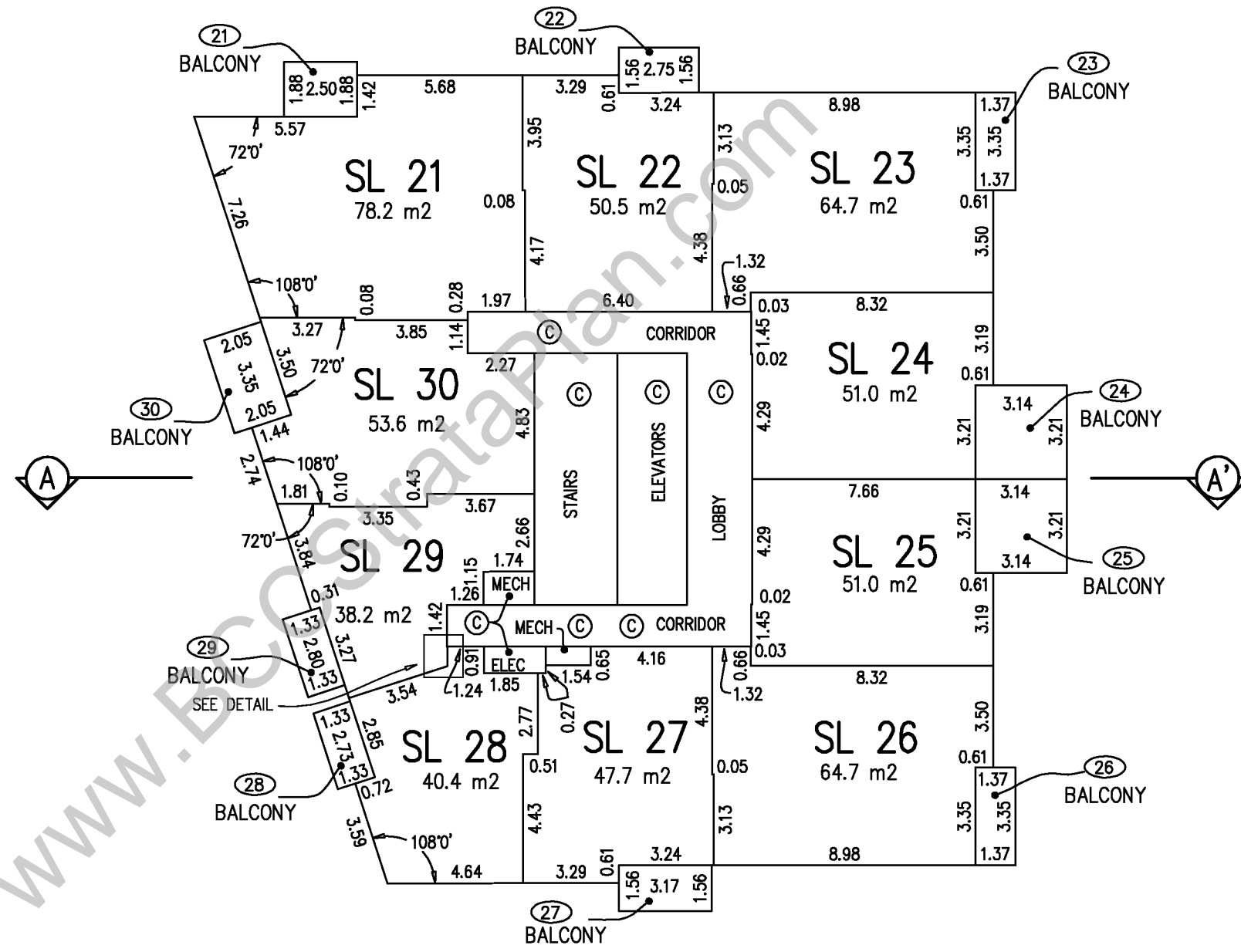

JAMES G. SHAW, BCLS, CLS
DATE: FEBRUARY 25, 2013
McELHANNEY ASSOCIATES
LAND SURVEYING LTD.
FILE: 2112-07909-24

BUILDING 1 LEVEL 5

SHEET 16 OF 48 SHEETS
STRATA PLAN EPS1133

SCALE 1 : 200

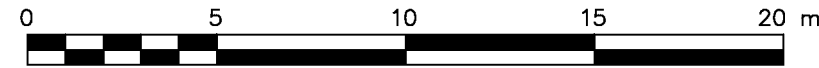

ALL DISTANCES ARE IN METRES AND DECIMALS THEREOF
THE INTENDED PLOT SIZE OF THIS PLAN IS 280mm IN WIDTH
BY 432mm IN HEIGHT (B SIZE) WHEN PLOTTED AT A SCALE OF 1:200

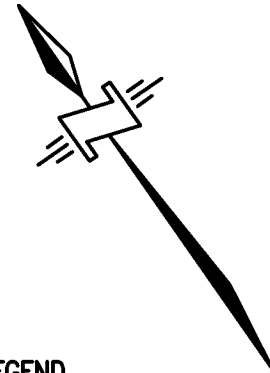

METHOD OF MEASUREMENT:
-TO CENTRELINE OF ALL DEMISING WALLS BETWEEN STRATA LOTS AND ALL STRATA LOT WALLS ADJOINING COMMON AREAS
-TO ONE (1) CENTIMETRE INSIDE OF THE OUTSIDE FACE OF EXTERIOR WALLS
-TO FACE OF CONCRETE WALLS WHERE STRATA LOTS ADJOIN CORE WALLS (IE ELEVATOR, STAIRWELL).

ALL ANGLES ARE 90° OR 45° UNLESS OTHERWISE NOTED

LEGEND

- SL — STRATA LOT
- ELEC — DENOTES ELECTRICAL
- MECH — DENOTES MECHANICAL
- ⊙ — COMMON PROPERTY
- Ⓢ — DENOTES LIMITED COMMON PROPERTY FOR STRATA LOT 31 (TYPICAL)

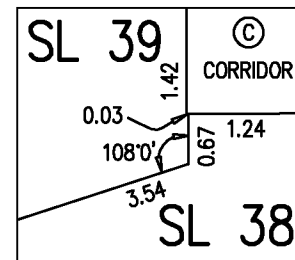

DETAIL
NOT TO SCALE

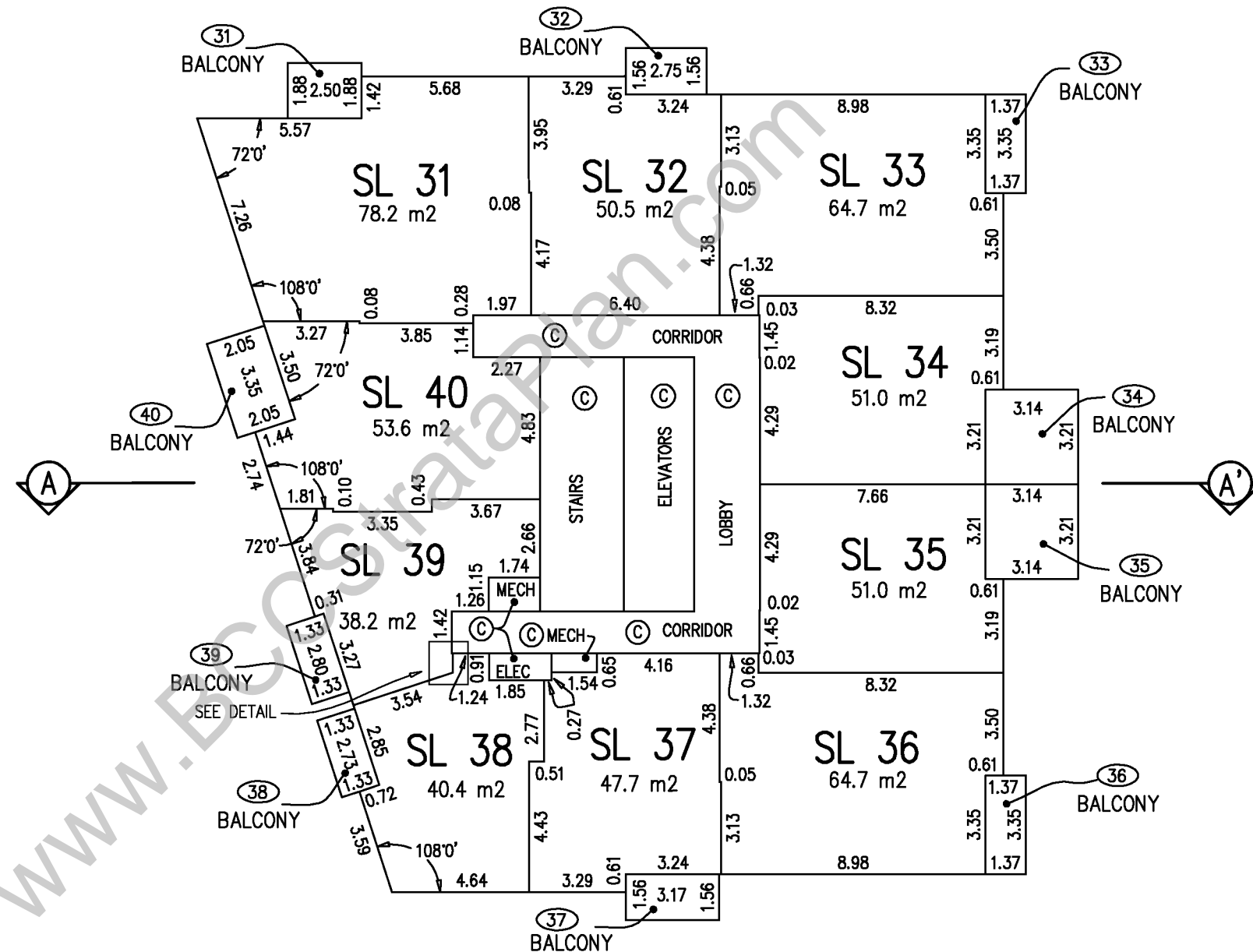

JAMES G. SHAW, BCLS, CLS
DATE: FEBRUARY 25, 2013
McELHANNEY ASSOCIATES
LAND SURVEYING LTD.
FILE: 2112-07909-24

BUILDING 1 LEVEL 6

SHEET 17 OF 48 SHEETS
STRATA PLAN EPS1133

SCALE 1 : 200

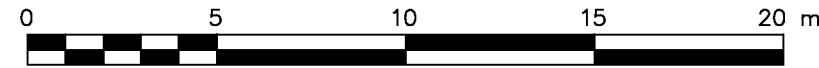

ALL DISTANCES ARE IN METRES AND DECIMALS THEREOF
THE INTENDED PLOT SIZE OF THIS PLAN IS 280mm IN WIDTH
BY 432mm IN HEIGHT (B SIZE) WHEN PLOTTED AT A SCALE OF 1:200

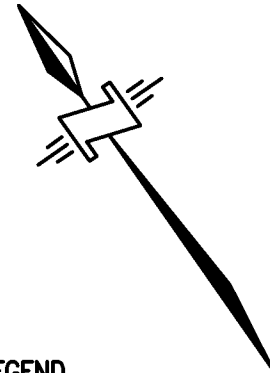

METHOD OF MEASUREMENT:
-TO CENTRELINE OF ALL DEMISING WALLS BETWEEN STRATA LOTS AND ALL STRATA LOT WALLS ADJOINING COMMON AREAS
-TO ONE (1) CENTIMETRE INSIDE OF THE OUTSIDE FACE OF EXTERIOR WALLS
-TO FACE OF CONCRETE WALLS WHERE STRATA LOTS ADJOIN CORE WALLS (IE ELEVATOR, STAIRWELL).

ALL ANGLES ARE 90° OR 45° UNLESS OTHERWISE NOTED

LEGEND

- SL — STRATA LOT
- ELEC — DENOTES ELECTRICAL
- MECH — DENOTES MECHANICAL
- ⊙ — COMMON PROPERTY
- Ⓢ — DENOTES LIMITED COMMON PROPERTY FOR STRATA LOT 31 (TYPICAL)

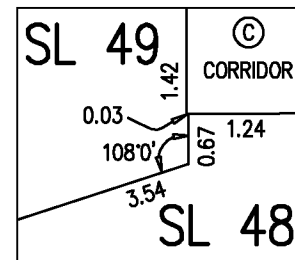

DETAIL
NOT TO SCALE

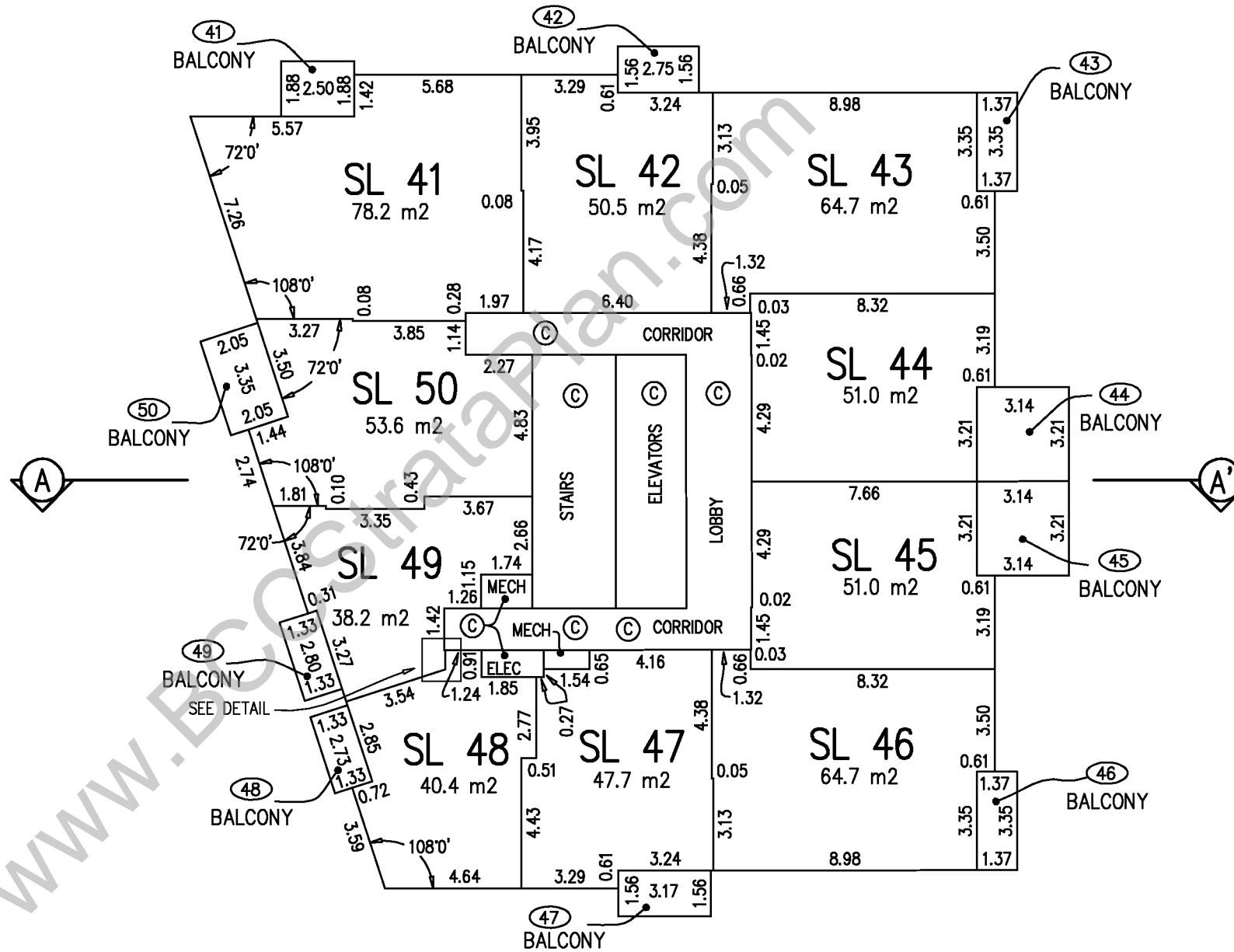

JAMES G. SHAW, BCLS, CLS
DATE: FEBRUARY 25, 2013
McELHANNEY ASSOCIATES
LAND SURVEYING LTD.
FILE: 2112-07909-24

BUILDING 1 LEVEL 7

SHEET 18 OF 48 SHEETS
STRATA PLAN EPS1133

SCALE 1 : 200

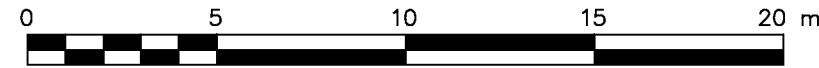

ALL DISTANCES ARE IN METRES AND DECIMALS THEREOF
THE INTENDED PLOT SIZE OF THIS PLAN IS 280mm IN WIDTH
BY 432mm IN HEIGHT (B SIZE) WHEN PLOTTED AT A SCALE OF 1:200

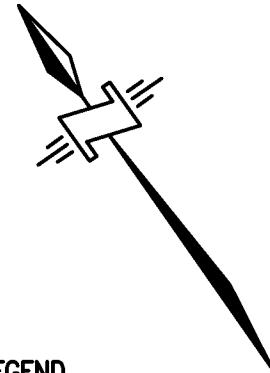

METHOD OF MEASUREMENT:
-TO CENTRELINE OF ALL DEMISING WALLS BETWEEN STRATA LOTS AND ALL STRATA LOT WALLS ADJOINING COMMON AREAS
-TO ONE (1) CENTIMETRE INSIDE OF THE OUTSIDE FACE OF EXTERIOR WALLS
-TO FACE OF CONCRETE WALLS WHERE STRATA LOTS ADJOIN CORE WALLS (IE ELEVATOR, STAIRWELL).

ALL ANGLES ARE 90° OR 45° UNLESS OTHERWISE NOTED

LEGEND

- SL — STRATA LOT
- ELEC — DENOTES ELECTRICAL
- MECH — DENOTES MECHANICAL
- ⊙ — COMMON PROPERTY
- Ⓢ — DENOTES LIMITED COMMON PROPERTY FOR STRATA LOT 31 (TYPICAL)

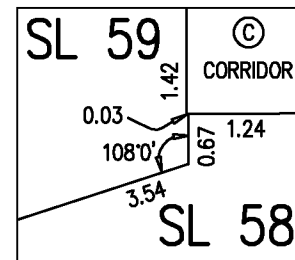

DETAIL
NOT TO SCALE

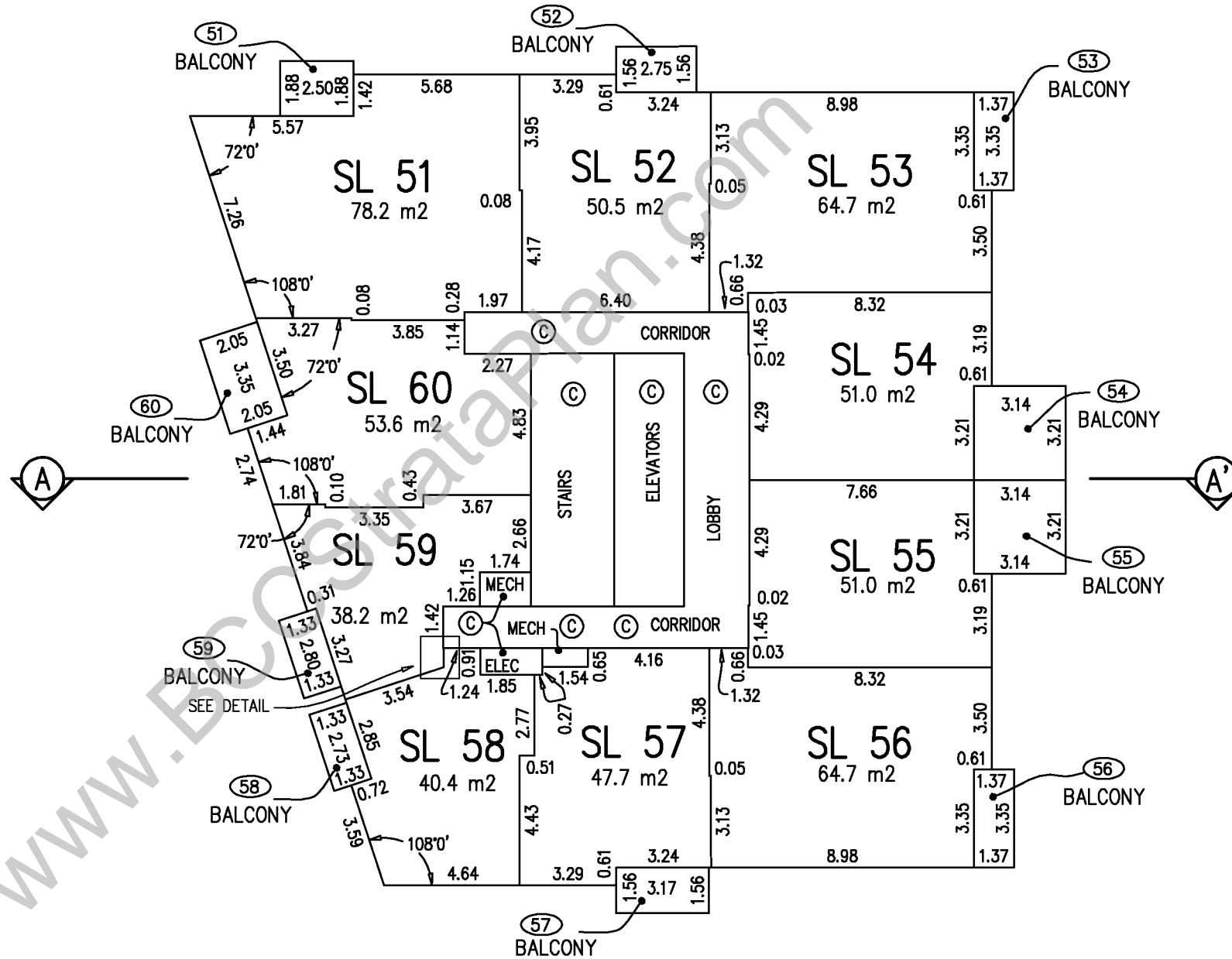

JAMES G. SHAW, BCLS, CLS
DATE: FEBRUARY 25, 2013
McELHANNEY ASSOCIATES
LAND SURVEYING LTD.
FILE: 2112-07909-24

BUILDING 1 LEVEL 8

SHEET 19 OF 48 SHEETS
STRATA PLAN EPS1133

SCALE 1 : 200

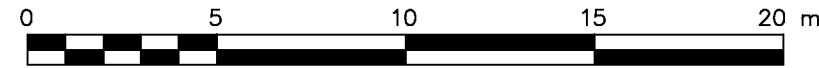

ALL DISTANCES ARE IN METRES AND DECIMALS THEREOF
THE INTENDED PLOT SIZE OF THIS PLAN IS 280mm IN WIDTH
BY 432mm IN HEIGHT (B SIZE) WHEN PLOTTED AT A SCALE OF 1:200

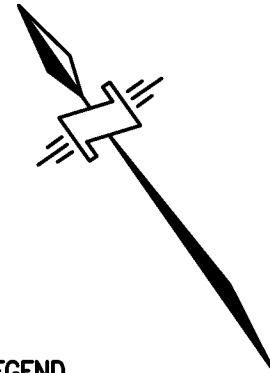

METHOD OF MEASUREMENT:

- TO CENTRELINE OF ALL DEMISING WALLS BETWEEN STRATA LOTS AND ALL STRATA LOT WALLS ADJOINING COMMON AREAS
- TO ONE (1) CENTIMETRE INSIDE OF THE OUTSIDE FACE OF EXTERIOR WALLS
- TO FACE OF CONCRETE WALLS WHERE STRATA LOTS ADJOIN CORE WALLS (IE ELEVATOR, STAIRWELL).

ALL ANGLES ARE 90° OR 45° UNLESS OTHERWISE NOTED

LEGEND

- SL — STRATA LOT
- ELEC — DENOTES ELECTRICAL
- MECH — DENOTES MECHANICAL
- ⊙ — COMMON PROPERTY
- ⊙31 — DENOTES LIMITED COMMON PROPERTY FOR STRATA LOT 31 (TYPICAL)

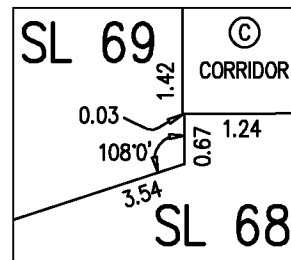

DETAIL
NOT TO SCALE

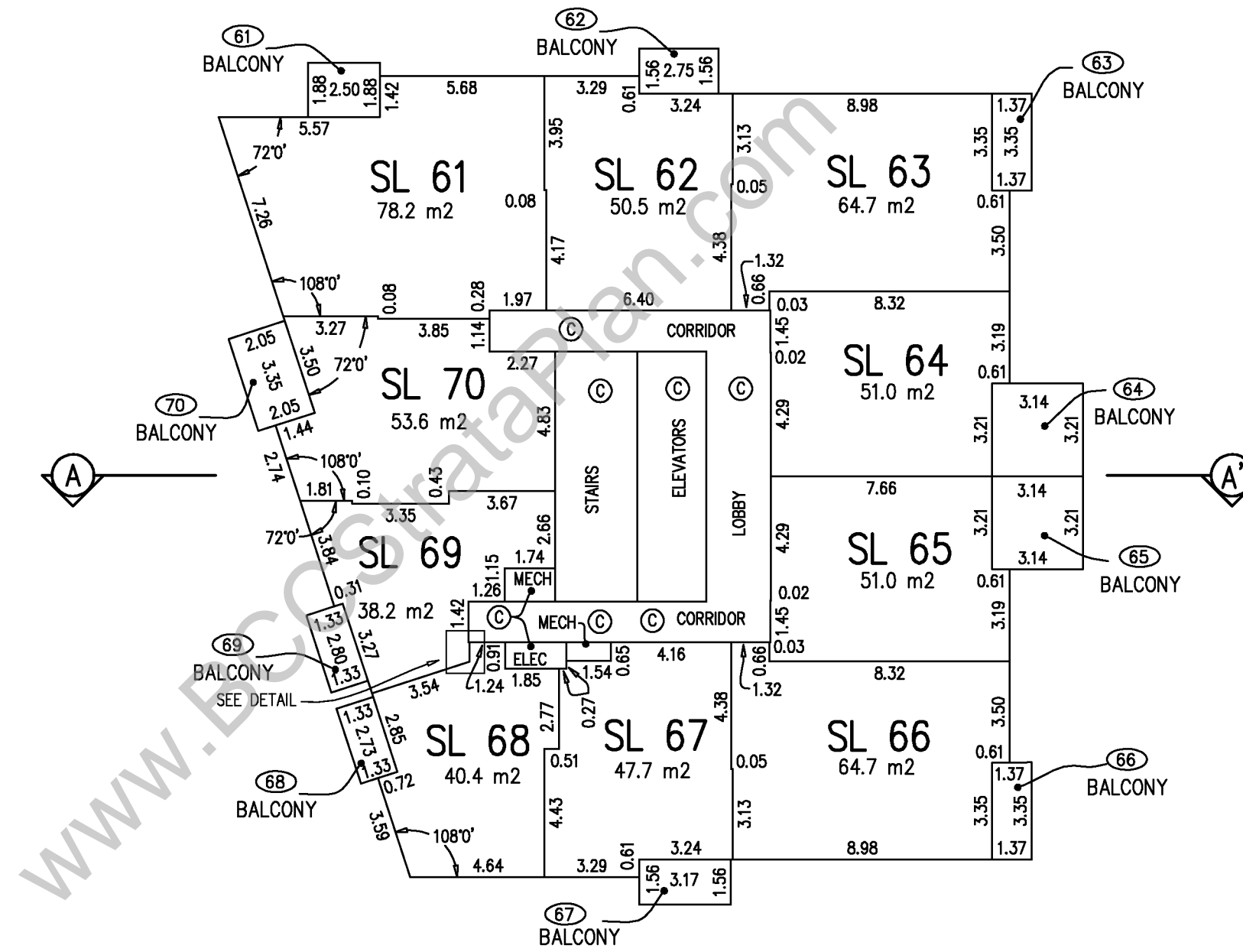

JAMES G. SHAW, BCLS, CLS
DATE: FEBRUARY 25, 2013
McELHANNEY ASSOCIATES
LAND SURVEYING LTD.
FILE: 2112-07909-24

BUILDING 1 LEVEL 9

SHEET 20 OF 48 SHEETS
STRATA PLAN EPS1133

SCALE 1 : 200

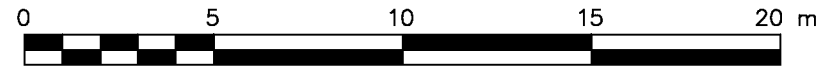

ALL DISTANCES ARE IN METRES AND DECIMALS THEREOF
THE INTENDED PLOT SIZE OF THIS PLAN IS 280mm IN WIDTH
BY 432mm IN HEIGHT (B SIZE) WHEN PLOTTED AT A SCALE OF 1:200

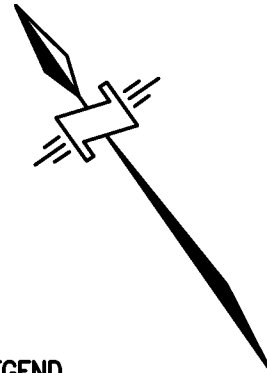

METHOD OF MEASUREMENT:
-TO CENTRELINE OF ALL DEMISING WALLS BETWEEN STRATA LOTS AND ALL STRATA LOT WALLS ADJOINING COMMON AREAS
-TO ONE (1) CENTIMETRE INSIDE OF THE OUTSIDE FACE OF EXTERIOR WALLS
-TO FACE OF CONCRETE WALLS WHERE STRATA LOTS ADJOIN CORE WALLS (IE ELEVATOR, STAIRWELL).

ALL ANGLES ARE 90° OR 45° UNLESS OTHERWISE NOTED

LEGEND

- SL — STRATA LOT
- ELEC — DENOTES ELECTRICAL
- MECH — DENOTES MECHANICAL
- ⊙ — COMMON PROPERTY
- Ⓢ — DENOTES LIMITED COMMON PROPERTY FOR STRATA LOT 31 (TYPICAL)

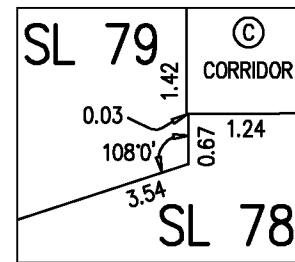

DETAIL
NOT TO SCALE

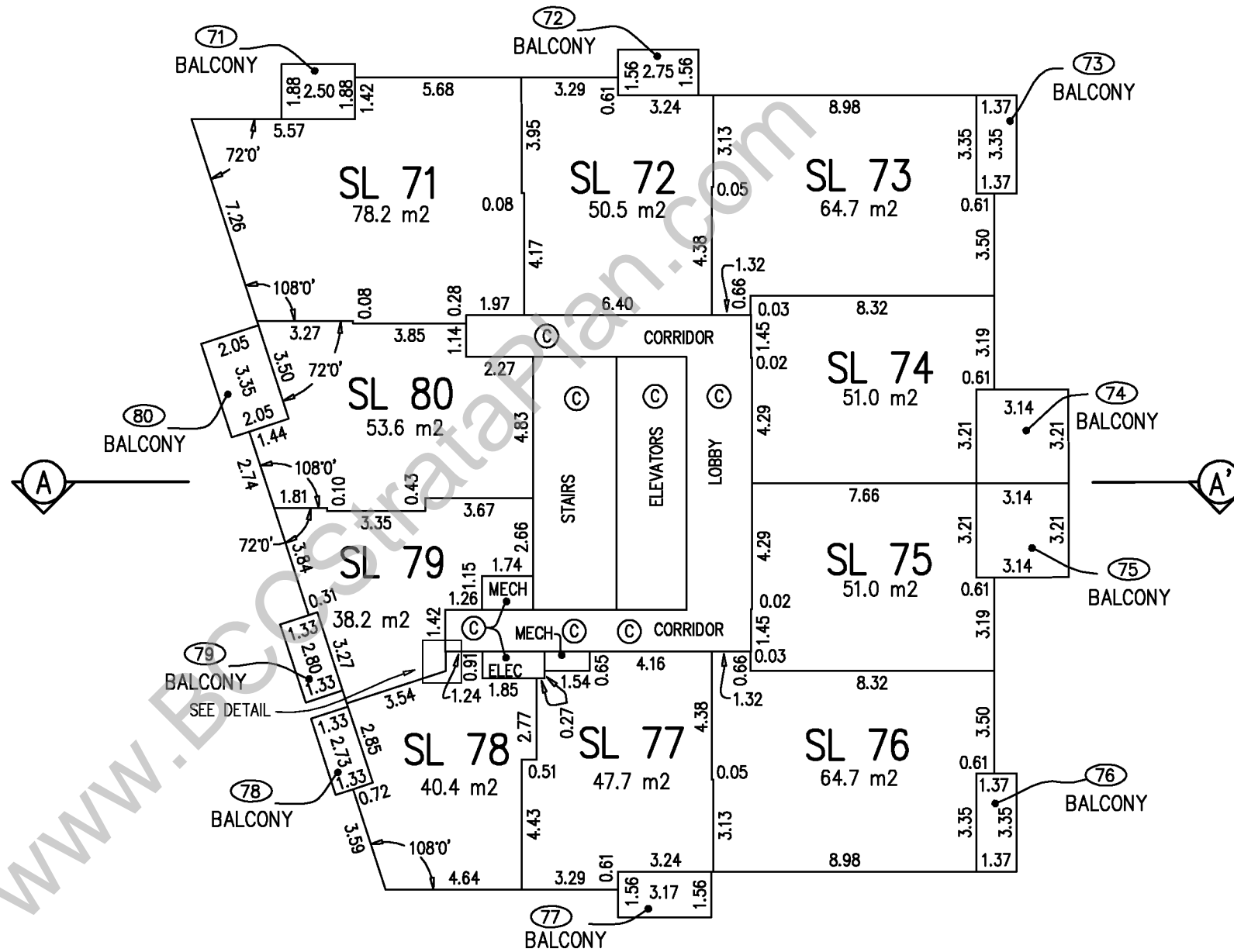

JAMES G. SHAW, BCLS, CLS
DATE: FEBRUARY 25, 2013
McELHANNEY ASSOCIATES
LAND SURVEYING LTD.
FILE: 2112-07909-24

BUILDING 1 LEVEL 10

SHEET 21 OF 48 SHEETS
STRATA PLAN EPS1133

SCALE 1 : 200

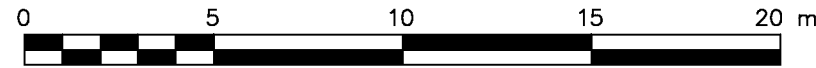

ALL DISTANCES ARE IN METRES AND DECIMALS THEREOF
THE INTENDED PLOT SIZE OF THIS PLAN IS 280mm IN WIDTH
BY 432mm IN HEIGHT (B SIZE) WHEN PLOTTED AT A SCALE OF 1:200

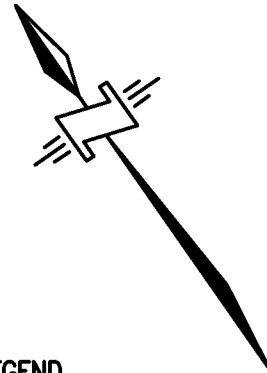

METHOD OF MEASUREMENT:

- TO CENTRELINE OF ALL DEMISING WALLS BETWEEN STRATA LOTS AND ALL STRATA LOT WALLS ADJOINING COMMON AREAS
- TO ONE (1) CENTIMETRE INSIDE OF THE OUTSIDE FACE OF EXTERIOR WALLS
- TO FACE OF CONCRETE WALLS WHERE STRATA LOTS ADJOIN CORE WALLS (IE ELEVATOR, STAIRWELL).

ALL ANGLES ARE 90° OR 45° UNLESS OTHERWISE NOTED

LEGEND

- SL — STRATA LOT
- ELEC — DENOTES ELECTRICAL
- MECH — DENOTES MECHANICAL
- ⊙ — COMMON PROPERTY
- ⊙31 — DENOTES LIMITED COMMON PROPERTY FOR STRATA LOT 31 (TYPICAL)

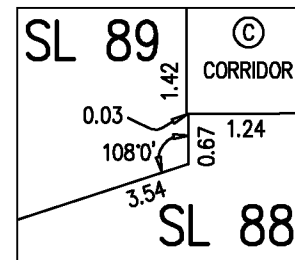

DETAIL
NOT TO SCALE

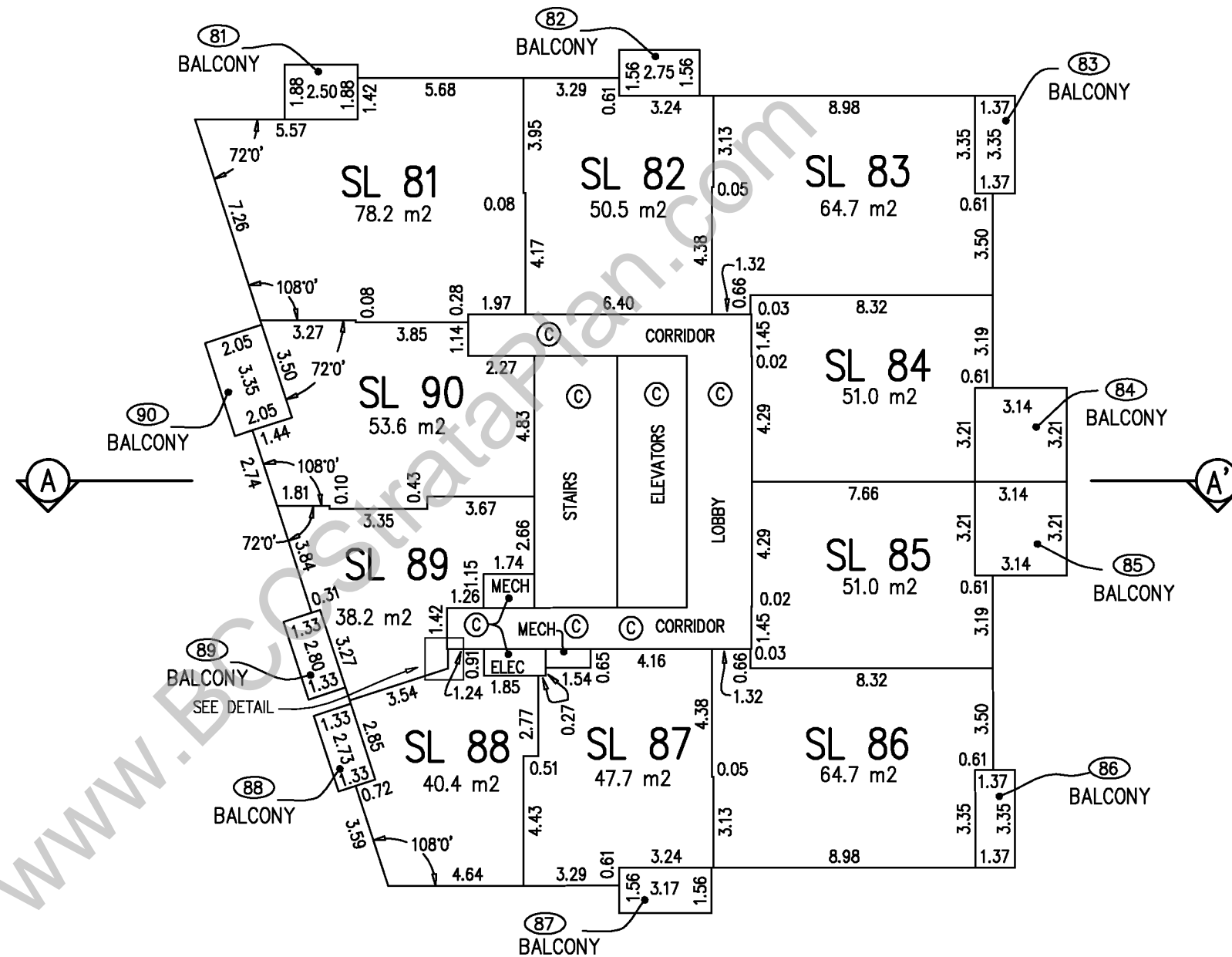

JAMES G. SHAW, BCLS, CLS
DATE: FEBRUARY 25, 2013
McELHANNEY ASSOCIATES
LAND SURVEYING LTD.
FILE: 2112-07909-24

BUILDING 1 LEVEL 11

SHEET 22 OF 48 SHEETS
STRATA PLAN EPS1133

SCALE 1 : 200



ALL DISTANCES ARE IN METRES AND DECIMALS THEREOF
THE INTENDED PLOT SIZE OF THIS PLAN IS 280mm IN WIDTH
BY 432mm IN HEIGHT (B SIZE) WHEN PLOTTED AT A SCALE OF 1:200

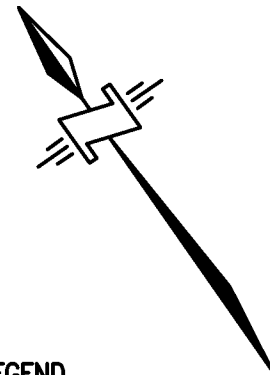

METHOD OF MEASUREMENT:
-TO CENTRELINE OF ALL DEMISING WALLS BETWEEN STRATA LOTS AND ALL STRATA LOT WALLS ADJOINING COMMON AREAS
-TO ONE (1) CENTIMETRE INSIDE OF THE OUTSIDE FACE OF EXTERIOR WALLS
-TO FACE OF CONCRETE WALLS WHERE STRATA LOTS ADJOIN CORE WALLS (IE ELEVATOR, STAIRWELL).

ALL ANGLES ARE 90° OR 45° UNLESS OTHERWISE NOTED

LEGEND

- SL — STRATA LOT
- ELEC — DENOTES ELECTRICAL
- MECH — DENOTES MECHANICAL
- ⊙ — COMMON PROPERTY
- ③① — DENOTES LIMITED COMMON PROPERTY FOR STRATA LOT 31 (TYPICAL)

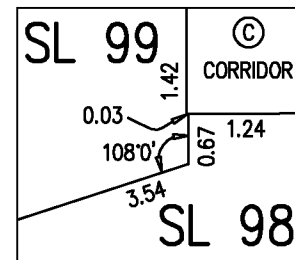

DETAIL
NOT TO SCALE

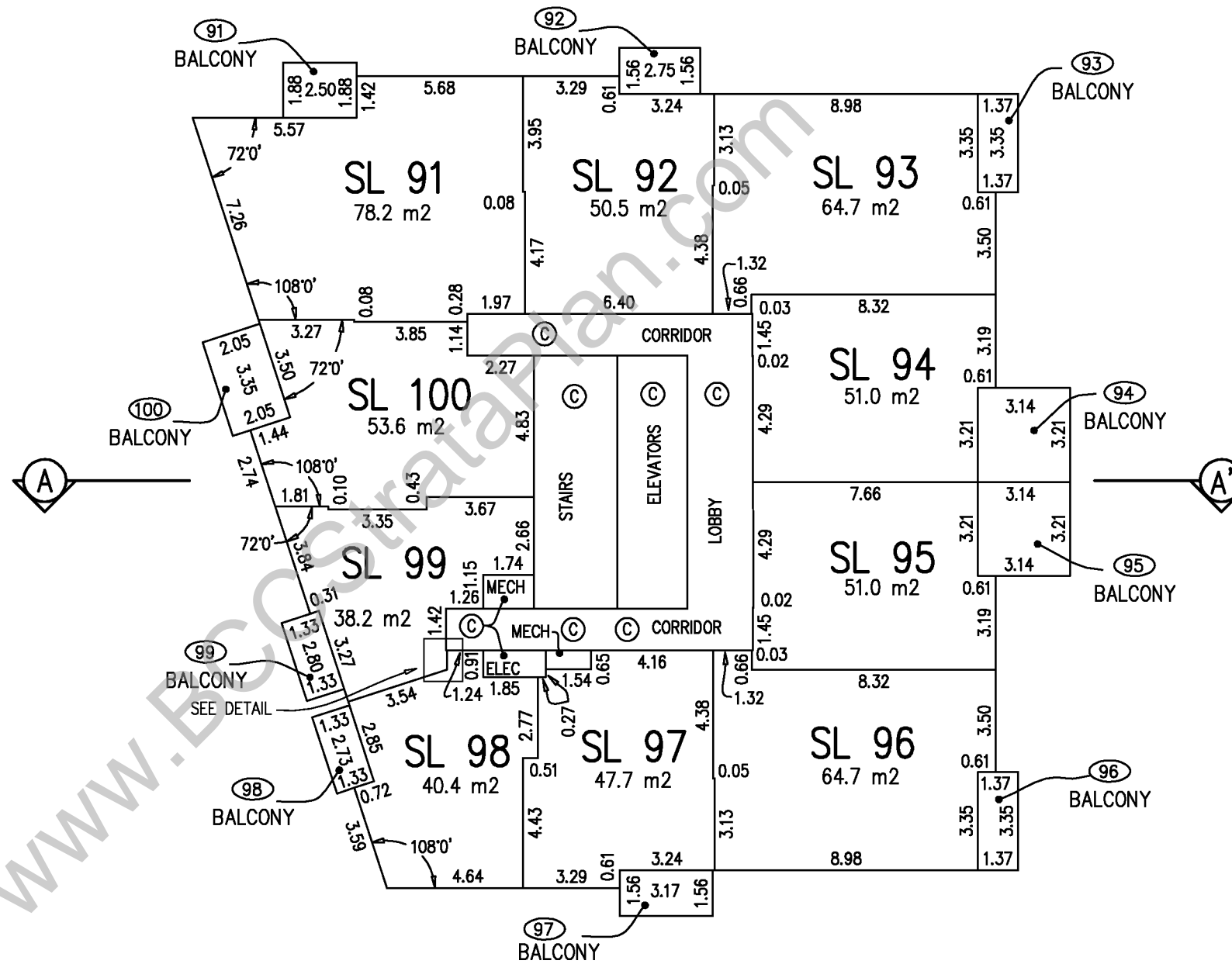

JAMES G. SHAW, BCLS, CLS
DATE: FEBRUARY 25, 2013
McELHANNEY ASSOCIATES
LAND SURVEYING LTD.
FILE: 2112-07909-24

BUILDING 1 LEVEL 12

SHEET 23 OF 48 SHEETS
STRATA PLAN EPS1133

SCALE 1 : 200



ALL DISTANCES ARE IN METRES AND DECIMALS THEREOF
THE INTENDED PLOT SIZE OF THIS PLAN IS 280mm IN WIDTH
BY 432mm IN HEIGHT (B SIZE) WHEN PLOTTED AT A SCALE OF 1:200

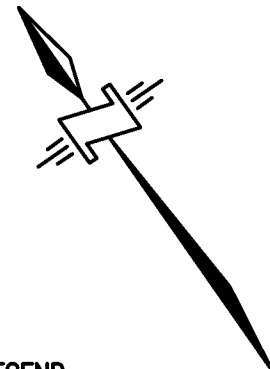

METHOD OF MEASUREMENT:
-TO CENTRELINE OF ALL DEMISING WALLS BETWEEN STRATA LOTS AND ALL STRATA LOT WALLS ADJOINING COMMON AREAS
-TO ONE (1) CENTIMETRE INSIDE OF THE OUTSIDE FACE OF EXTERIOR WALLS
-TO FACE OF CONCRETE WALLS WHERE STRATA LOTS ADJOIN CORE WALLS (IE ELEVATOR, STAIRWELL).

LEGEND

- SL — STRATA LOT
 - ELEC — DENOTES ELECTRICAL
 - MECH — DENOTES MECHANICAL
 - ⊙ — COMMON PROPERTY
 - Ⓢ — DENOTES LIMITED COMMON PROPERTY FOR STRATA LOT 31 (TYPICAL)
- ALL ANGLES ARE 90° OR 45° UNLESS OTHERWISE NOTED

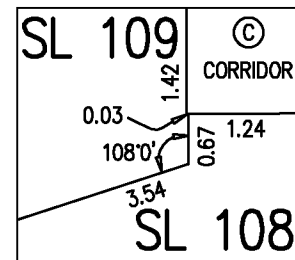

DETAIL
NOT TO SCALE

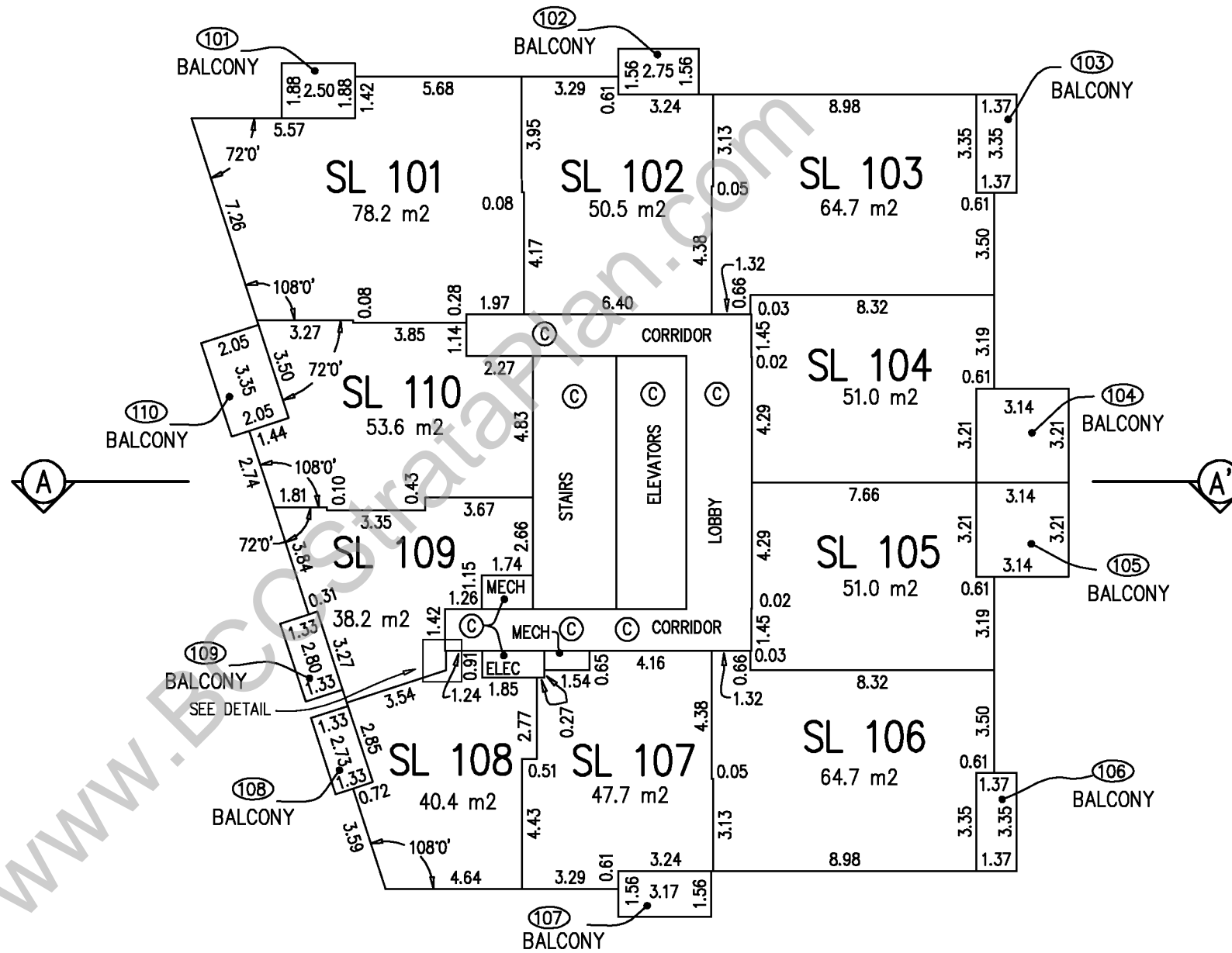

JAMES G. SHAW, BCLS, CLS
DATE: FEBRUARY 25, 2013
McELHANNEY ASSOCIATES
LAND SURVEYING LTD.
FILE: 2112-07909-24

BUILDING 1 LEVEL 13

SHEET 24 OF 48 SHEETS
STRATA PLAN EPS1133

SCALE 1 : 200



ALL DISTANCES ARE IN METRES AND DECIMALS THEREOF
THE INTENDED PLOT SIZE OF THIS PLAN IS 280mm IN WIDTH
BY 432mm IN HEIGHT (B SIZE) WHEN PLOTTED AT A SCALE OF 1:200

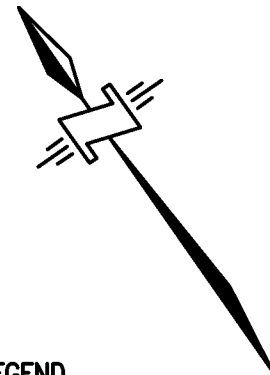

METHOD OF MEASUREMENT:
-TO CENTRELINE OF ALL DEMISING WALLS BETWEEN STRATA LOTS AND ALL STRATA LOT WALLS ADJOINING COMMON AREAS
-TO ONE (1) CENTIMETRE INSIDE OF THE OUTSIDE FACE OF EXTERIOR WALLS
-TO FACE OF CONCRETE WALLS WHERE STRATA LOTS ADJOIN CORE WALLS (IE ELEVATOR, STAIRWELL).

ALL ANGLES ARE 90° OR 45° UNLESS OTHERWISE NOTED

LEGEND

- SL — STRATA LOT
- ELEC — DENOTES ELECTRICAL
- MECH — DENOTES MECHANICAL
- ⊙ — COMMON PROPERTY
- Ⓢ — DENOTES LIMITED COMMON PROPERTY FOR STRATA LOT 31 (TYPICAL)

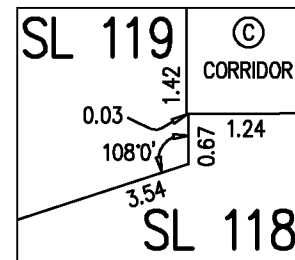

DETAIL
NOT TO SCALE

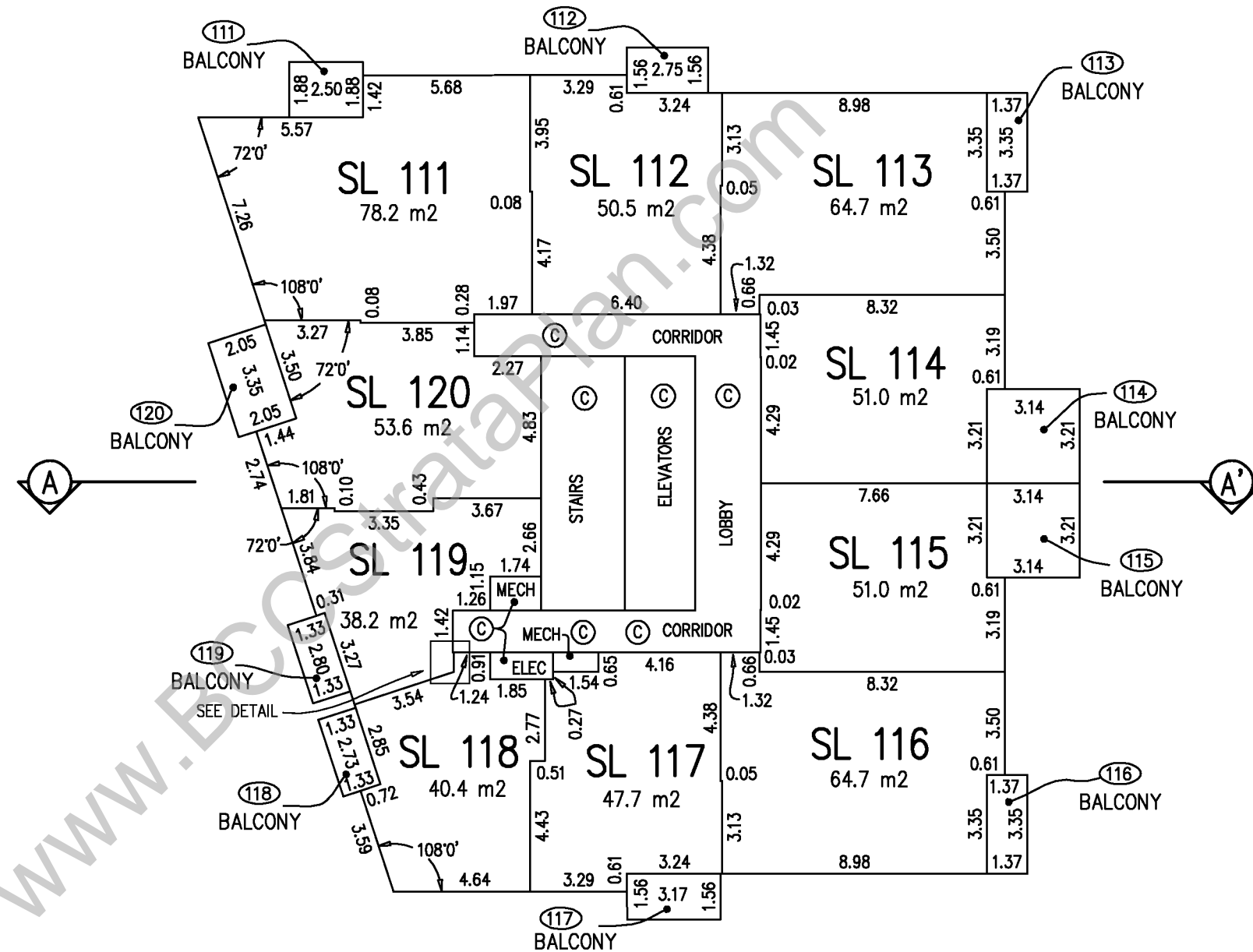

JAMES G. SHAW, BCLS, CLS
DATE: FEBRUARY 25, 2013
McELHANNEY ASSOCIATES
LAND SURVEYING LTD.
FILE: 2112-07909-24

BUILDING 1 LEVEL 14

SHEET 25 OF 48 SHEETS
STRATA PLAN EPS1133

SCALE 1 : 200

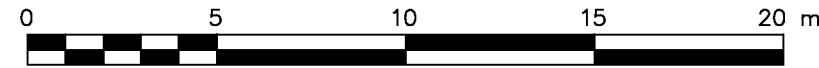

ALL DISTANCES ARE IN METRES AND DECIMALS THEREOF
THE INTENDED PLOT SIZE OF THIS PLAN IS 280mm IN WIDTH
BY 432mm IN HEIGHT (B SIZE) WHEN PLOTTED AT A SCALE OF 1:200

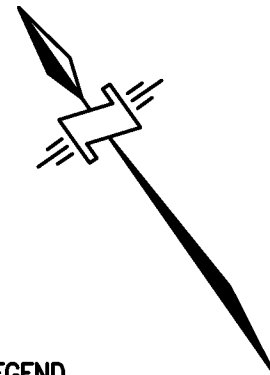

METHOD OF MEASUREMENT:
-TO CENTRELINE OF ALL DEMISING WALLS BETWEEN STRATA LOTS AND ALL STRATA LOT WALLS ADJOINING COMMON AREAS
-TO ONE (1) CENTIMETRE INSIDE OF THE OUTSIDE FACE OF EXTERIOR WALLS
-TO FACE OF CONCRETE WALLS WHERE STRATA LOTS ADJOIN CORE WALLS (IE ELEVATOR, STAIRWELL).

ALL ANGLES ARE 90° OR 45° UNLESS OTHERWISE NOTED

LEGEND

- SL — STRATA LOT
- ELEC — DENOTES ELECTRICAL
- MECH — DENOTES MECHANICAL
- ⊙ — COMMON PROPERTY
- Ⓢ — DENOTES LIMITED COMMON PROPERTY FOR STRATA LOT 31 (TYPICAL)

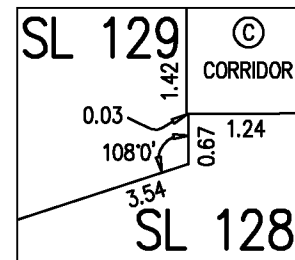

DETAIL
NOT TO SCALE

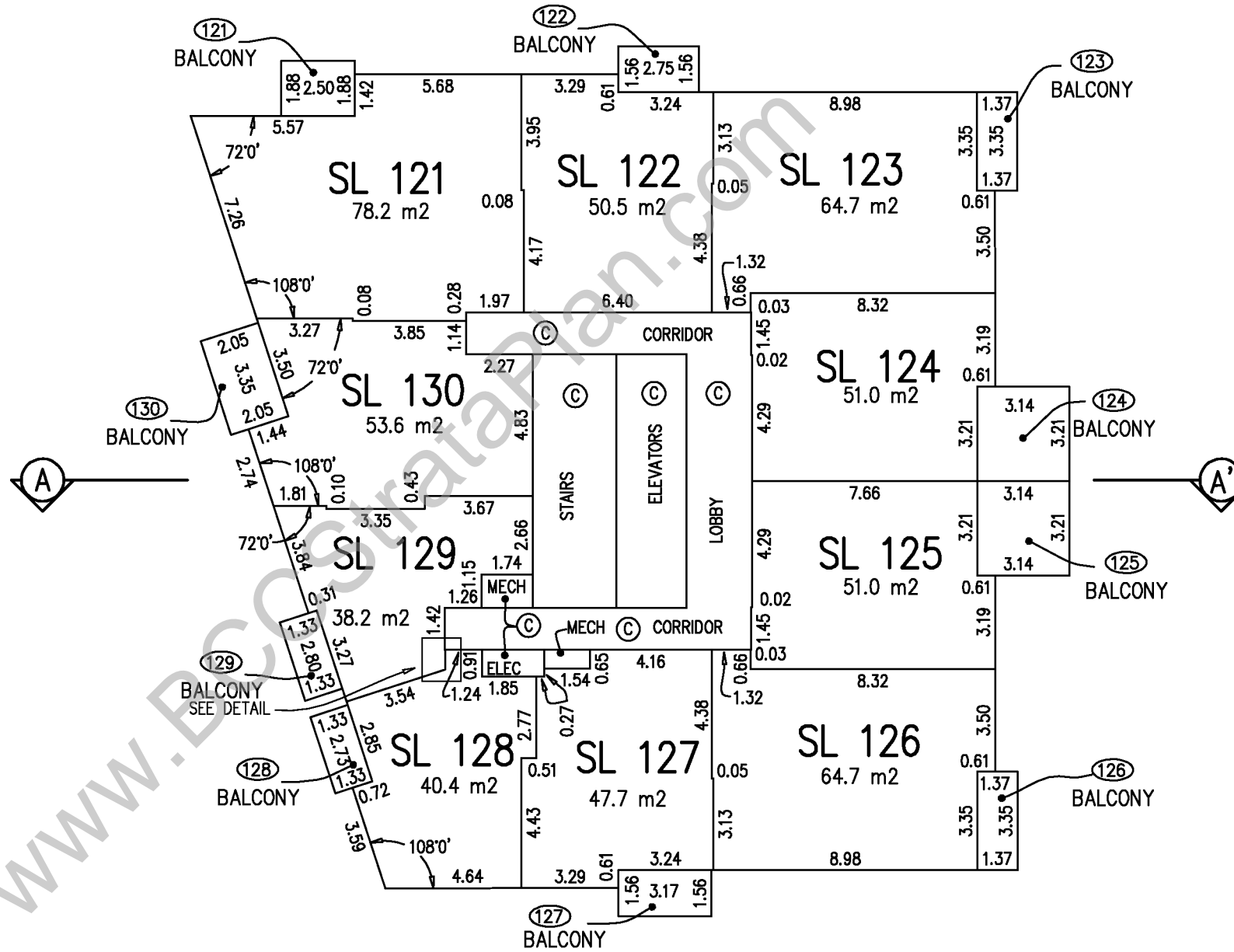

JAMES G. SHAW, BCLS, CLS
DATE: FEBRUARY 25, 2013
McELHANNEY ASSOCIATES
LAND SURVEYING LTD.
FILE: 2112-07909-24

BUILDING 1 LEVEL 15

SHEET 26 OF 48 SHEETS
STRATA PLAN EPS1133

SCALE 1 : 200

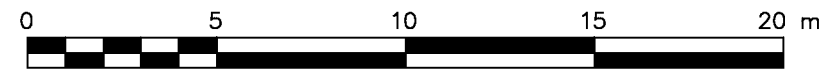

ALL DISTANCES ARE IN METRES AND DECIMALS THEREOF
THE INTENDED PLOT SIZE OF THIS PLAN IS 280mm IN WIDTH
BY 432mm IN HEIGHT (B SIZE) WHEN PLOTTED AT A SCALE OF 1:200

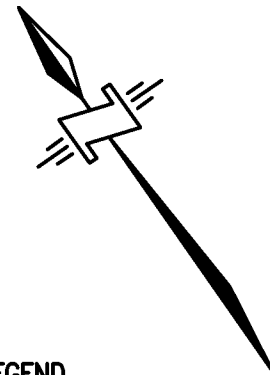

METHOD OF MEASUREMENT:
-TO CENTRELINE OF ALL DEMISING WALLS BETWEEN STRATA LOTS AND ALL STRATA LOT WALLS ADJOINING COMMON AREAS
-TO ONE (1) CENTIMETRE INSIDE OF THE OUTSIDE FACE OF EXTERIOR WALLS
-TO FACE OF CONCRETE WALLS WHERE STRATA LOTS ADJOIN CORE WALLS (IE ELEVATOR, STAIRWELL).

ALL ANGLES ARE 90° OR 45° UNLESS OTHERWISE NOTED

LEGEND

- SL — STRATA LOT
- ELEC — DENOTES ELECTRICAL
- MECH — DENOTES MECHANICAL
- ⊙ — COMMON PROPERTY
- Ⓢ — DENOTES LIMITED COMMON PROPERTY FOR STRATA LOT 31 (TYPICAL)

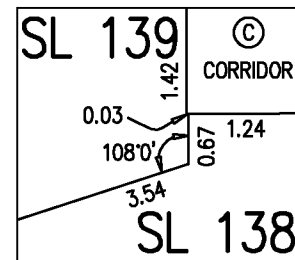

DETAIL
NOT TO SCALE

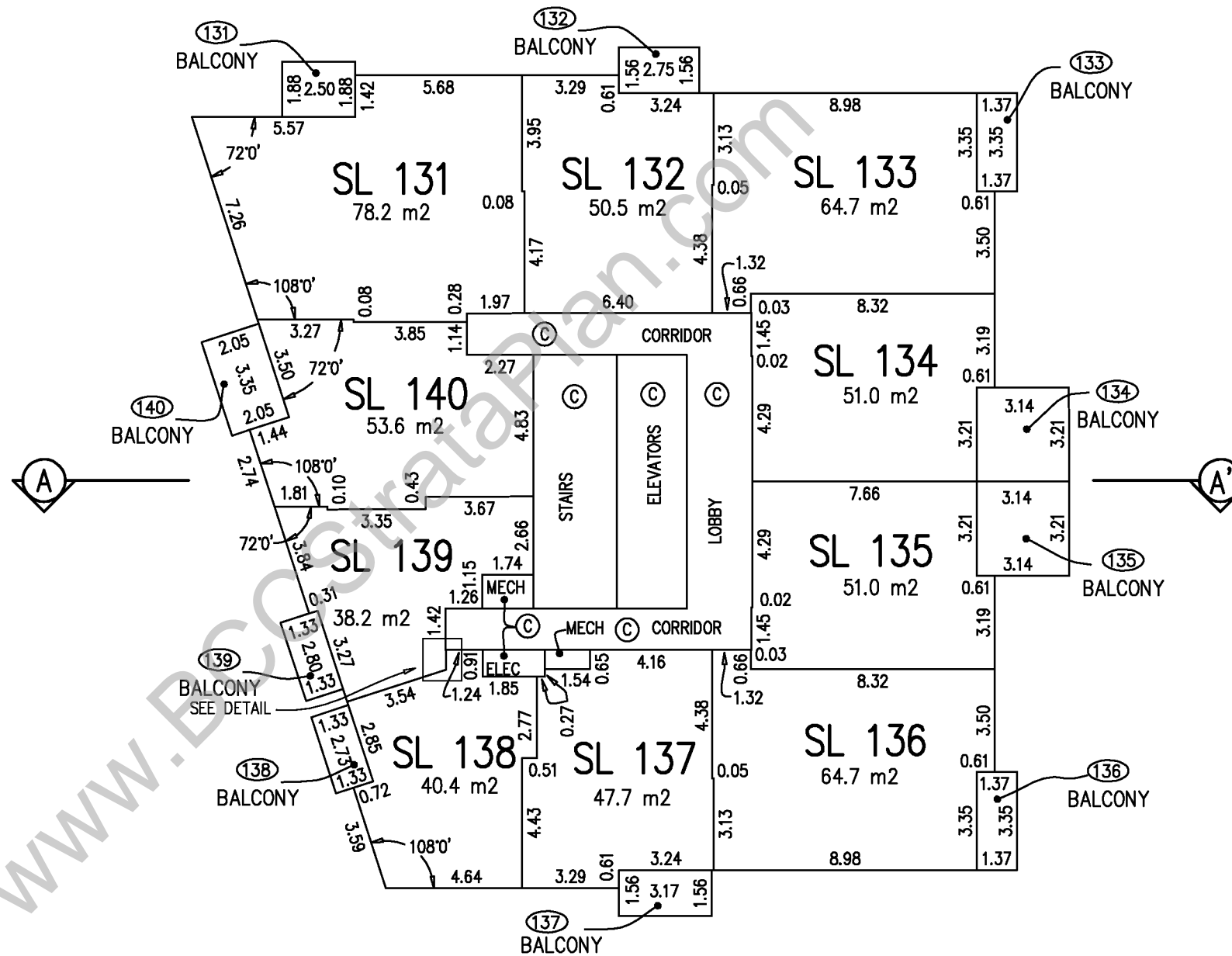

JAMES G. SHAW, BCLS, CLS
DATE: FEBRUARY 25, 2013
McELHANNEY ASSOCIATES
LAND SURVEYING LTD.
FILE: 2112-07909-24

BUILDING 1 LEVEL 17

SHEET 28 OF 48 SHEETS
STRATA PLAN EPS1133

SCALE 1 : 200

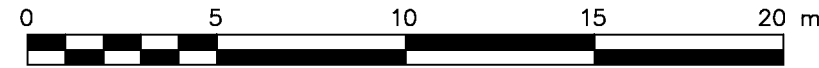

ALL DISTANCES ARE IN METRES AND DECIMALS THEREOF
THE INTENDED PLOT SIZE OF THIS PLAN IS 280mm IN WIDTH
BY 432mm IN HEIGHT (B SIZE) WHEN PLOTTED AT A SCALE OF 1:200

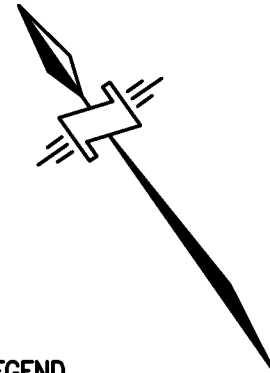

METHOD OF MEASUREMENT:

- TO CENTRELINE OF ALL DEMISING WALLS BETWEEN STRATA LOTS AND ALL STRATA LOT WALLS ADJOINING COMMON AREAS
- TO ONE (1) CENTIMETRE INSIDE OF THE OUTSIDE FACE OF EXTERIOR WALLS
- TO FACE OF CONCRETE WALLS WHERE STRATA LOTS ADJOIN CORE WALLS (IE ELEVATOR, STAIRWELL).

ALL ANGLES ARE 90° OR 45° UNLESS OTHERWISE NOTED

LEGEND

- SL — STRATA LOT
- ELEC — DENOTES ELECTRICAL
- MECH — DENOTES MECHANICAL
- ⊙ — COMMON PROPERTY
- ⊙31 — DENOTES LIMITED COMMON PROPERTY FOR STRATA LOT 31 (TYPICAL)

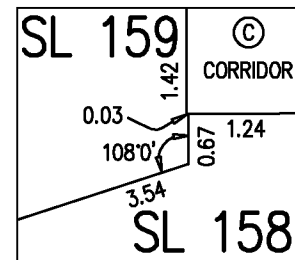

DETAIL
NOT TO SCALE

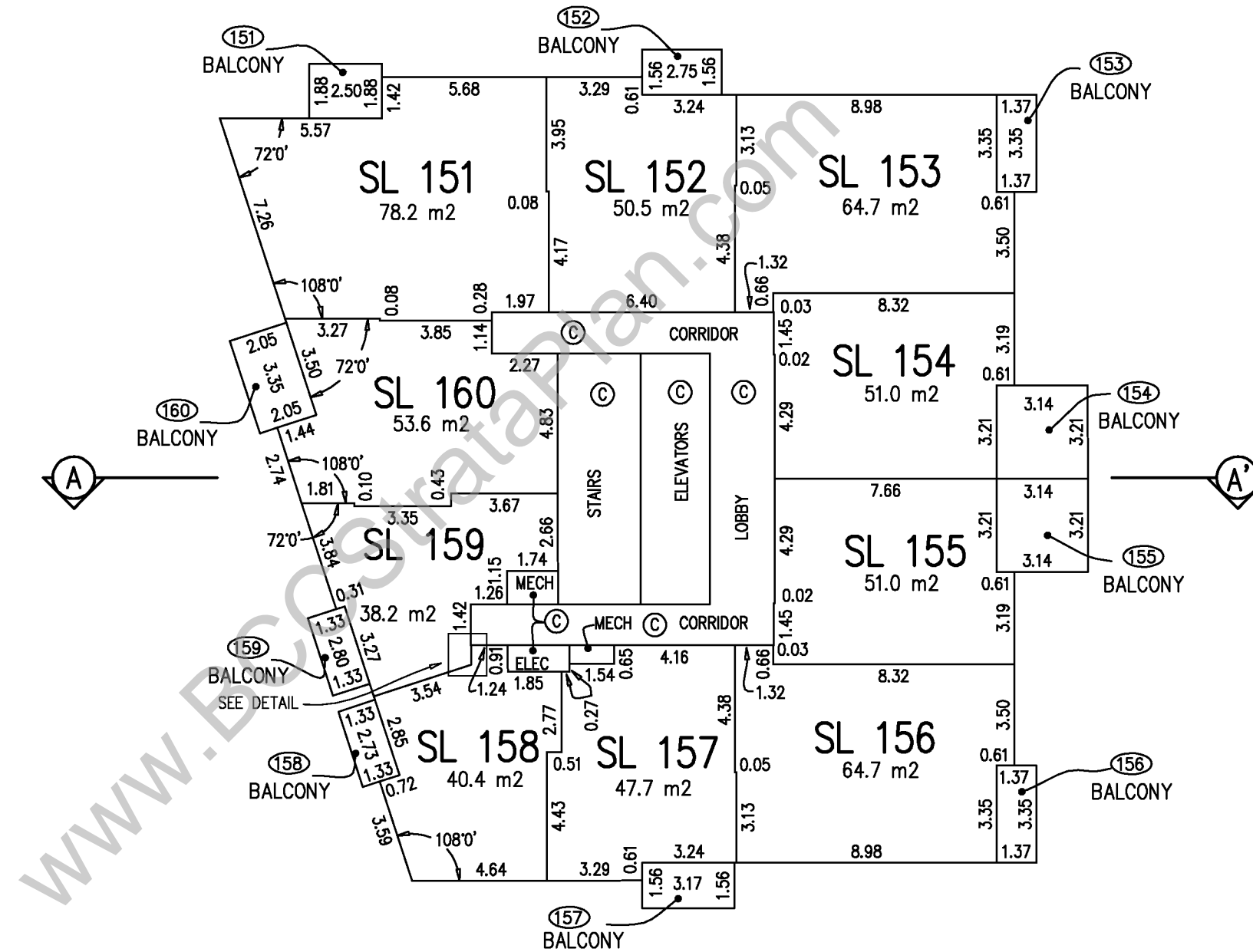

JAMES G. SHAW, BCLS, CLS
DATE: FEBRUARY 25, 2013
McELHANNEY ASSOCIATES
LAND SURVEYING LTD.
FILE: 2112-07909-24

BUILDING 1 LEVEL 18

SHEET 29 OF 48 SHEETS
STRATA PLAN EPS1133

SCALE 1 : 200



ALL DISTANCES ARE IN METRES AND DECIMALS THEREOF
THE INTENDED PLOT SIZE OF THIS PLAN IS 280mm IN WIDTH
BY 432mm IN HEIGHT (B SIZE) WHEN PLOTTED AT A SCALE OF 1:200

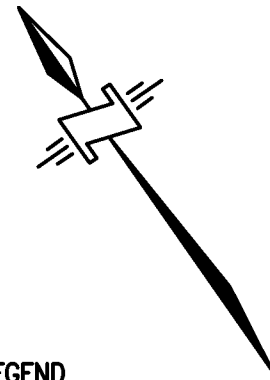

METHOD OF MEASUREMENT:
-TO CENTRELINE OF ALL DEMISING WALLS BETWEEN STRATA LOTS AND ALL STRATA LOT WALLS ADJOINING COMMON AREAS
-TO ONE (1) CENTIMETRE INSIDE OF THE OUTSIDE FACE OF EXTERIOR WALLS
-TO FACE OF CONCRETE WALLS WHERE STRATA LOTS ADJOIN CORE WALLS (IE ELEVATOR, STAIRWELL).

ALL ANGLES ARE 90° OR 45° UNLESS OTHERWISE NOTED

LEGEND

- SL — STRATA LOT
- ELEC — DENOTES ELECTRICAL
- MECH — DENOTES MECHANICAL
- ⊙ — COMMON PROPERTY
- Ⓢ — DENOTES LIMITED COMMON PROPERTY FOR STRATA LOT 31 (TYPICAL)

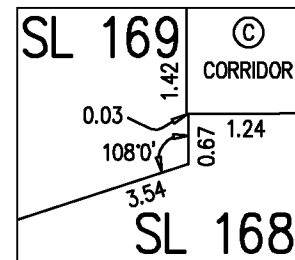

DETAIL
NOT TO SCALE

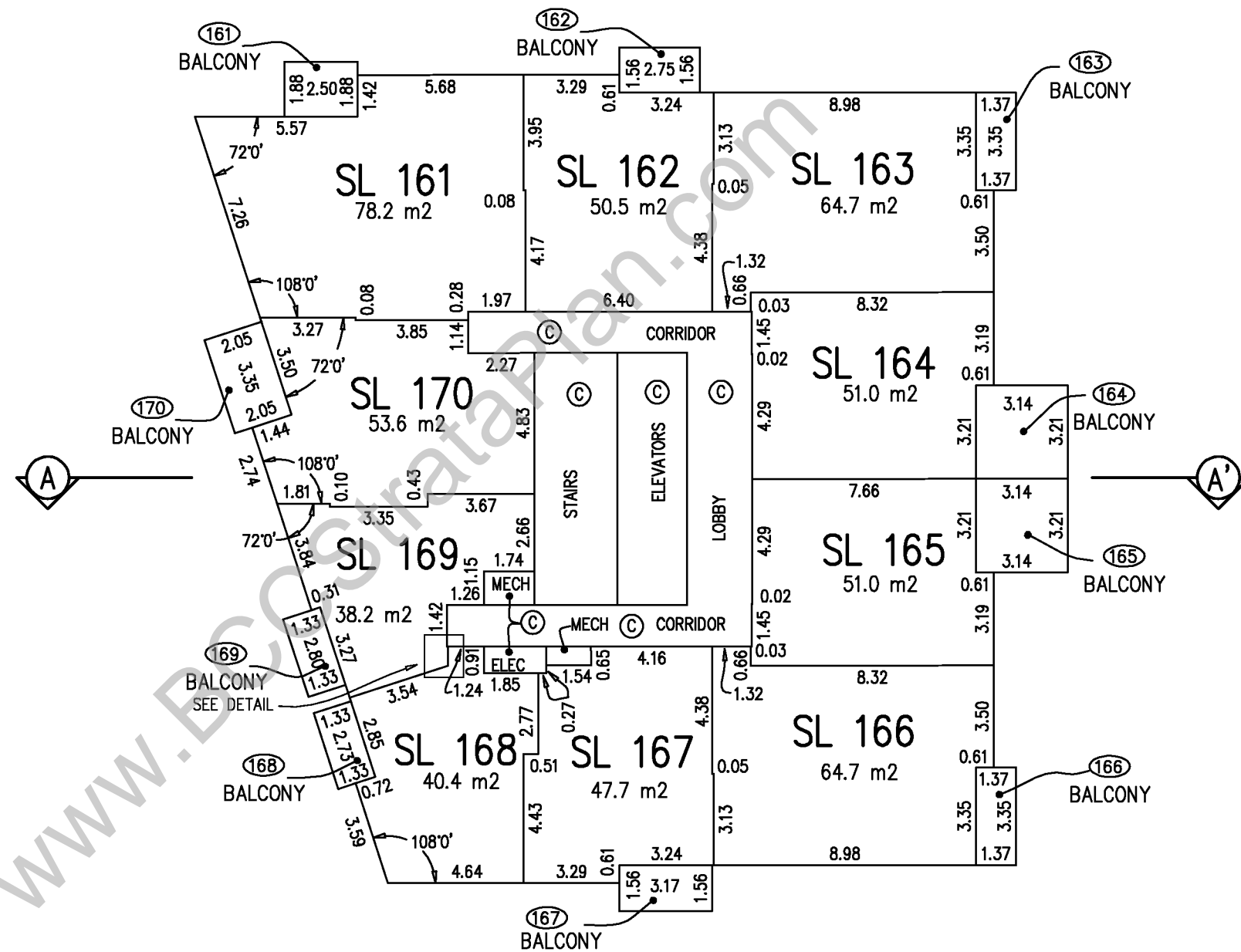

JAMES G. SHAW, BCLS, CLS
DATE: FEBRUARY 25, 2013
McELHANNEY ASSOCIATES
LAND SURVEYING LTD.
FILE: 2112-07909-24

BUILDING 1 LEVEL 19

SHEET 30 OF 48 SHEETS
STRATA PLAN EPS1133

SCALE 1 : 200

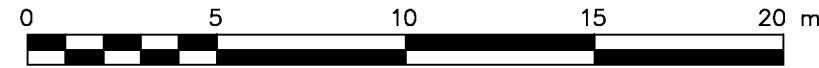

ALL DISTANCES ARE IN METRES AND DECIMALS THEREOF
THE INTENDED PLOT SIZE OF THIS PLAN IS 280mm IN WIDTH
BY 432mm IN HEIGHT (B SIZE) WHEN PLOTTED AT A SCALE OF 1:200

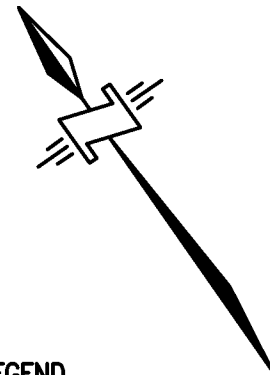

METHOD OF MEASUREMENT:

- TO CENTRELINE OF ALL DEMISING WALLS BETWEEN STRATA LOTS AND ALL STRATA LOT WALLS ADJOINING COMMON AREAS
- TO ONE (1) CENTIMETRE INSIDE OF THE OUTSIDE FACE OF EXTERIOR WALLS
- TO FACE OF CONCRETE WALLS WHERE STRATA LOTS ADJOIN CORE WALLS (IE ELEVATOR, STAIRWELL).

ALL ANGLES ARE 90° OR 45° UNLESS OTHERWISE NOTED

LEGEND

- SL — STRATA LOT
- ELEC — DENOTES ELECTRICAL
- MECH — DENOTES MECHANICAL
- ⊙ — COMMON PROPERTY
- ⊙31 — DENOTES LIMITED COMMON PROPERTY FOR STRATA LOT 31 (TYPICAL)

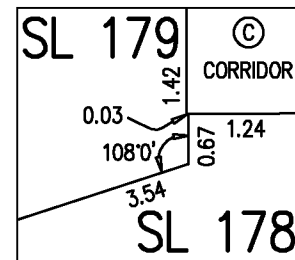

DETAIL
NOT TO SCALE

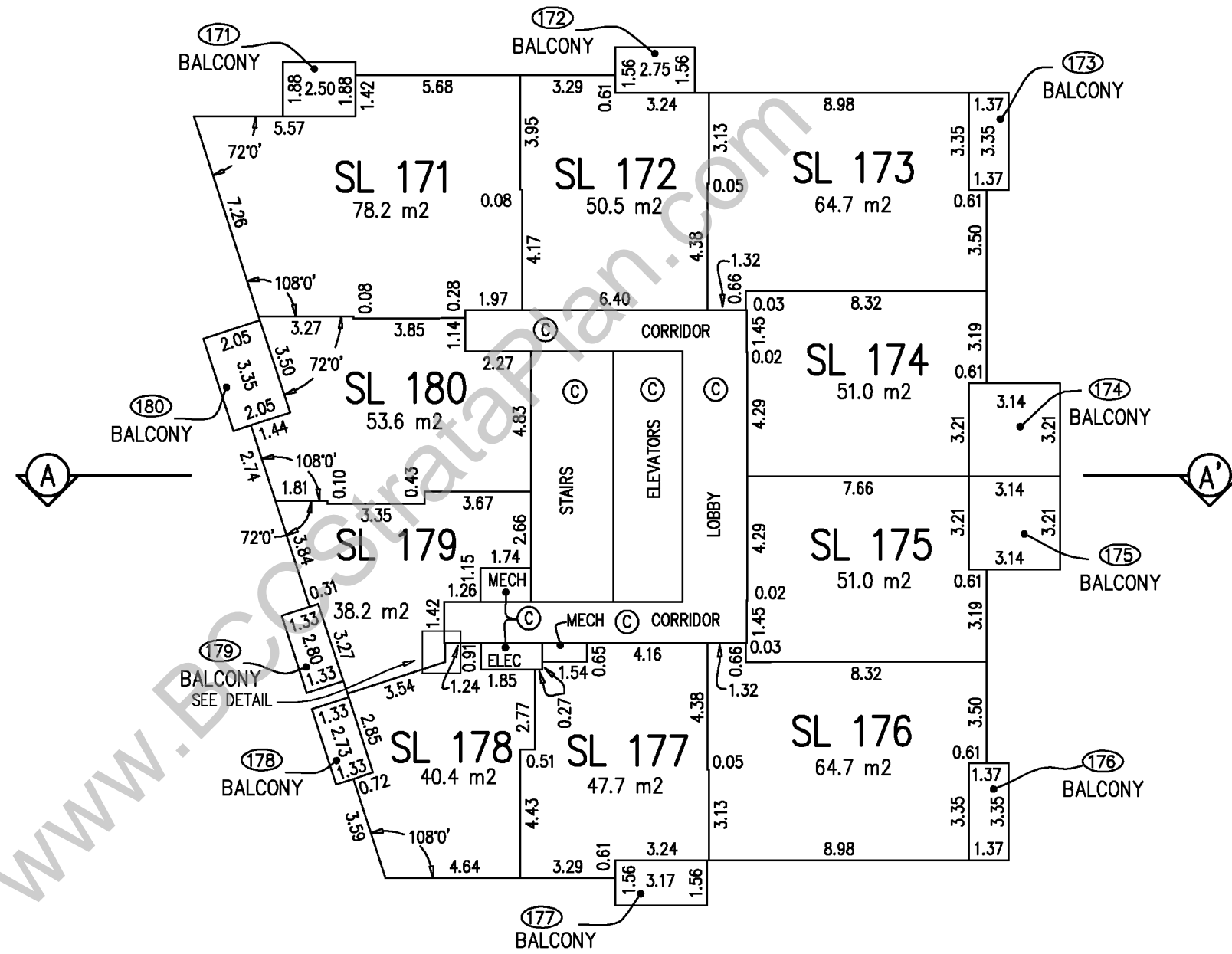

JAMES G. SHAW, BCLS, CLS
 DATE: FEBRUARY 25, 2013
 McELHANNEY ASSOCIATES
 LAND SURVEYING LTD.
 FILE: 2112-07909-24

BUILDING 1 LEVEL 20

SHEET 31 OF 48 SHEETS
STRATA PLAN EPS1133

SCALE 1 : 200

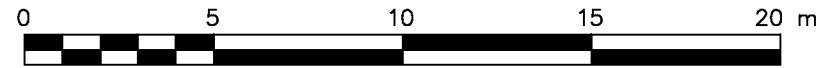

ALL DISTANCES ARE IN METRES AND DECIMALS THEREOF
THE INTENDED PLOT SIZE OF THIS PLAN IS 280mm IN WIDTH
BY 432mm IN HEIGHT (B SIZE) WHEN PLOTTED AT A SCALE OF 1:200

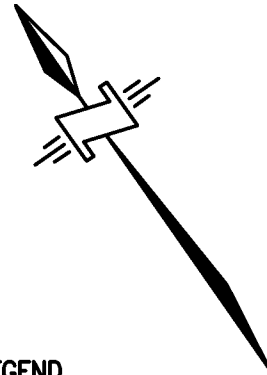

METHOD OF MEASUREMENT:
-TO CENTRELINE OF ALL DEMISING WALLS BETWEEN STRATA LOTS AND ALL STRATA LOT WALLS ADJOINING COMMON AREAS
-TO ONE (1) CENTIMETRE INSIDE OF THE OUTSIDE FACE OF EXTERIOR WALLS
-TO FACE OF CONCRETE WALLS WHERE STRATA LOTS ADJOIN CORE WALLS (IE ELEVATOR, STAIRWELL).

ALL ANGLES ARE 90° OR 45° UNLESS OTHERWISE NOTED

LEGEND

- SL — STRATA LOT
- ELEC — DENOTES ELECTRICAL
- MECH — DENOTES MECHANICAL
- (C) — COMMON PROPERTY
- (31) — DENOTES LIMITED COMMON PROPERTY FOR STRATA LOT 31 (TYPICAL)

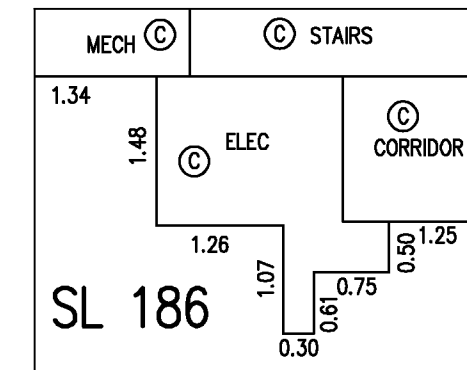
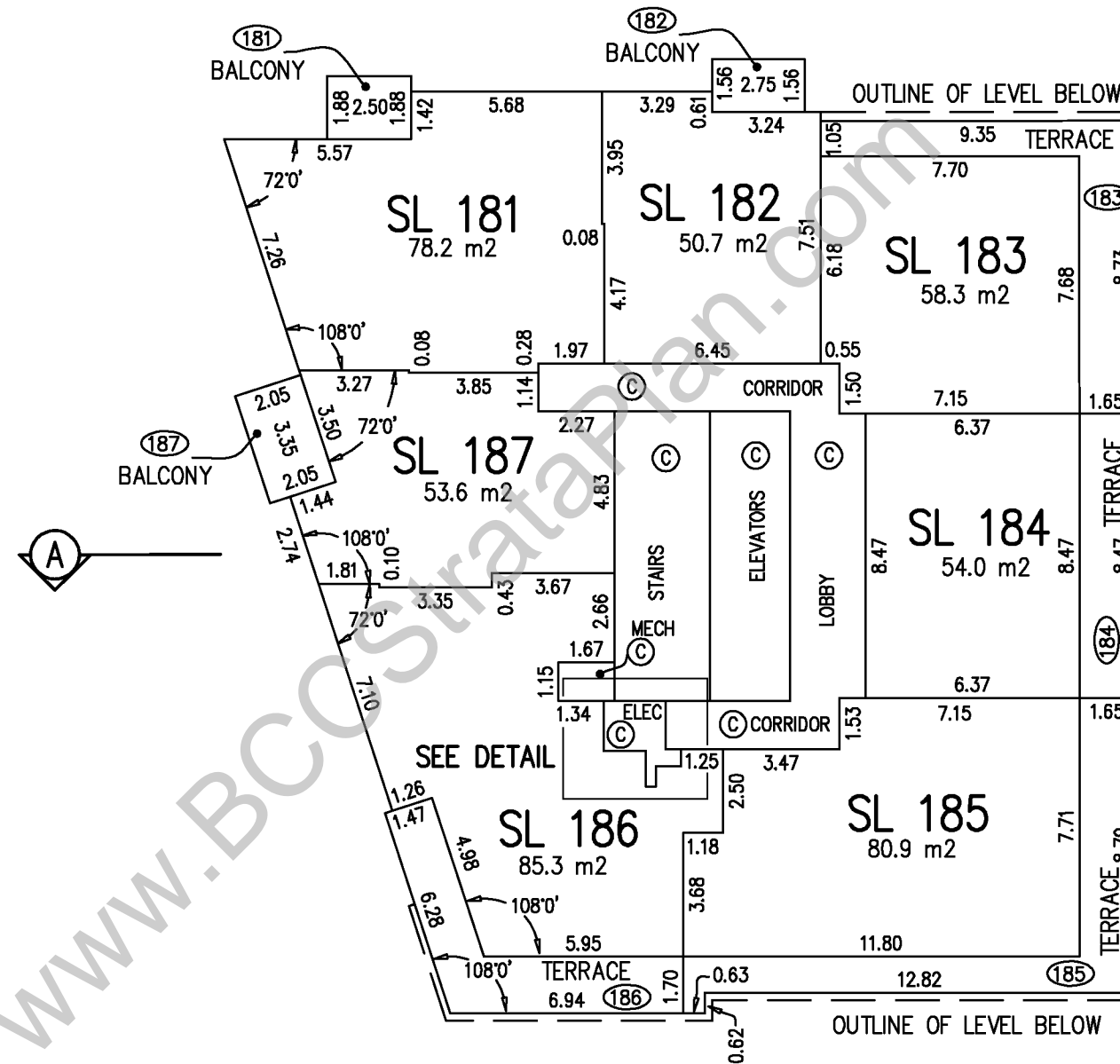

DETAIL
NOT TO SCALE

JAMES G. SHAW, BCLS, CLS
DATE: FEBRUARY 25, 2013
McELHANNEY ASSOCIATES
LAND SURVEYING LTD.
FILE: 2112-07909-24

BUILDING 1 LEVEL 21

SHEET 32 OF 48 SHEETS
STRATA PLAN EPS1133

SCALE 1 : 200

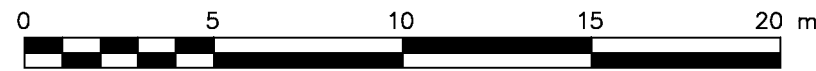

ALL DISTANCES ARE IN METRES AND DECIMALS THEREOF
THE INTENDED PLOT SIZE OF THIS PLAN IS 280mm IN WIDTH
BY 432mm IN HEIGHT (B SIZE) WHEN PLOTTED AT A SCALE OF 1:200

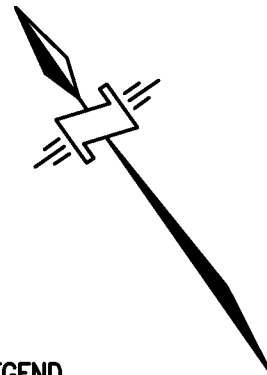

METHOD OF MEASUREMENT:

- TO CENTRELINE OF ALL DEMISING WALLS BETWEEN STRATA LOTS AND ALL STRATA LOT WALLS ADJOINING COMMON AREAS
- TO ONE (1) CENTIMETRE INSIDE OF THE OUTSIDE FACE OF EXTERIOR WALLS
- TO FACE OF CONCRETE WALLS WHERE STRATA LOTS ADJOIN CORE WALLS (IE ELEVATOR, STAIRWELL).

ALL ANGLES ARE 90° OR 45° UNLESS OTHERWISE NOTED

LEGEND

- SL — STRATA LOT
- ELEC — DENOTES ELECTRICAL
- MECH — DENOTES MECHANICAL
- ⊙ — COMMON PROPERTY
- ③① — DENOTES LIMITED COMMON PROPERTY FOR STRATA LOT 31 (TYPICAL)

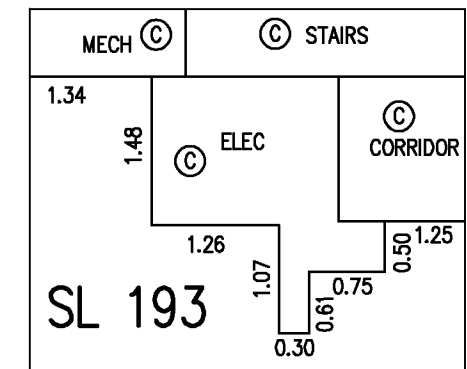
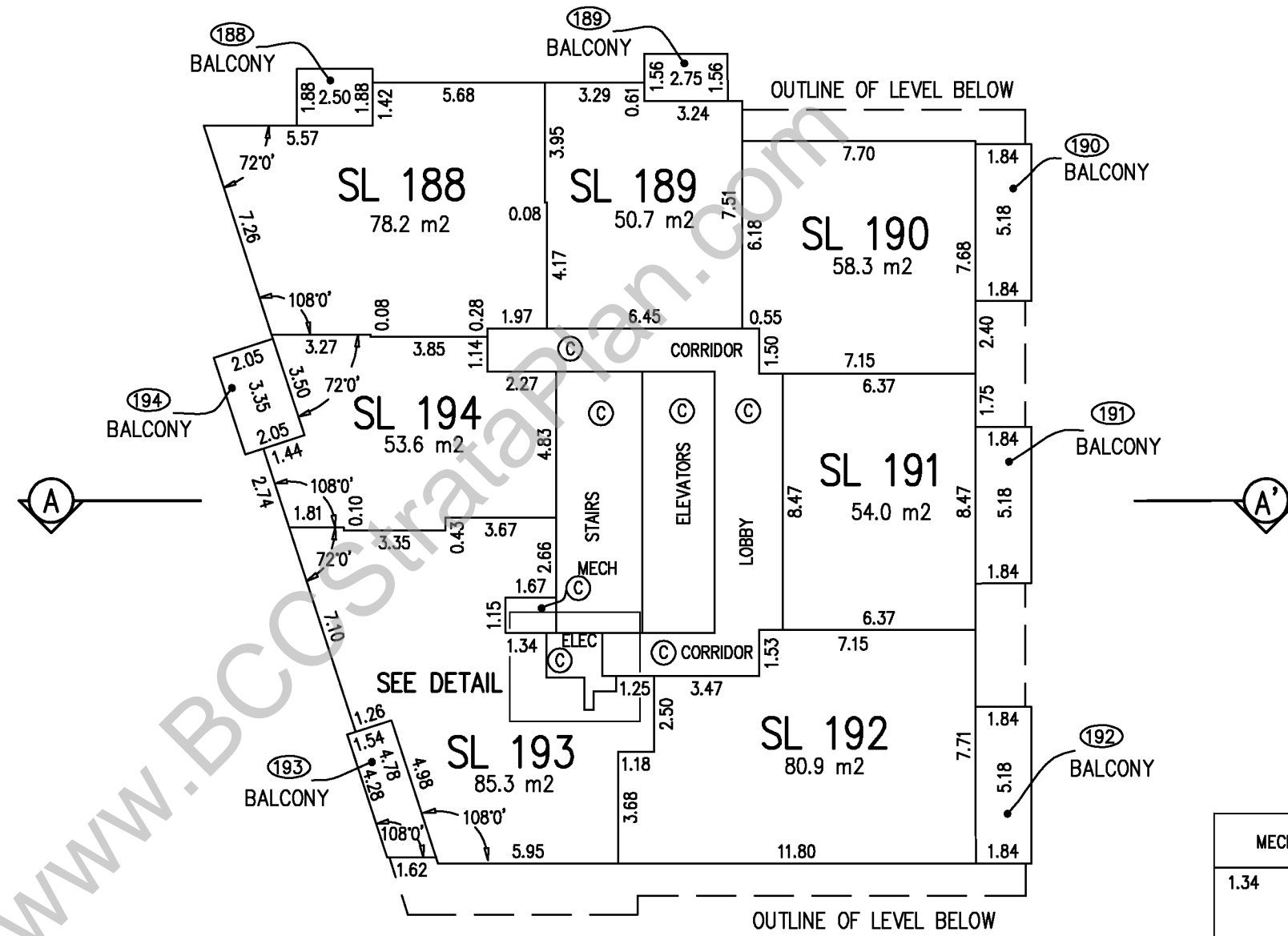

DETAIL
NOT TO SCALE

JAMES G. SHAW, BCLS, CLS
DATE: FEBRUARY 25, 2013
McELHANNEY ASSOCIATES
LAND SURVEYING LTD.
FILE: 2112-07909-24

BUILDING 1 LEVEL 22

SHEET 33 OF 48 SHEETS
STRATA PLAN EPS1133

SCALE 1 : 200

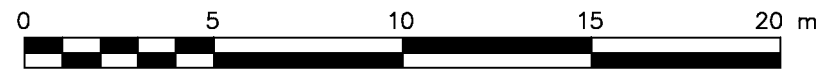

ALL DISTANCES ARE IN METRES AND DECIMALS THEREOF
THE INTENDED PLOT SIZE OF THIS PLAN IS 280mm IN WIDTH
BY 432mm IN HEIGHT (B SIZE) WHEN PLOTTED AT A SCALE OF 1:200

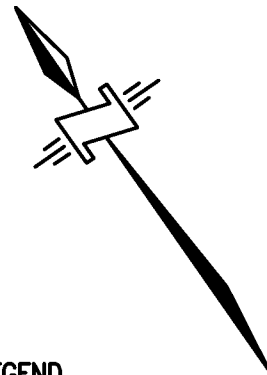

METHOD OF MEASUREMENT:
-TO CENTRELINE OF ALL DEMISING WALLS BETWEEN STRATA LOTS AND ALL STRATA LOT WALLS ADJOINING COMMON AREAS
-TO ONE (1) CENTIMETRE INSIDE OF THE OUTSIDE FACE OF EXTERIOR WALLS
-TO FACE OF CONCRETE WALLS WHERE STRATA LOTS ADJOIN CORE WALLS (IE ELEVATOR, STAIRWELL).

ALL ANGLES ARE 90° OR 45° UNLESS OTHERWISE NOTED

LEGEND

- SL — STRATA LOT
- ELEC — DENOTES ELECTRICAL
- MECH — DENOTES MECHANICAL
- ⊙ — COMMON PROPERTY
- Ⓢ — DENOTES LIMITED COMMON PROPERTY FOR STRATA LOT 31 (TYPICAL)

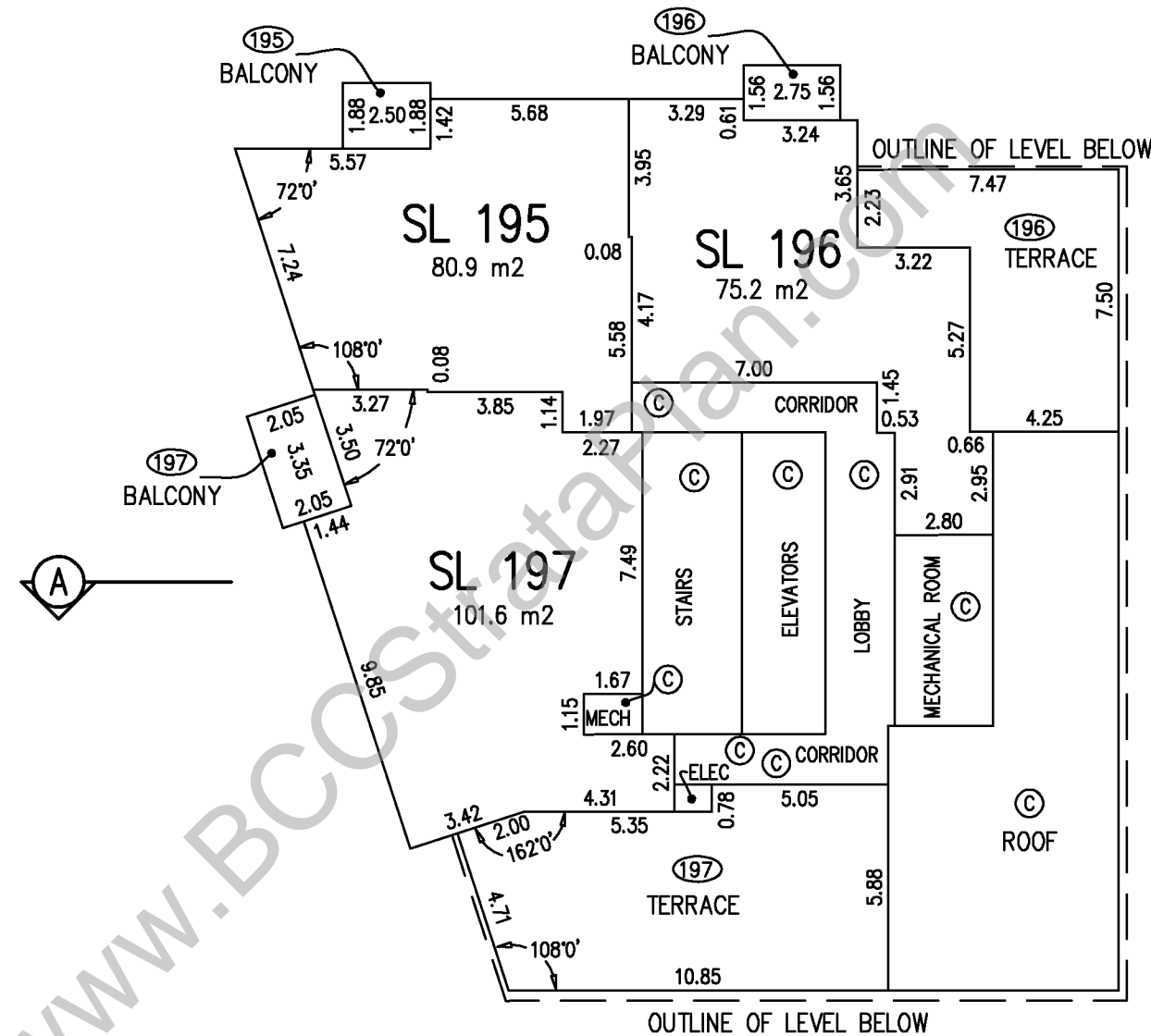

JAMES G. SHAW, BCLS, CLS
DATE: FEBRUARY 25, 2013
McELHANNEY ASSOCIATES
LAND SURVEYING LTD.
FILE: 2112-07909-24

BUILDING 1 MECHANICAL LEVEL

SHEET 34 OF 48 SHEETS
STRATA PLAN EPS1133

SCALE 1 : 200

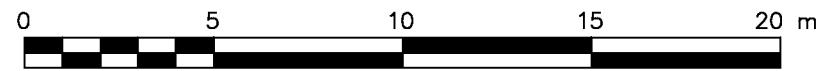

ALL DISTANCES ARE IN METRES AND DECIMALS THEREOF
THE INTENDED PLOT SIZE OF THIS PLAN IS 280mm IN WIDTH
BY 432mm IN HEIGHT (B SIZE) WHEN PLOTTED AT A SCALE OF 1:200

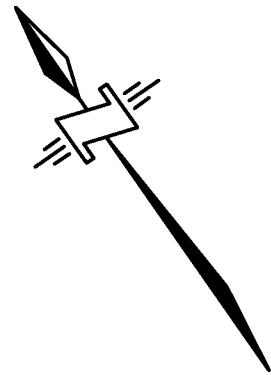

LEGEND

© COMMON PROPERTY

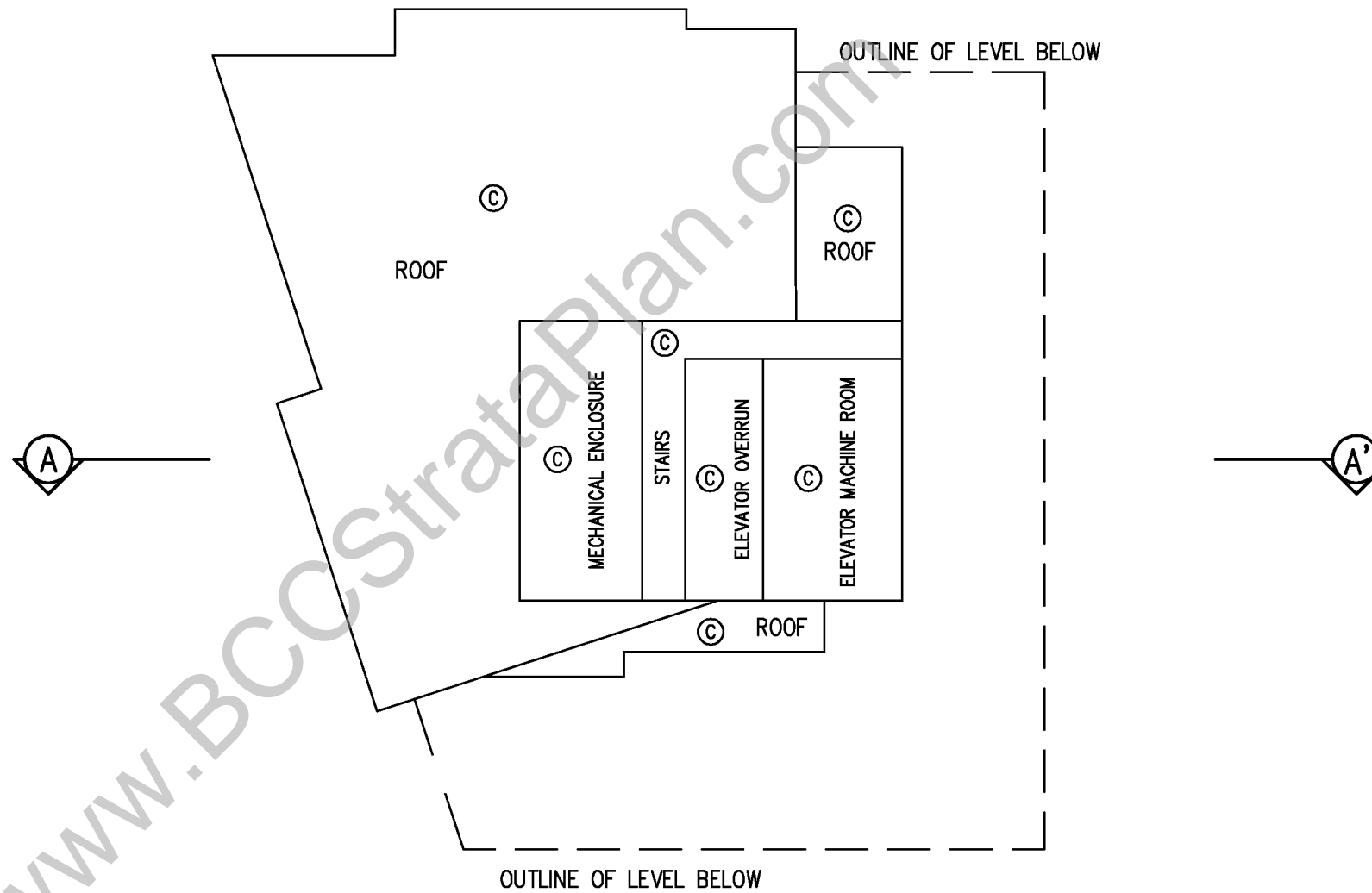

JAMES G. SHAW, BCLS, CLS
DATE: FEBRUARY 25, 2013
McELHANNEY ASSOCIATES
LAND SURVEYING LTD.
FILE: 2112-07909-24

BUILDING 1 ROOF LEVEL

SHEET 35 OF 48 SHEETS
STRATA PLAN EPS1133

SCALE 1 : 200

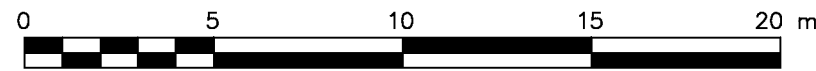

ALL DISTANCES ARE IN METRES AND DECIMALS THEREOF
THE INTENDED PLOT SIZE OF THIS PLAN IS 280mm IN WIDTH
BY 432mm IN HEIGHT (B SIZE) WHEN PLOTTED AT A SCALE OF 1:200

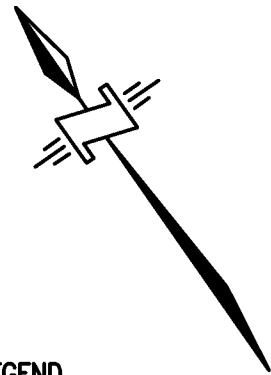

LEGEND

© COMMON PROPERTY

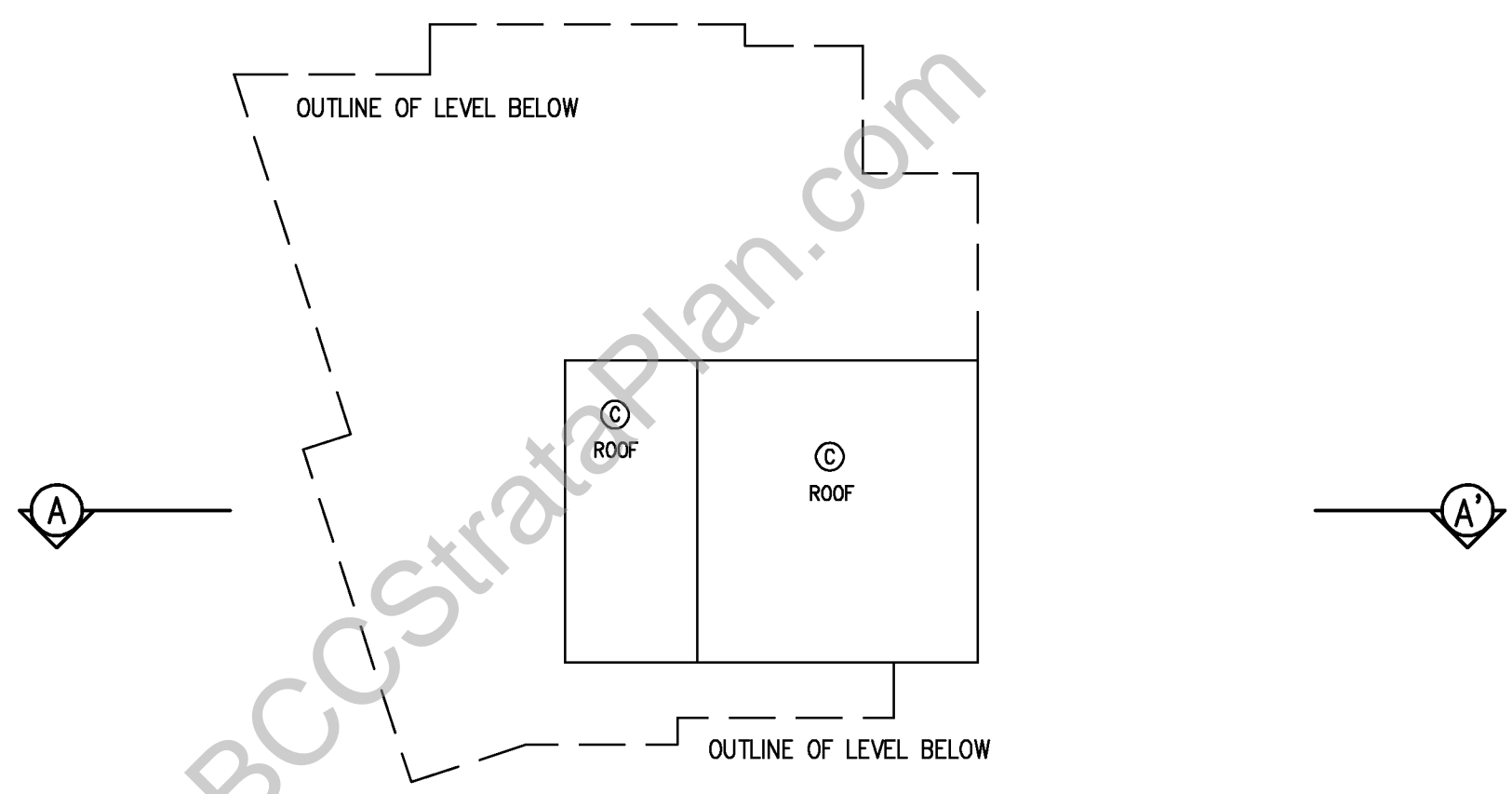

WWW.BCCStrataPlan.com

JAMES G. SHAW, BCLS, CLS
DATE: FEBRUARY 25, 2013
McELHANNEY ASSOCIATES
LAND SURVEYING LTD.
FILE: 2112-07909-24

BUILDING 2 GROUND LEVEL

SCALE 1 : 200



ALL DISTANCES ARE IN METRES AND DECIMALS THEREOF

THE INTENDED PLOT SIZE OF THIS PLAN IS 280mm IN WIDTH BY 432mm IN HEIGHT (B SIZE) WHEN PLOTTED AT A SCALE OF 1:200

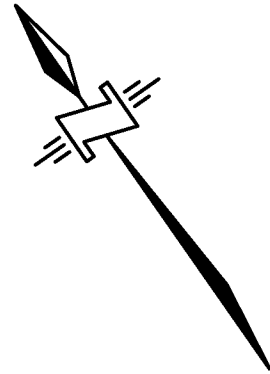

LEGEND

- ELEC _____ DENOTES ELECTRICAL
- VEST _____ DENOTES VESTIBULE
- Ⓢ _____ COMMON PROPERTY

SHEET 36 OF 48 SHEETS
STRATA PLAN EPS1133

KINGSWAY

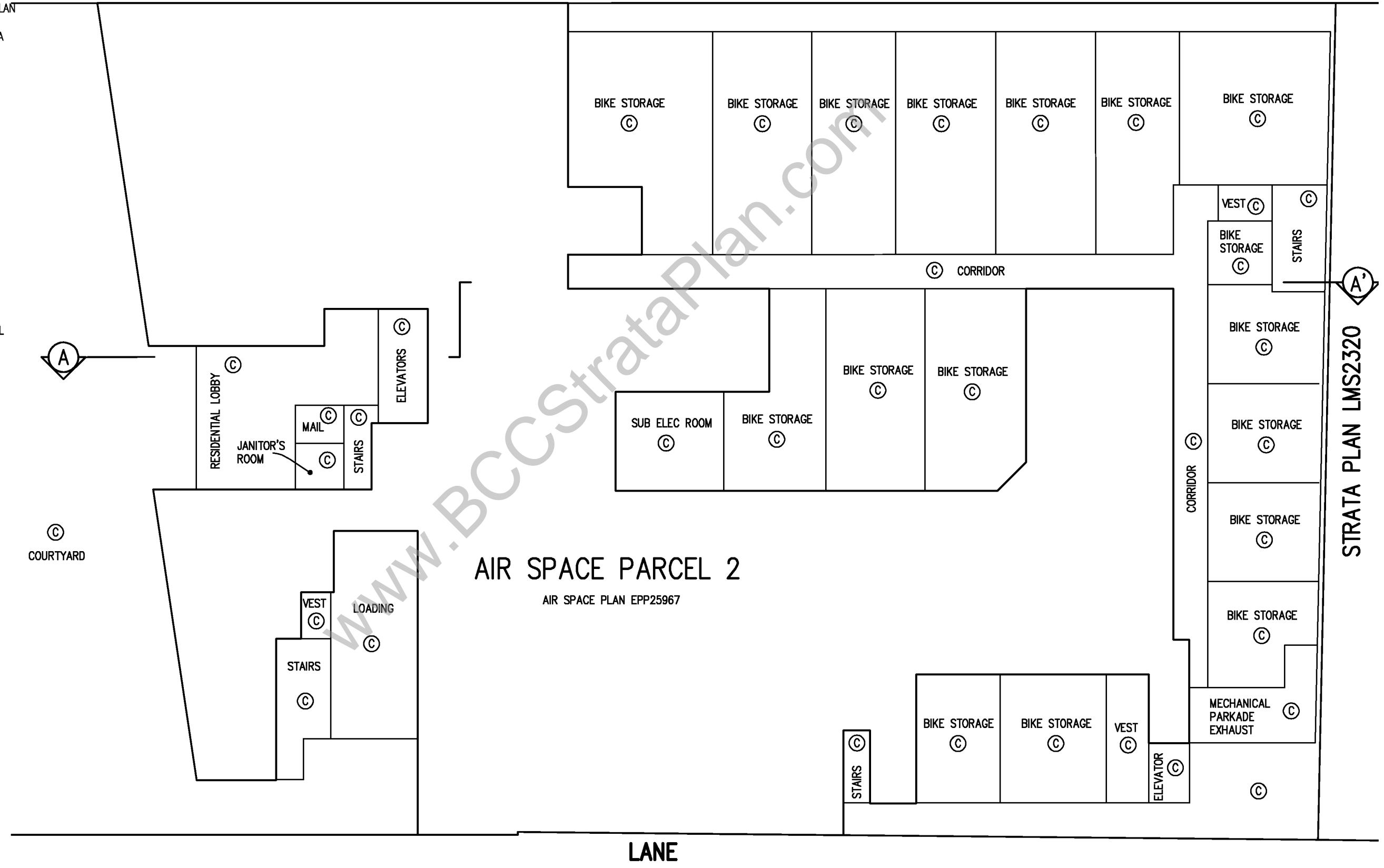

STRATA PLAN LMS2320

JAMES G. SHAW, BCLS, CLS
 DATE: FEBRUARY 25, 2013
 McELHANNEY ASSOCIATES
 LAND SURVEYING LTD.
 FILE: 2112-07909-24

BUILDING 2 GROUND LEVEL UPPER

SCALE 1 : 200

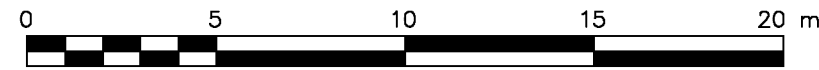

ALL DISTANCES ARE IN METRES AND DECIMALS THEREOF

THE INTENDED PLOT SIZE OF THIS PLAN IS 280mm IN WIDTH BY 432mm IN HEIGHT (B SIZE) WHEN PLOTTED AT A SCALE OF 1:200

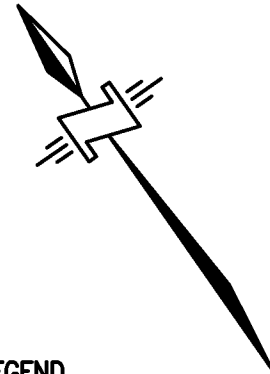

LEGEND

- ELEC _____ DENOTES ELECTRICAL
- MECH _____ DENOTES MECHANICAL
- WC _____ DENOTES WASHROOM
- Ⓢ _____ COMMON PROPERTY

SHEET 37 OF 48 SHEETS

STRATA PLAN EPS1133

KINGSWAY

AIR SPACE PARCEL 2

AIR SPACE PLAN EPP25967

STRATA PLAN LMS2320

LANE

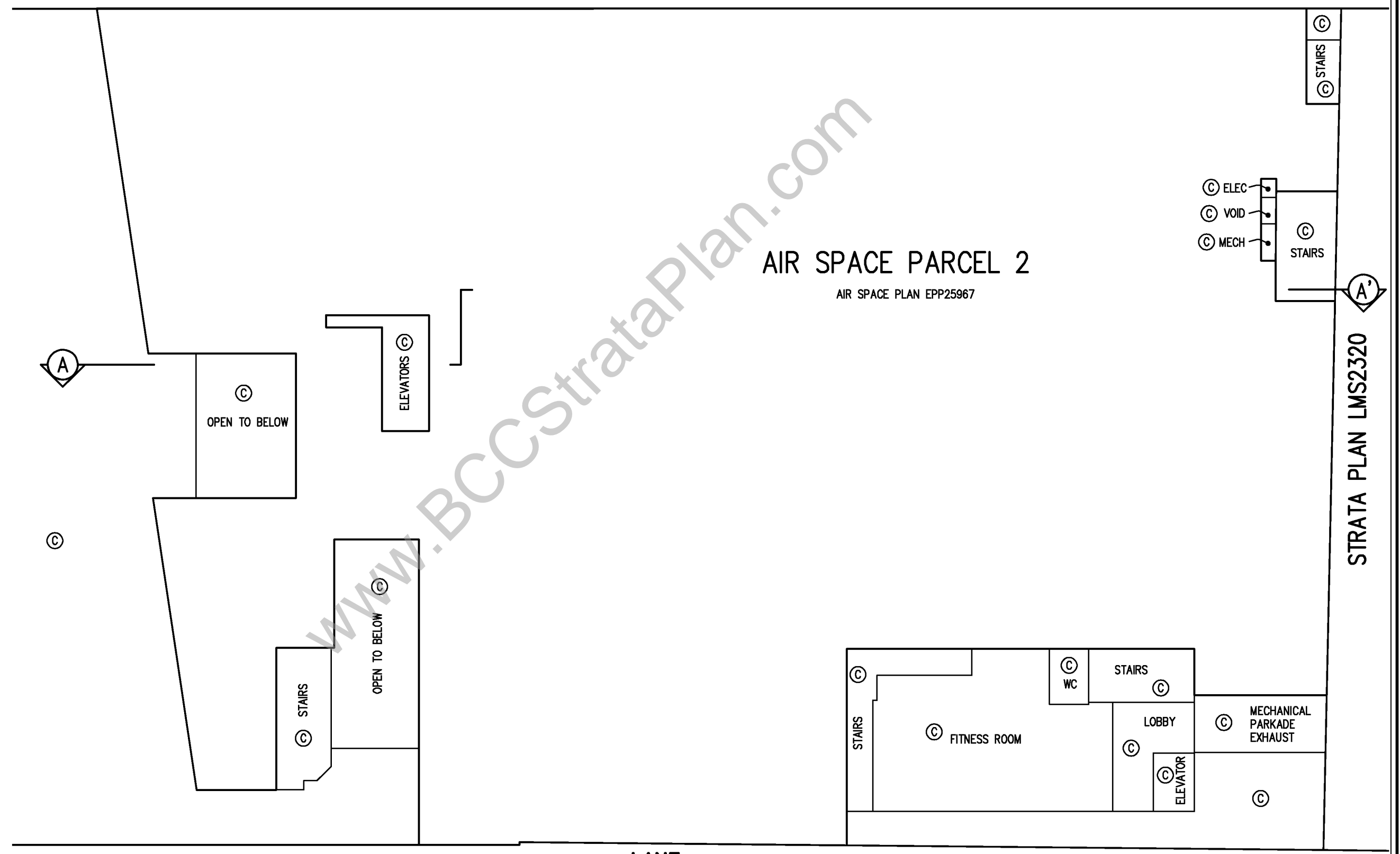

JAMES G. SHAW, BCLS, CLS
 DATE: FEBRUARY 25, 2013
 McELHANNEY ASSOCIATES
 LAND SURVEYING LTD.
 FILE: 2112-07909-24

BUILDING 2 GROUND LEVEL MEZZANINE

SHEET 38 OF 48 SHEETS
STRATA PLAN EPS1133

SCALE 1 : 200

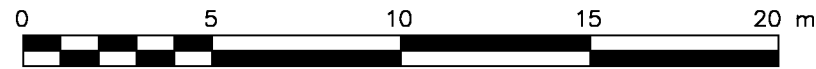

ALL DISTANCES ARE IN METRES AND DECIMALS THEREOF

THE INTENDED PLOT SIZE OF THIS PLAN IS 280mm IN WIDTH BY 432mm IN HEIGHT (B SIZE) WHEN PLOTTED AT A SCALE OF 1:200

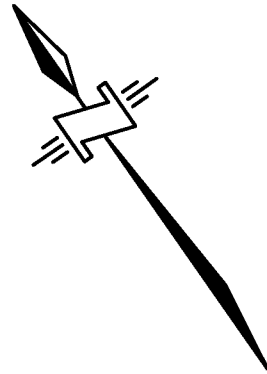

KINGSWAY

AIR SPACE PARCEL 2

AIR SPACE PLAN EPP25967

LEGEND

- ELEC _____ DENOTES ELECTRICAL
- MECH _____ DENOTES MECHANICAL
- Ⓢ _____ COMMON PROPERTY

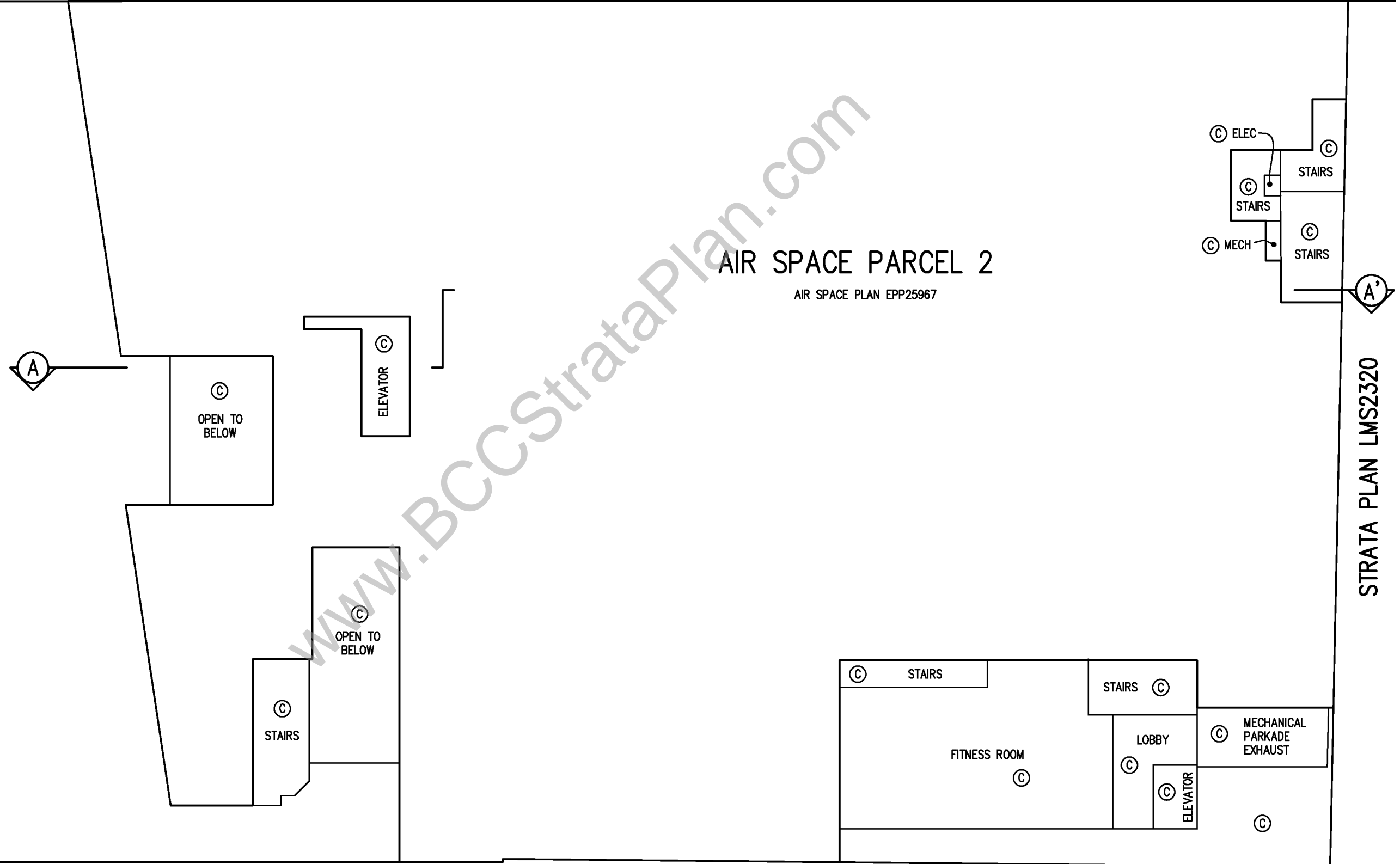

STRATA PLAN LMS2320

JAMES G. SHAW, BCLS, CLS
DATE: FEBRUARY 25, 2013
McELHANNEY ASSOCIATES
LAND SURVEYING LTD.
FILE: 2112-07909-24

LANE

BUILDING 2 LEVEL 2

STRATA LOTS 198 TO 219

SCALE 1 : 200

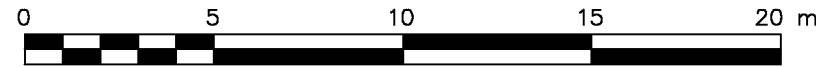

ALL DISTANCES ARE IN METRES AND DECIMALS THEREOF

THE INTENDED PLOT SIZE OF THIS PLAN IS 280mm IN WIDTH BY 432mm IN HEIGHT (B SIZE) WHEN PLOTTED AT A SCALE OF 1:200

METHOD OF MEASUREMENT:

- TO CENTRELINE OF ALL DEMISING WALLS BETWEEN STRATA LOTS AND ALL STRATA LOT WALLS ADJOINING COMMON AREAS
- TO ONE (1) CENTIMETRE INSIDE OF THE OUTSIDE FACE OF EXTERIOR WALLS
- TO FACE OF CONCRETE WALLS WHERE STRATA LOTS ADJOIN CORE WALLS (IE ELEVATOR, STAIRWELL).

ALL ANGLES ARE 90° OR 45° UNLESS OTHERWISE NOTED

SHEET 39 OF 48 SHEETS

STRATA PLAN EPS1133

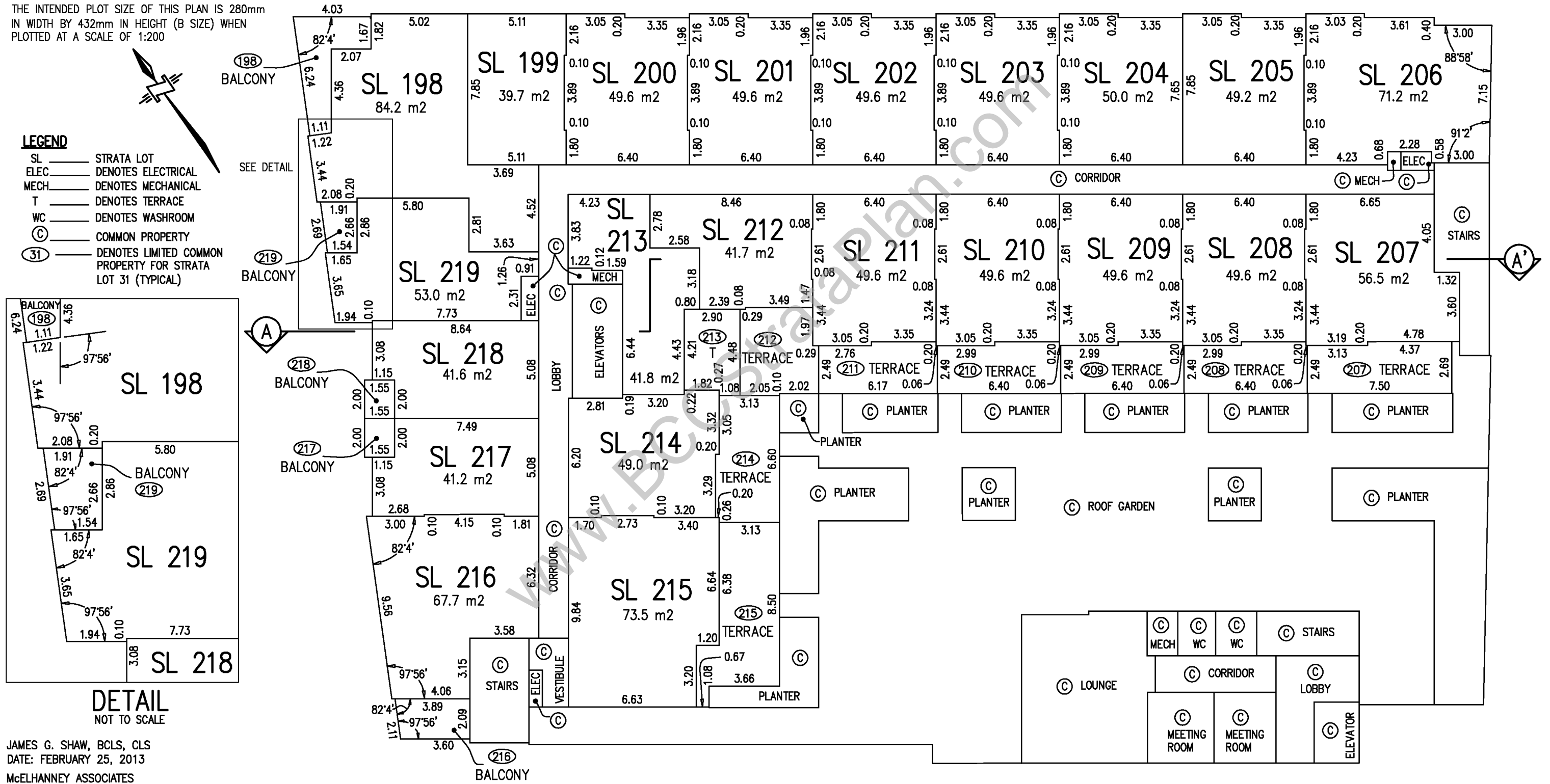

- ### LEGEND
- SL — STRATA LOT
 - ELEC — DENOTES ELECTRICAL
 - MECH — DENOTES MECHANICAL
 - T — DENOTES TERRACE
 - WC — DENOTES WASHROOM
 - (C) — COMMON PROPERTY
 - (31) — DENOTES LIMITED COMMON PROPERTY FOR STRATA LOT 31 (TYPICAL)

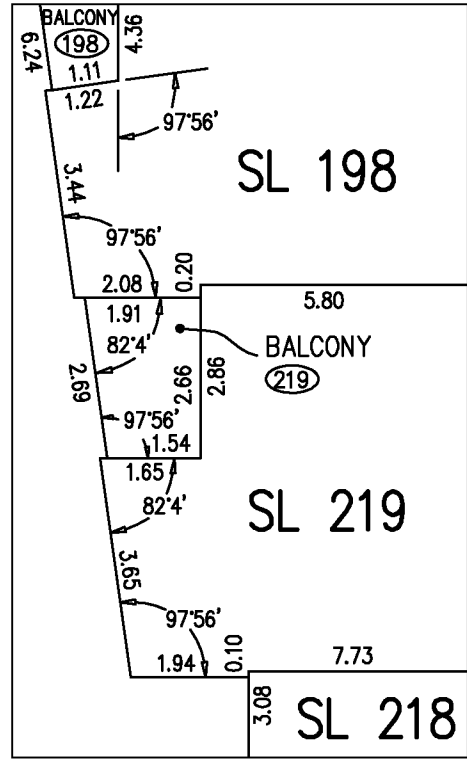

JAMES G. SHAW, BCLS, CLS
 DATE: FEBRUARY 25, 2013
 McELHANNEY ASSOCIATES
 LAND SURVEYING LTD.
 FILE: 2112-07909-24

BUILDING 2 LEVEL 4

SHEET 41 OF 48 SHEETS

STRATA PLAN EPS1133

SCALE 1 : 200



ALL DISTANCES ARE IN METRES AND DECIMALS THEREOF

THE INTENDED PLOT SIZE OF THIS PLAN IS 280mm IN WIDTH BY 432mm IN HEIGHT (B SIZE) WHEN PLOTTED AT A SCALE OF 1:200

METHOD OF MEASUREMENT:

- TO CENTRELINE OF ALL DEMISING WALLS BETWEEN STRATA LOTS AND ALL STRATA LOT WALLS ADJOINING COMMON AREAS
- TO ONE (1) CENTIMETRE INSIDE OF THE OUTSIDE FACE OF EXTERIOR WALLS
- TO FACE OF CONCRETE WALLS WHERE STRATA LOTS ADJOIN CORE WALLS (IE ELEVATOR, STAIRWELL).

ALL ANGLES ARE 90° OR 45° UNLESS OTHERWISE NOTED

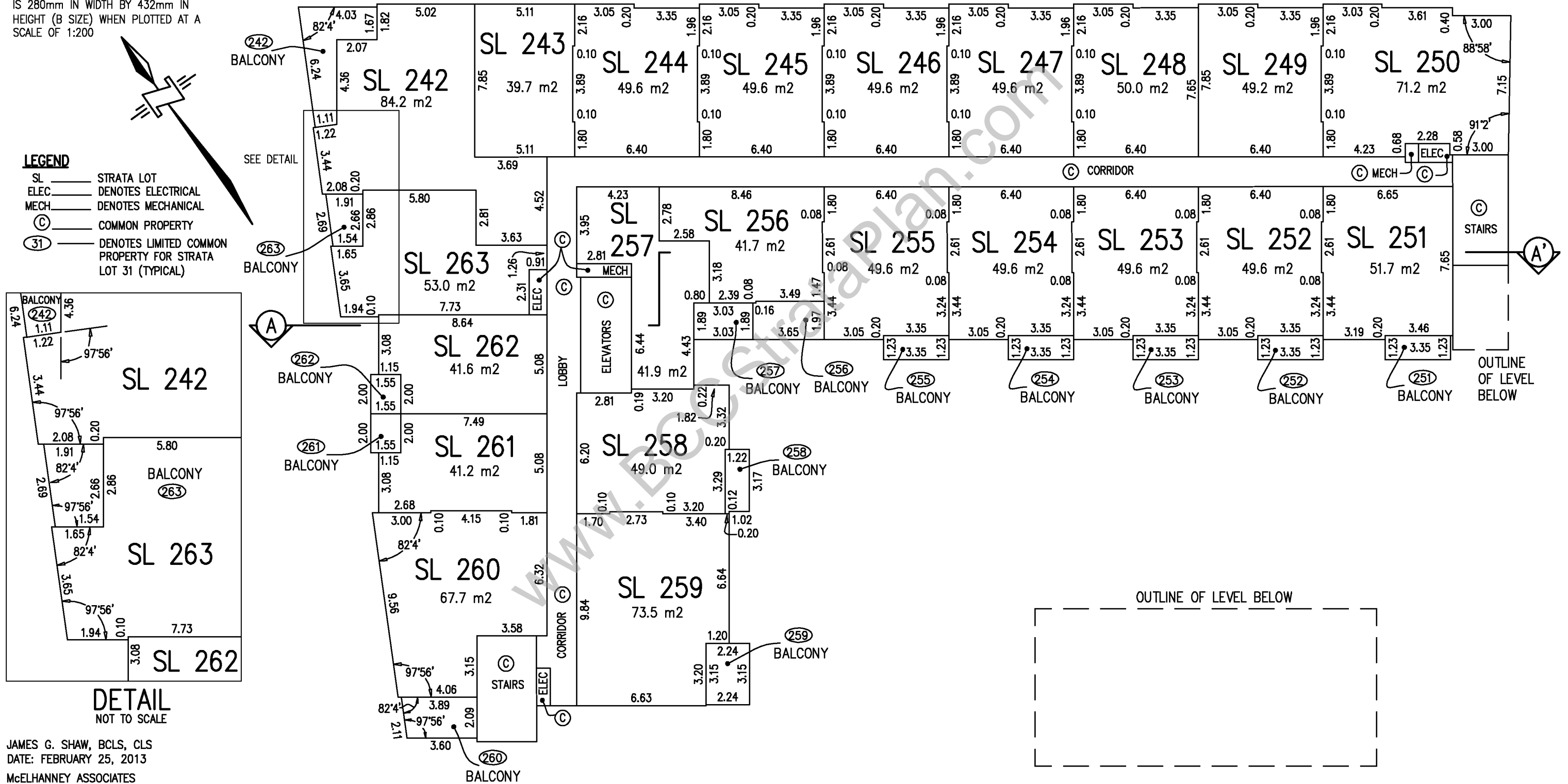

- LEGEND**
- SL STRATA LOT
 - ELEC DENOTES ELECTRICAL
 - MECH DENOTES MECHANICAL
 - (C) COMMON PROPERTY
 - (31) DENOTES LIMITED COMMON PROPERTY FOR STRATA LOT 31 (TYPICAL)

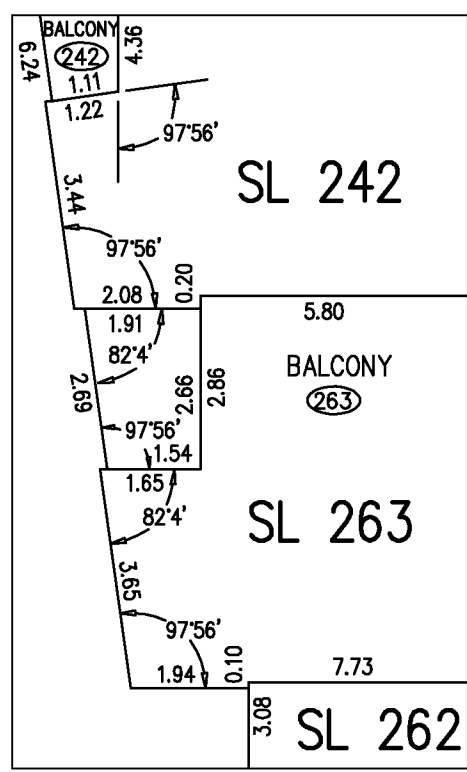

JAMES G. SHAW, BCLS, CLS
 DATE: FEBRUARY 25, 2013
 McELHANNEY ASSOCIATES
 LAND SURVEYING LTD.
 FILE: 2112-07909-24

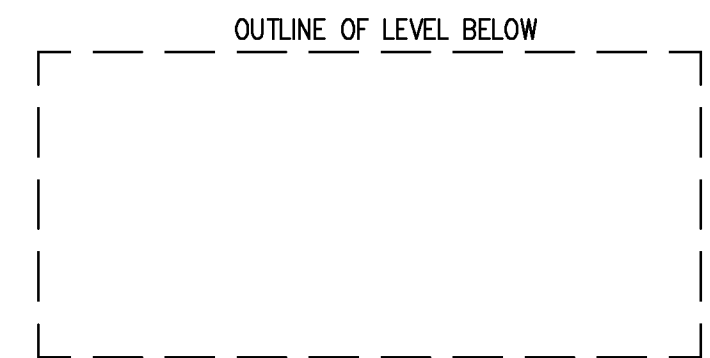

BUILDING 2 LEVEL 5

SHEET 42 OF 48 SHEETS

STRATA PLAN EPS1133

SCALE 1 : 200

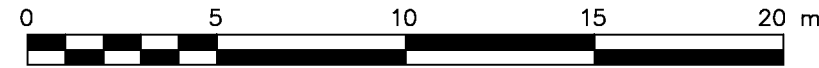

ALL DISTANCES ARE IN METRES AND DECIMALS THEREOF

THE INTENDED PLOT SIZE OF THIS PLAN IS 280mm IN WIDTH BY 432mm IN HEIGHT (B SIZE) WHEN PLOTTED AT A SCALE OF 1:200

METHOD OF MEASUREMENT:

- TO CENTRELINE OF ALL DEMISING WALLS BETWEEN STRATA LOTS AND ALL STRATA LOT WALLS ADJOINING COMMON AREAS
- TO ONE (1) CENTIMETRE INSIDE OF THE OUTSIDE FACE OF EXTERIOR WALLS
- TO FACE OF CONCRETE WALLS WHERE STRATA LOTS ADJOIN CORE WALLS (IE ELEVATOR, STAIRWELL).

ALL ANGLES ARE 90° OR 45° UNLESS OTHERWISE NOTED

LEGEND

- SL STRATA LOT
- ELEC DENOTES ELECTRICAL
- MECH DENOTES MECHANICAL
- (C) COMMON PROPERTY
- (31) DENOTES LIMITED COMMON PROPERTY FOR STRATA LOT 31 (TYPICAL)

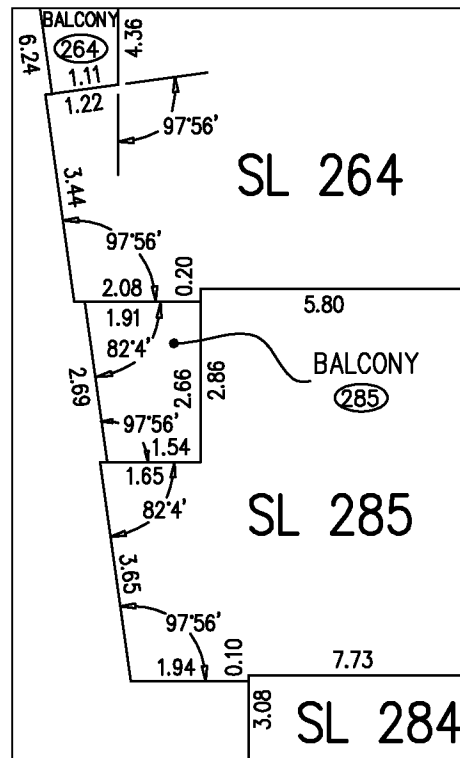

DETAIL NOT TO SCALE

JAMES G. SHAW, BCLS, CLS
 DATE: FEBRUARY 25, 2013
 McELHANNEY ASSOCIATES
 LAND SURVEYING LTD.
 FILE: 2112-07909-24

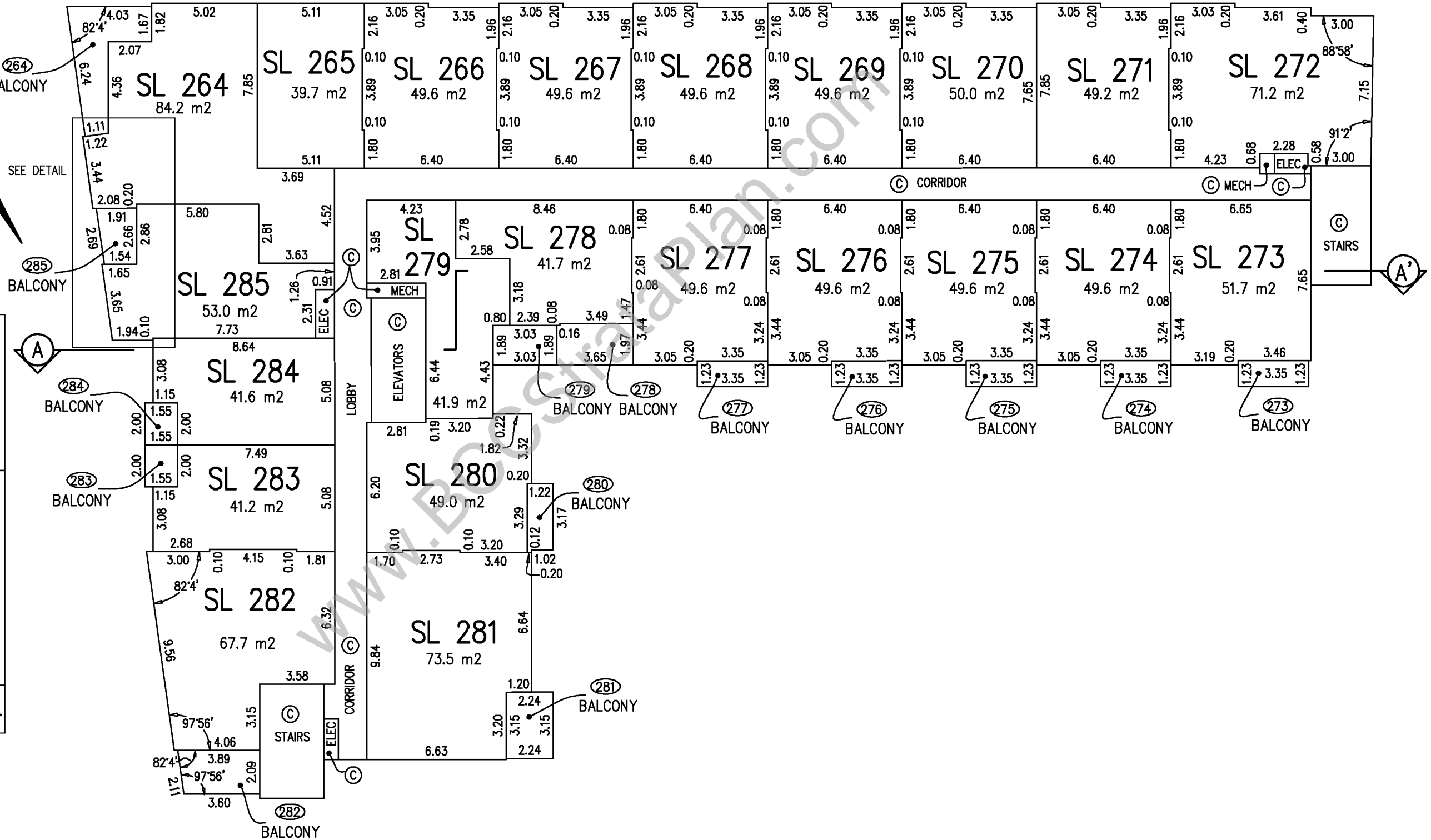

BUILDING 2 LEVEL 6

STRATA PLAN EPS1133

SHEET 43 OF 48 SHEETS

SCALE 1 : 200



ALL DISTANCES ARE IN METRES AND DECIMALS THEREOF

THE INTENDED PLOT SIZE OF THIS PLAN IS 280mm IN WIDTH BY 432mm IN HEIGHT (B SIZE) WHEN PLOTTED AT A SCALE OF 1:200

METHOD OF MEASUREMENT:

- TO CENTRELINE OF ALL DEMISING WALLS BETWEEN STRATA LOTS AND ALL STRATA LOT WALLS ADJOINING COMMON AREAS
- TO ONE (1) CENTIMETRE INSIDE OF THE OUTSIDE FACE OF EXTERIOR WALLS
- TO FACE OF CONCRETE WALLS WHERE STRATA LOTS ADJOIN CORE WALLS (IE ELEVATOR, STAIRWELL).

ALL ANGLES ARE 90° OR 45° UNLESS OTHERWISE NOTED

LEGEND

- SL STRATA LOT
- ELEC DENOTES ELECTRICAL
- MECH DENOTES MECHANICAL
- (C) COMMON PROPERTY
- (31) DENOTES LIMITED COMMON PROPERTY FOR STRATA LOT 31 (TYPICAL)

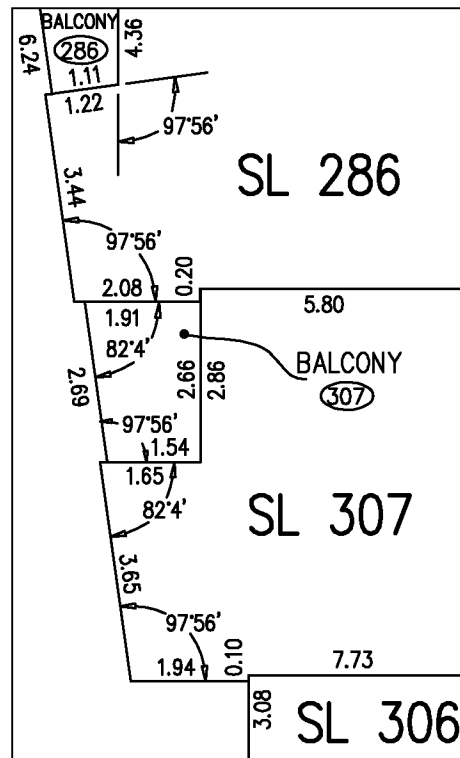

DETAIL NOT TO SCALE

JAMES G. SHAW, BCLS, CLS
 DATE: FEBRUARY 25, 2013
 McELHANNEY ASSOCIATES
 LAND SURVEYING LTD.
 FILE: 2112-07909-24

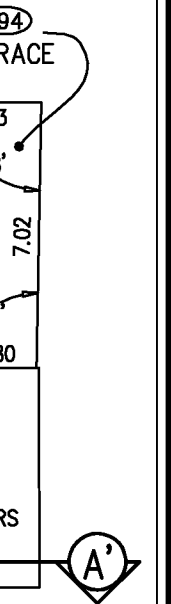
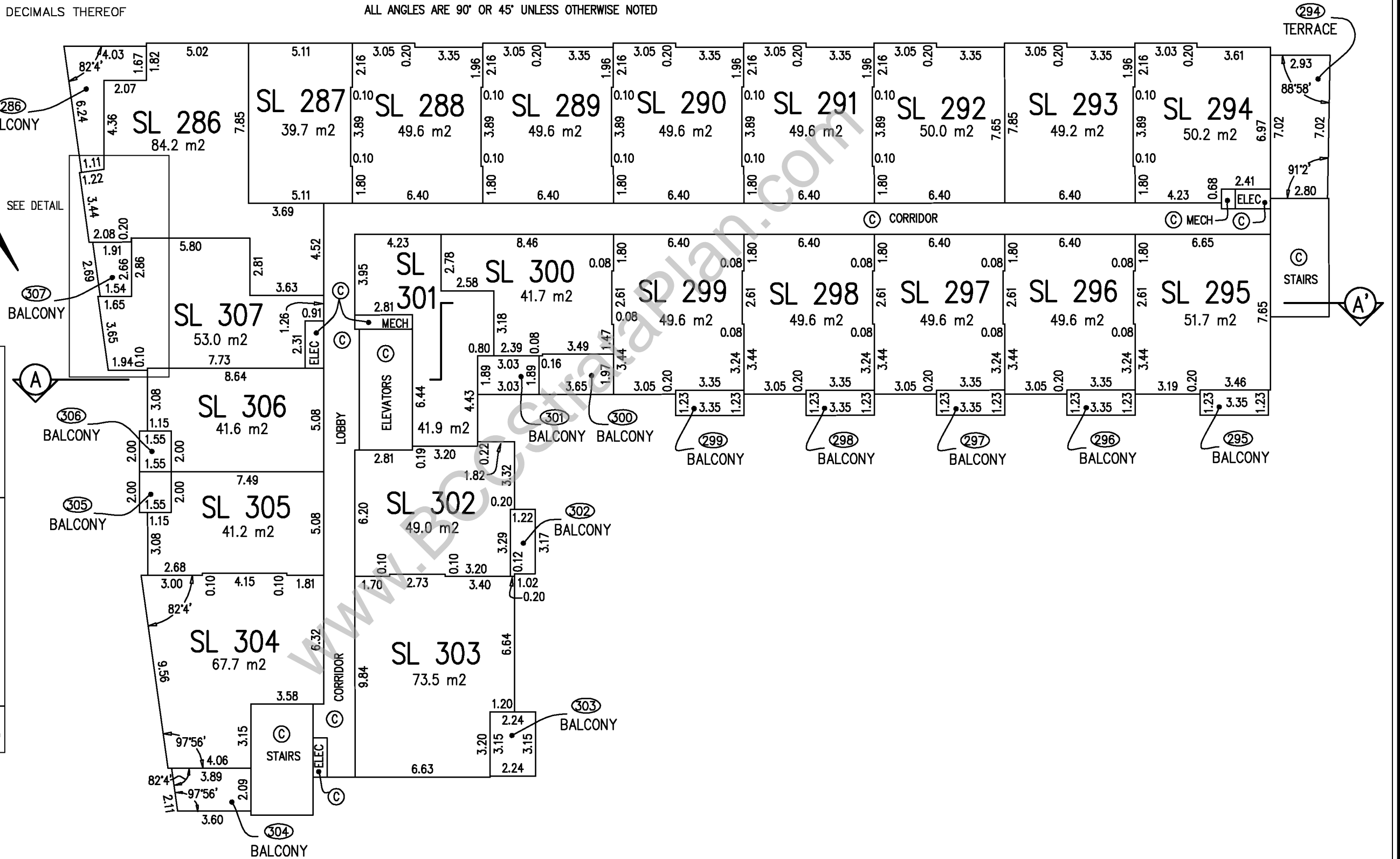

BUILDING 2 LEVEL 7

SHEET 44 OF 48 SHEETS STRATA PLAN EPS1133

SCALE 1 : 200

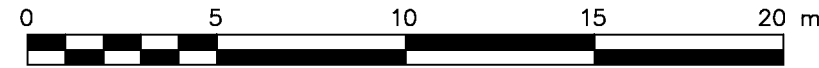

ALL DISTANCES ARE IN METRES AND DECIMALS THEREOF
 THE INTENDED PLOT SIZE OF THIS PLAN IS 280mm IN WIDTH BY 432mm IN HEIGHT (B SIZE) WHEN PLOTTED AT A SCALE OF 1:200

METHOD OF MEASUREMENT:
 -TO CENTRELINE OF ALL DEMISING WALLS BETWEEN STRATA LOTS AND ALL STRATA LOT WALLS ADJOINING COMMON AREAS
 -TO ONE (1) CENTIMETRE INSIDE OF THE OUTSIDE FACE OF EXTERIOR WALLS
 -TO FACE OF CONCRETE WALLS WHERE STRATA LOTS ADJOIN CORE WALLS (IE ELEVATOR, STAIRWELL).

ALL ANGLES ARE 90° OR 45° UNLESS OTHERWISE NOTED

- LEGEND**
- SL STRATA LOT
 - ELEC DENOTES ELECTRICAL
 - MECH DENOTES MECHANICAL
 - (C) COMMON PROPERTY
 - (31) DENOTES LIMITED COMMON PROPERTY FOR STRATA LOT 31 (TYPICAL)

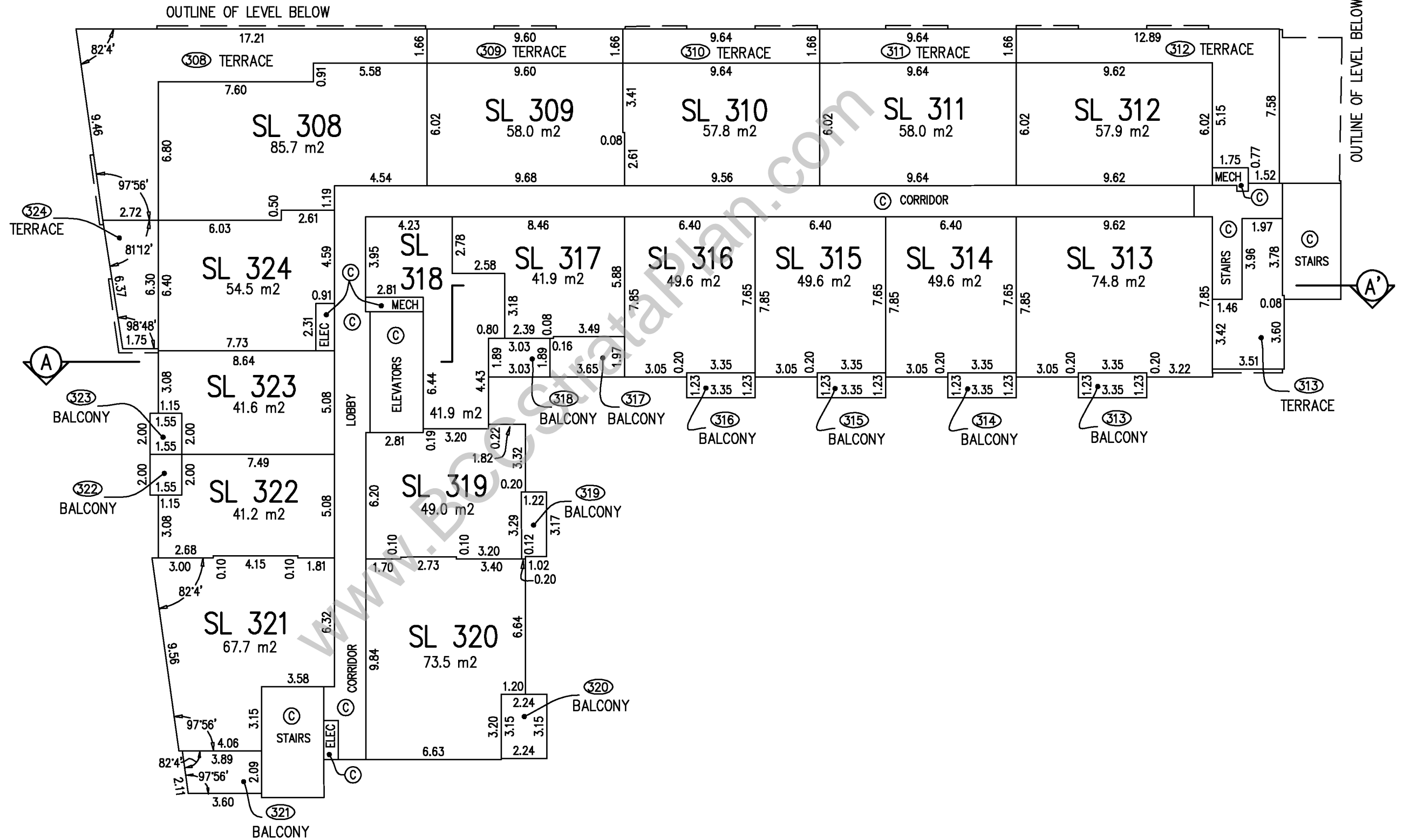

JAMES G. SHAW, BCLS, CLS
 DATE: FEBRUARY 25, 2013
 McELHANNEY ASSOCIATES
 LAND SURVEYING LTD.
 FILE: 2112-07909-24

BUILDING 2 LEVEL 8

SHEET 45 OF 48 SHEETS

STRATA PLAN EPS1133

SCALE 1 : 200

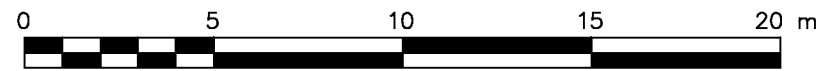

ALL DISTANCES ARE IN METRES AND DECIMALS THEREOF
 THE INTENDED PLOT SIZE OF THIS PLAN IS 280mm IN WIDTH
 BY 432mm IN HEIGHT (B SIZE) WHEN PLOTTED AT A SCALE OF 1:200

METHOD OF MEASUREMENT:

- TO CENTRELINE OF ALL DEMISING WALLS BETWEEN STRATA LOTS AND ALL STRATA LOT WALLS ADJOINING COMMON AREAS
- TO ONE (1) CENTIMETRE INSIDE OF THE OUTSIDE FACE OF EXTERIOR WALLS
- TO FACE OF CONCRETE WALLS WHERE STRATA LOTS ADJOIN CORE WALLS (IE ELEVATOR, STAIRWELL).

ALL ANGLES ARE 90° OR 45° UNLESS OTHERWISE NOTED

OUTLINE OF LEVEL BELOW

LEGEND

- SL — STRATA LOT
- ELEC — DENOTES ELECTRICAL
- Ⓢ — COMMON PROPERTY
- Ⓢ — DENOTES LIMITED COMMON PROPERTY FOR STRATA LOT 31 (TYPICAL)

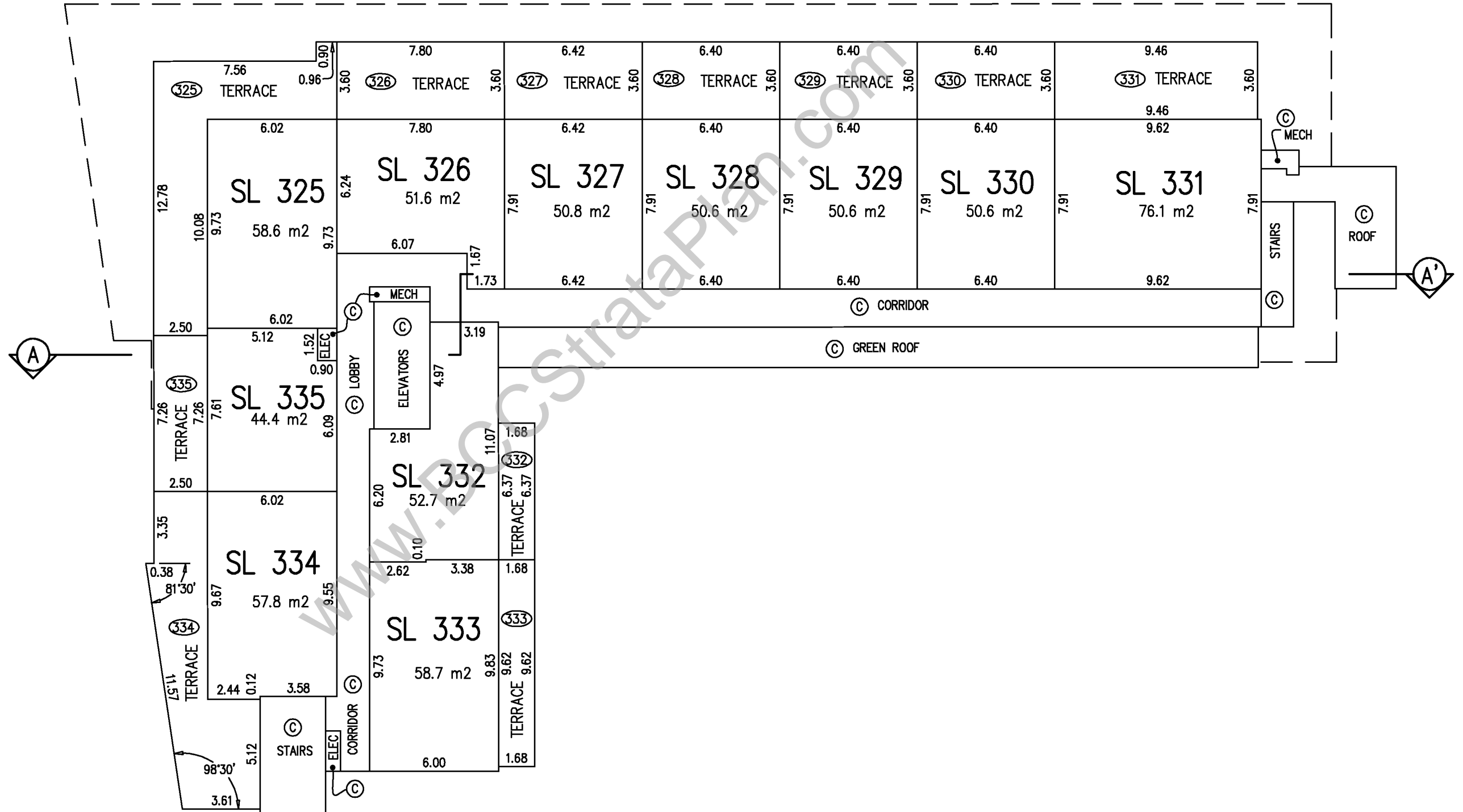

JAMES G. SHAW, BCLS, CLS
 DATE: FEBRUARY 25, 2013
 McELHANNEY ASSOCIATES
 LAND SURVEYING LTD.
 FILE: 2112-07909-24

BUILDING 2 MECHANICAL LEVEL

SHEET 46 OF 48 SHEETS
STRATA PLAN EPS1133

SCALE 1 : 200

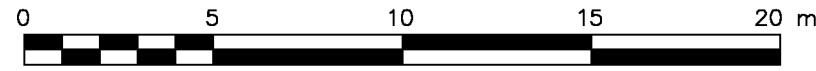

ALL DISTANCES ARE IN METRES AND DECIMALS THEREOF
THE INTENDED PLOT SIZE OF THIS PLAN IS 280mm IN WIDTH
BY 432mm IN HEIGHT (B SIZE) WHEN PLOTTED AT A SCALE OF 1:200

OUTLINE OF LEVEL BELOW

OUTLINE OF LEVEL BELOW

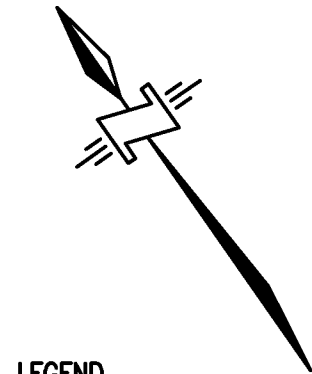

LEGEND
Ⓢ COMMON PROPERTY

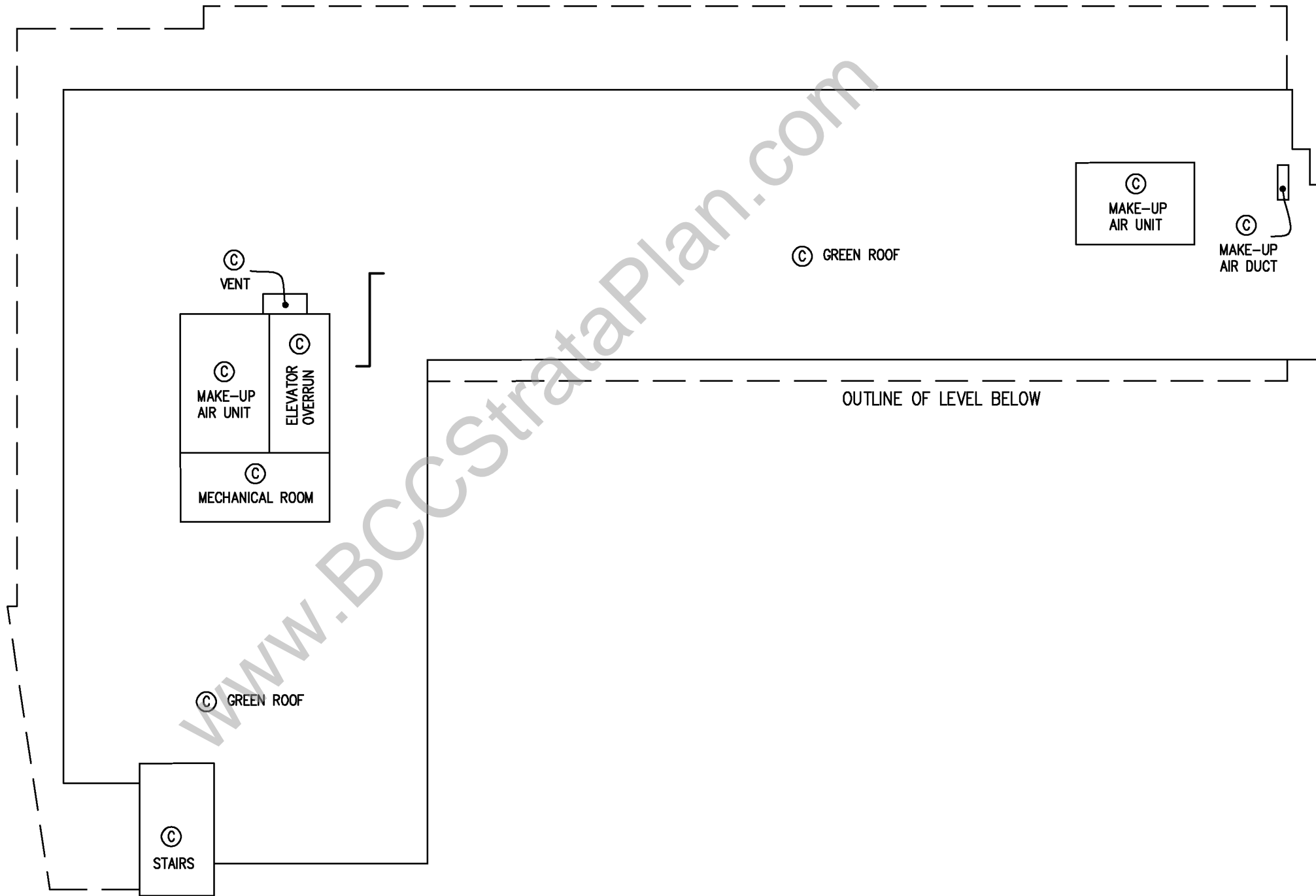
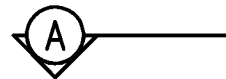

JAMES G. SHAW, BCLS, CLS
DATE: FEBRUARY 25, 2013
McELHANNEY ASSOCIATES
LAND SURVEYING LTD.
FILE: 2112-07909-24

BUILDING 2 ROOF LEVEL

SHEET 47 OF 48 SHEETS
STRATA PLAN EPS1133

SCALE 1 : 200



ALL DISTANCES ARE IN METRES AND DECIMALS THEREOF
 THE INTENDED PLOT SIZE OF THIS PLAN IS 280mm IN WIDTH
 BY 432mm IN HEIGHT (B SIZE) WHEN PLOTTED AT A SCALE OF 1:200

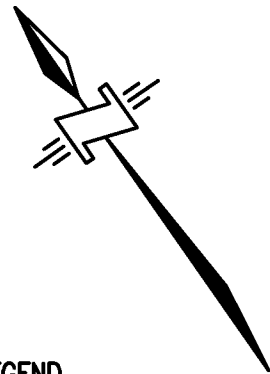

LEGEND

Ⓢ COMMON PROPERTY

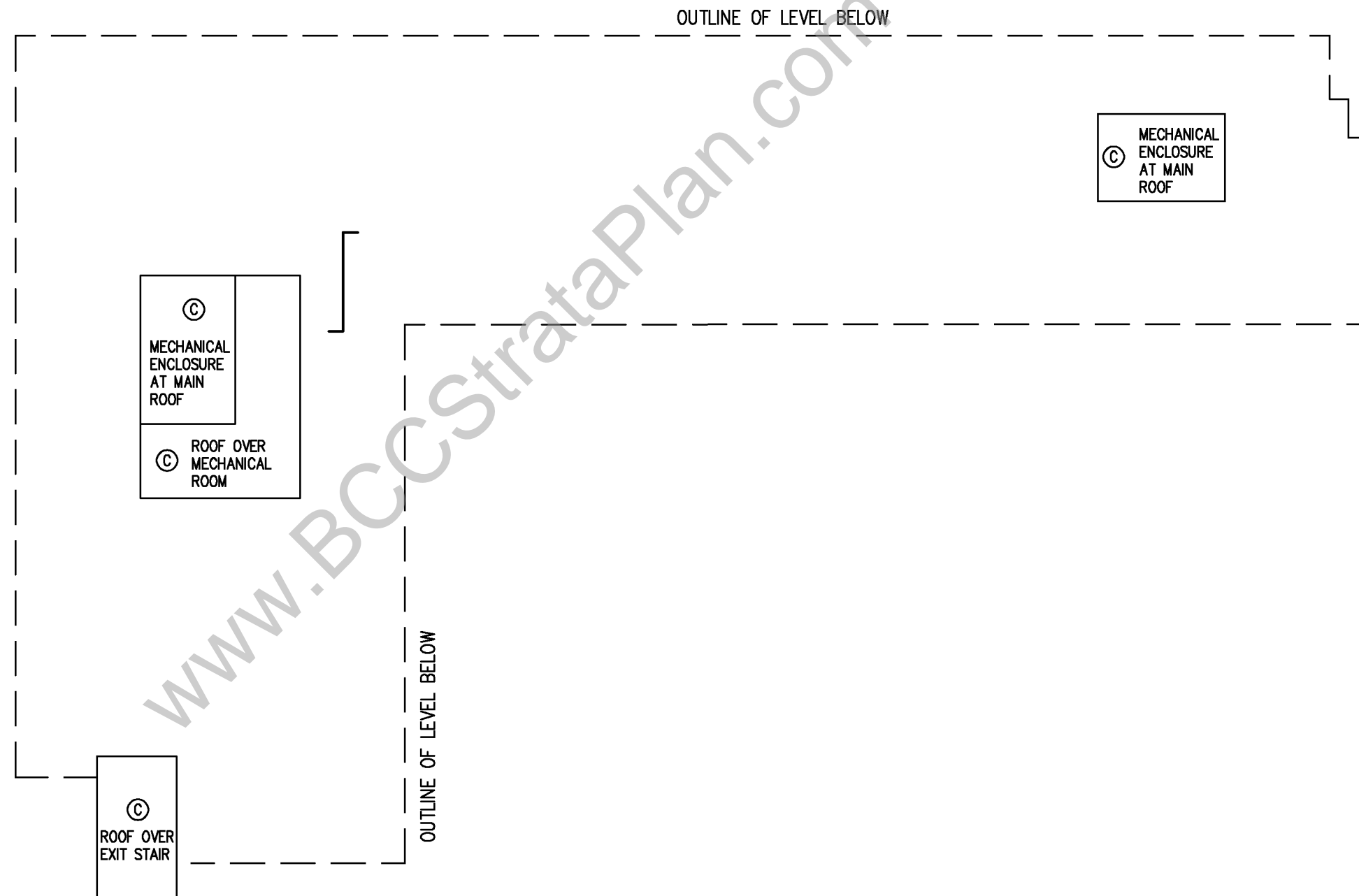
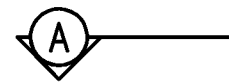

JAMES G. SHAW, BCLS, CLS
 DATE: FEBRUARY 25, 2013
 McELHANNEY ASSOCIATES
 LAND SURVEYING LTD.
 FILE: 2112-07909-24

SECTION A-A'
NOT TO SCALE

SHEET 48 OF 48 SHEETS

STRATA PLAN EPS1133

LEGEND

- ASP _____ DENOTES AIR SPACE PARCEL
- B _____ DENOTES BALCONY
- COMM _____ DENOTES COMMUNICATIONS
- CORR _____ DENOTES CORRIDOR
- ELEC _____ DENOTES ELECTRICAL
- ELEV _____ DENOTES ELEVATOR
- LOB _____ DENOTES LOBBY
- MACH _____ DENOTES MACHINE
- MECH _____ DENOTES MECHANICAL
- SL _____ DENOTES STRATA LOT
- ST _____ DENOTES STAIRS
- T _____ DENOTES TERRACE
- TEL _____ DENOTES TELEPHONE
- VEST _____ DENOTES VESTIBULE
- Ⓢ _____ DENOTES LIMITED COMMON PROPERTY FOR STRATA LOT 31 (TYPICAL)
- Ⓢ _____ DENOTES COMMON PROPERTY

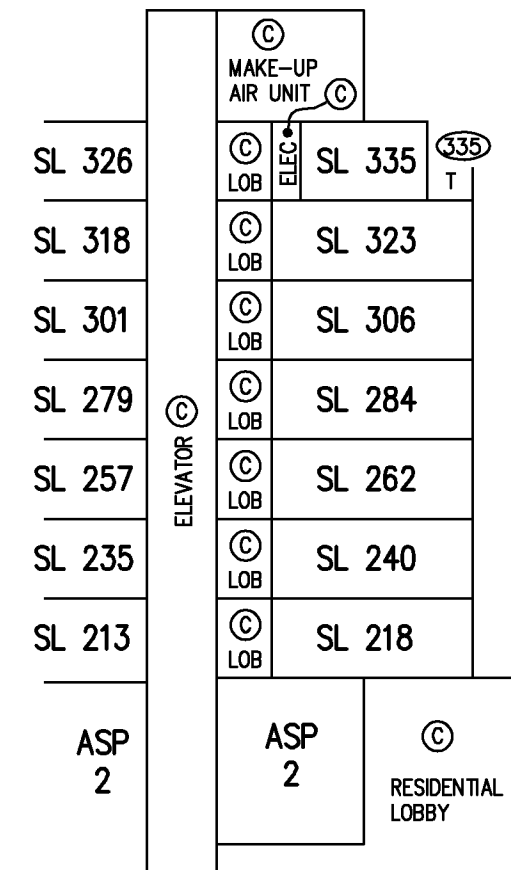

DETAIL
NOT TO SCALE

- GROUND LEVEL MEZZANINE
- GROUND LEVEL UPPER
- GROUND LEVEL
- PARKING LEVEL 1
- PARKING LEVEL 2
- PARKING LEVEL 3
- PARKING LEVEL 4
- PARKING LEVEL 5

STRATA PLAN LMS2320

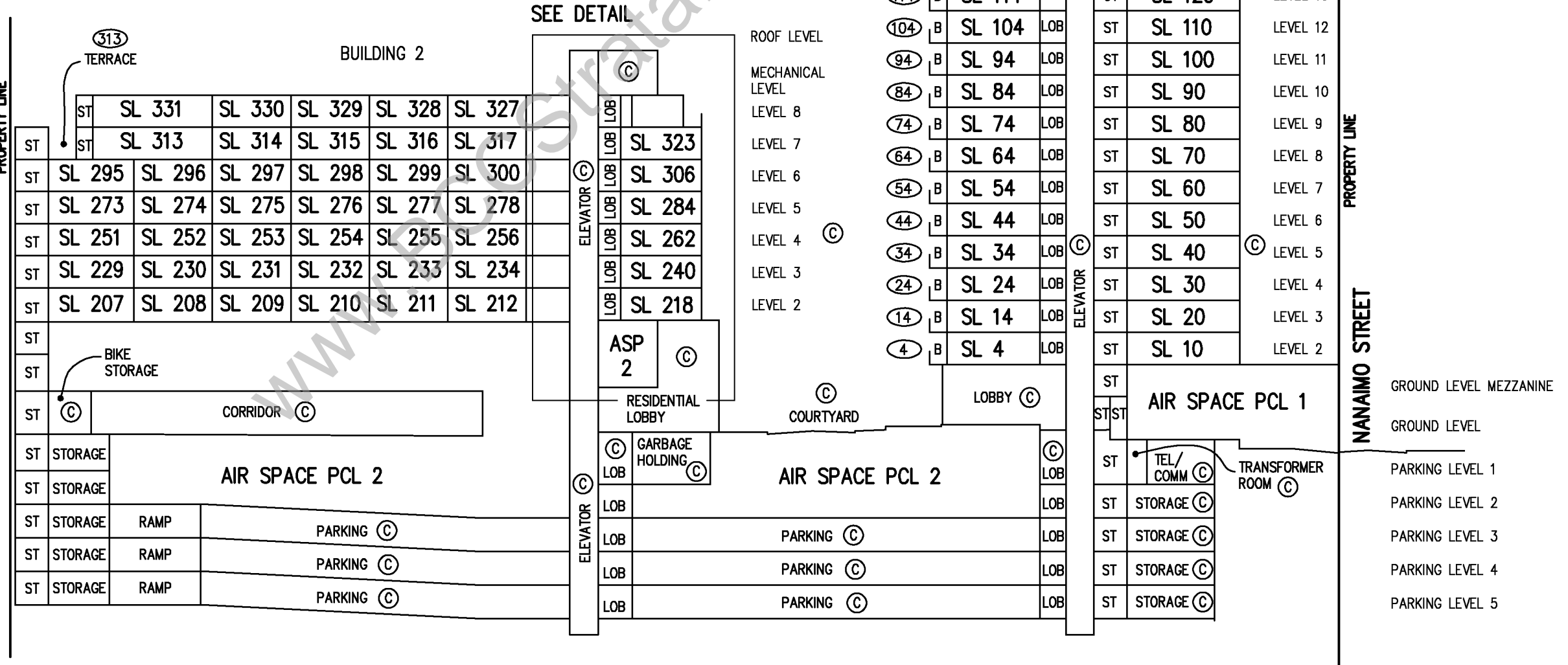

JAMES G. SHAW, BCLS, CLS
DATE: FEBRUARY 25, 2013
McELHANNEY ASSOCIATES
LAND SURVEYING LTD.
FILE: 2112-07909-24