

STRATA PLAN OF LOT 1 BLOCK 108
DISTRICT LOT 37 GROUP 1 NEW
WESTMINSTER DISTRICT PLAN LMP29111

B.C.S. 926.025

CITY OF VANCOUVER

INTEGRATED SURVEY AREA NO 31 VANCOUVER

THIS PLAN SHOWS GROUND LEVEL MEASURED DISTANCES.
PRIOR TO COMPUTATION OF U.T.M. COORDINATES MULTIPLY
BY COMBINED FACTOR OF 0.9993899737
GRID BEARINGS ARE DERIVED FROM CONTROL
MONUMENTS V-1523 AND V-2656

SCALE 1 : 500



ALL DISTANCES ARE IN METRES



STRATA PLAN LMS 3463
DEPOSITED AND REGISTERED IN THE LAND TITLE
OFFICE AT NEW WESTMINSTER, B.C.
THIS 11 DAY OF SEPT 1998

T. Drennell *per*
Deputy REGISTRAR

DM 256364

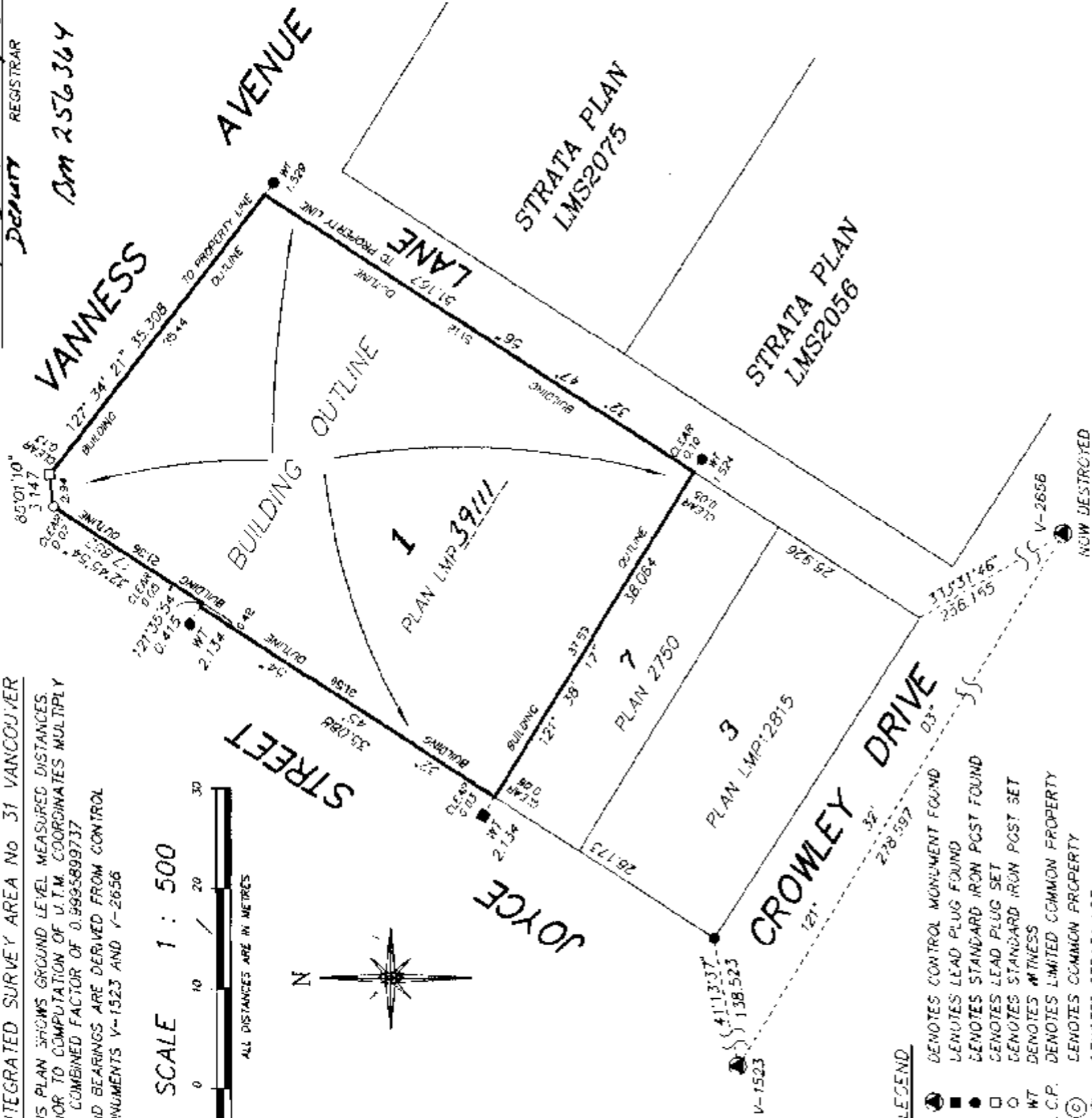

LEGEND

- DENOTES CONTROL MONUMENT FOUND
- DENOTES LEAD PLUG FOUND
- DENOTES STANDARD IRON POST FOUND
- DENOTES LEAD PLUG SET
- DENOTES STANDARD IRON POST SET
- WT DENOTES WITNESS
- L.C.P. DENOTES LIMITED COMMON PROPERTY
- ⊙ DENOTES COMMON PROPERTY
- SL DENOTES STRATA LOT
- A DENOTES AREA
- m² DENOTES SQUARE METRES
- sqft DENOTES SQUARE FEET
- (P) DENOTES PATIO, LCP APPURTENANT TO ADJACENT STRATA LOT
- (B) DENOTES BALCONY, LCP APPURTENANT TO ADJACENT STRATA LOT
- (B) DENOTES ENCLOSED BALCONY
- (P) DENOTES ENCLOSED PATIO
- (T) DENOTES TERRACE, LCP APPURTENANT TO ADJACENT STRATA LOT
- ⌋ DENOTES CENTRELINE OF WALLS
- (T) DENOTES STRATA LOT SIDE OF WALL
- (B) DENOTES BUILDING LINE
- (C) DENOTES GLASS LINE
- (N) DENOTES NO WALL
- D/A DENOTES OVER ALL
- LCP30 DENOTES LIMITED COMMON PROPERTY (TYPICAL) FOR EXCLUSIVE USE OF STRATA LOT 30
- STRATA LOT AREAS INCLUDE AREAS OF ENCLOSED BALCONIES AND ENCLOSED PATIOS.

THE ADDRESS FOR THE SERVICE OF DOCUMENTS

ON THE STRATA CORPORATION IS
THE OWNERS, STRATA PLAN LMS 3463
5th FLOOR 1190 HORNBY STREET,
VANCOUVER, B.C. V6Z-2K5

CIVIC ADDRESS OF PROPERTY:
2438 VANNESSE AVENUE,
VANCOUVER, B.C.

I, DIETER SOKUP, OF SURREY, A BRITISH
COLUMBIA LAND SURVEYOR, HEREBY CERTIFY
THAT THE BUILDING ERECTED ON THE
PARCEL DESCRIBED ABOVE IS WHOLLY WITHIN
THE EXTERNAL BOUNDARIES OF THAT PARCEL
DATED THIS 27th DAY OF AUGUST, 1998

I, DIETER SOKUP, OF SURREY, A BRITISH
COLUMBIA LAND SURVEYOR, HEREBY CERTIFY
THAT THE BUILDING SHOWN IN THIS STRATA
PLAN HAS NOT AS OF THE 21st DAY OF
AUGUST, 1998 BEEN PREVIOUSLY OCCUPIED
DATED THIS 21st DAY OF AUGUST, 1998

[Signature]
B.C.L.S.

SOKUP LAND SURVEYING INC
201 - 848 162nd STREET
SURREY, B.C. V4N 1B4
TEL 597 6161 FAX 597 0259
FILE: V2668\LOTTI-S1

THIS PLAN LIES WITHIN THE GREATER VANCOUVER REGIONAL DISTRICT
INDIVIDUAL BOUNDARY DESIGNATION
FOR COMMERCIAL STRATA LOTS SEE LEGEND FOR
STRA TA LOT BOUNDARY DEFINITION:
CENTRELINE OF WALLS FOR ALL RESIDENTIAL STRATA LOTS.
VANCOUVER, B.C.

STRATA PLAN LMS 3463

CONDOMINIUM ACT

LOT No.	SHEET No.	FORM 1	FORM 2	FORM 3
		SCHEDULE OF UNIT ENTITLEMENT UNIT ENTITLEMENT	SCHEDULE OF INTEREST UPON DESTRUCTION INTEREST UPON DESTRUCTION	SCHEDULE OF VOTING RIGHTS NUMBER OF VOTES
1	16	567	590	1
2	16	571	590	1
3	16	913	1045	1
4	16	536	581	1
5	16	728	852	1
6	16	953	1176	1
7	16	562	581	1
8	16	571	581	1
9	16	600	607	1
10	16	594	594	1
11	16	510	559	1
12	16	511	559	1
13	16	557	638	1
14	16	412	432	1
15	16	866	918	1
16	15	562	577	1
17	15	573	577	1
18	15	546	577	1
19	15	365	348	1
20	15	574	559	1
21	15	533	550	1
22	15	507	550	1
23	15	731	773	1
24	15	399	428	1
25	15	866	909	1
26	15	562	568	1
27	15	573	568	1
28	15	546	568	1
29	15	365	345	1
30	15	574	550	1
31	15	533	542	1
32	15	507	546	1
33	15	731	765	1
34	15	399	424	1
35	15	866	891	1
36	14	562	564	1
37	14	573	564	1
38	14	546	584	1
39	14	365	341	1
40	14	574	546	1
41	14	533	537	1
42	14	507	537	1
43	14	731	743	1
44	14	399	419	1
45	14	866	883	1
46	14	562	555	1
47	14	573	555	1
48	14	546	555	1
49	14	365	336	1
50	14	574	537	1
51	14	533	529	1
52	14	507	533	1
53	14	731	734	1
54	14	399	415	1
55	14	866	874	1
56	13	562	550	1
57	13	573	550	1
58	13	546	550	1
59	13	365	332	1
60	13	574	533	1
61	13	533	524	1
62	13	507	524	1
63	13	731	725	1
64	13	399	411	1
65	13	866	865	1
66	13	562	542	1
67	13	573	542	1
68	13	546	542	1
69	13	365	327	1
70	13	574	524	1
71	13	533	515	1
72	13	507	520	1
73	13	731	717	1
74	13	399	406	1
75	13	866	857	1
76	12	562	537	1
77	12	573	537	1
78	12	546	537	1
79	12	365	323	1
80	12	574	520	1
81	12	533	511	1
82	12	507	511	1

DATED THIS 10th DAY OF AUGUST, 1998

[Signature] B.C.L.S.
File # 12608\LOT1-51

STRATA PLAN LMS 3463

CONDOMINIUM ACT

LOT No.	SHEET No.	FORM 1	FORM 2	FORM 3
		SCHEDULE OF UNIT ENTITLEMENT UNIT ENTITLEMENT	SCHEDULE OF INTEREST UPON DESTRUCTION INTEREST UPON DESTRUCTION	SCHEDULE OF VOTING RIGHTS NUMBER OF VOTES
83	12	731	708	1
84	12	399	402	1
85	12	868	848	1
86	12	562	529	1
87	12	573	529	1
88	12	546	529	1
89	12	365	319	1
90	12	574	511	1
91	12	513	502	1
92	12	507	507	1
93	12	731	699	1
94	12	399	397	1
95	12	866	839	1
96	11	562	524	1
97	11	573	524	1
98	11	546	520	1
99	11	365	314	1
100	11	574	507	1
101	11	513	498	1
102	11	731	690	1
103	11	399	393	1
104	11	866	830	1
105	11	576	515	1
106	11	570	520	1
107	11	590	511	1
108	11	365	314	1
109	11	500	507	1
110	10	576	511	1
111	10	570	511	1
112	10	550	498	1
113	10	365	310	1
114	10	866	838	1
115	10	576	507	1
116	10	570	502	1
117	10	550	459	1
118	10	365	310	1
119	10	600	494	1
120	9	576	502	1
121	9	570	494	1
122	9	500	487	1
123	9	365	306	1
124	9	600	489	1
125	9	812	806	1
126	9	366	306	1
127	9	574	481	1
128	21	1258	1085	23
129	21	728	1054	13
130	21	919	574	15
131	21	597	563	17
132	21	1099	914	20
133	20	1289	1565	24
134	20	948	683	18
135	20	2026	1563	37
136	20	1809	2027	33
137	20	4414	2104	40
138	19	1833	1730	34
139	19	1668	1437	31
140	19	1790	1668	33
141	19	2231	1998	47
142	19	2245	2076	41
143	19	1477	1544	27
144	18	801	845	15
145	18	1211	1202	22
146	18	1210	1202	22
147	18	1488	1650	27
148	18	2055	2029	38
AGGREGATE		103279	100000	184

DATED THIS 10th DAY OF
AUGUST, 1998
[Signature]
FILE # 268\LOTT-51

STRATA PLAN LMS 3463

STATUTORY DECLARATION

I / WE THE UNDERSIGNED DO SOLEMNLY DECLARE THAT
[1] I / WE THE UNDERSIGNED AM / ARE THE OWNER - DEVELOPER OR (IN THE ALTERNATE)
THE DULY AUTHORIZED AGENT OF THE OWNER - DEVELOPER,
[2] THE STRATA PLAN IS FOR RESIDENTIAL AND COMMERCIAL USE
I / WE MAKE THIS SOLEMN DECLARATION CONSCIENTIOUSLY BELIEVING IT TO BE TRUE AND
KNOWING THAT IT IS OF THE SAME FORCE AND EFFECT AS IF MADE UNDER OATH.

DECLARED BEFORE ME AT Vancouver

IN THE PROVINCE OF BRITISH COLUMBIA
THIS 25th DAY OF August, 1998

NAME: DAVID R. PODMORE DAVID R. PODMORE
PRESIDENT & CHIEF EXECUTIVE OFFICER

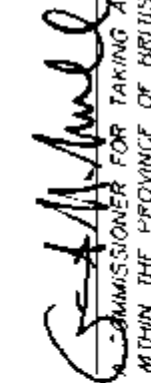

GAVIN MARSHALL
Barrister & Solicitor
1300 - 777 DUNSMUIR STREET
VANCOUVER, B.C. V7Y 1R2
(604) 643-8888
COMMISSIONER FOR TAKING AFFIDAVITS
WITHIN THE PROVINCE OF BRITISH COLUMBIA

GAVIN MARSHALL
Barrister & Solicitor
1300 - 777 DUNSMUIR STREET
VANCOUVER, B.C. V7Y 1K2
(604) 643-5955

ACCEPTED AS TO FORMS 1, 2 & 3
DATED THIS 25th DAY OF SEPT., 1998

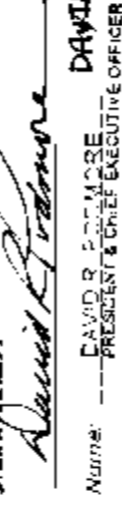

FOR SUPERINTENDENT OF REAL ESTATE

GARNER
377417 BRITISH COLUMBIA LTD.
(INC NO 377417) BY HIS AUTHORIZED
SIGNATURES:

NAME: DAVID R. PODMORE DAVID R. PODMORE
PRESIDENT & CHIEF EXECUTIVE OFFICER

NAME: LIONEL T. WAZNY LIONEL T. WAZNY
SECRETARY

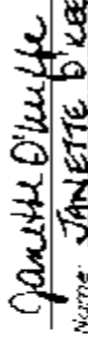
WITNESS:

NAME: JANETTE O'KEEFE
94A FLE - 1190 HORNBY ST. VAN. BC
ADDRESS OF WITNESS
DEVELOPMENT MANAGER
OCCUPATION OF WITNESS

MORTGAGEE:
BANK OF AMERICA CANADA
AUTHORIZED SIGNATORY

NAME: DANIEL M.R. STEWART
DANIEL M.R. STEWART
VICE PRESIDENT
BANK OF AMERICA CANADA

WITNESS:

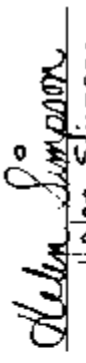
NAME: Helen Simpson
#574-1055 DUNSMUIR ST. VAN. BC. V7X 1L3
ADDRESS OF WITNESS
Loan Administration Officer
OCCUPATION OF WITNESS

OFFICER TO FORGIVE:

5952N BRITISH COLUMBIA INC. (INC. NO. 5952N)
BY HIS AUTHORIZED SIGNATURES:

NAME: ALLAN T. GJERDES ALLAN T. GJERDES

NAME: LIONEL T. WAZNY LIONEL T. WAZNY
SECRETARY

WITNESS:

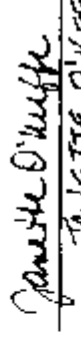
NAME: JANETTE O'KEEFE
94A FLE - 1190 HORNBY ST. VAN. BC
ADDRESS OF WITNESS
DEVELOPMENT MANAGER
OCCUPATION OF WITNESS

DATED THIS 10th DAY OF
AUGUST, 1998

 B.C.L.S.
FILE # 2685\1071-57

FLOOR PLANS

STRATA PLAN LMS3463

SCALE 1 : 200

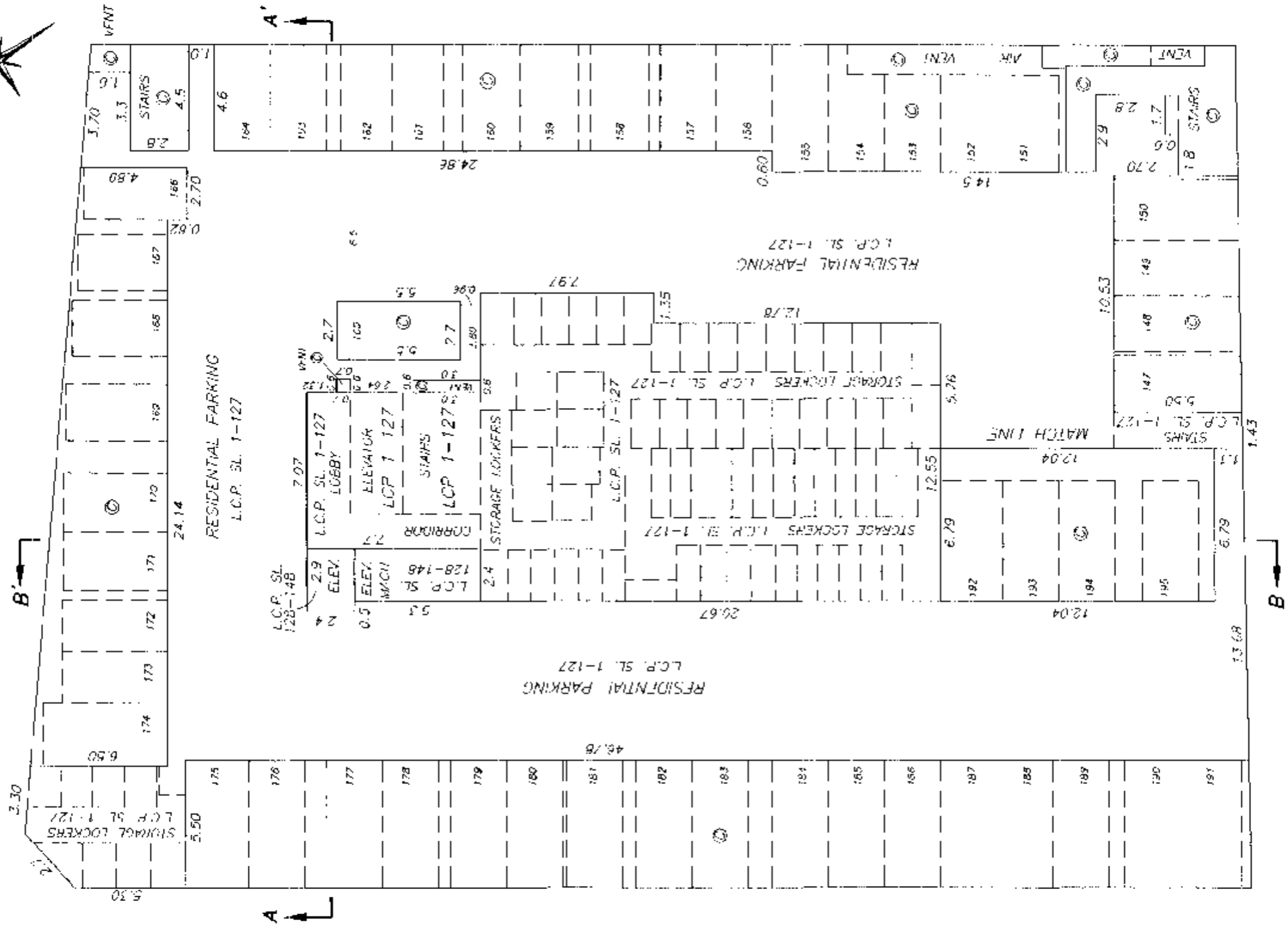

P4 LEVEL

190 DENOTES PARKING SPALL (TYPICAL)

DATED THIS 16TH DAY OF AUGUST, 1998

[Signature]
B.C.L.S.

FLOOR PLANS

STRATA PLAN LMS3463

SCALE 1 : 200



ALL DISTANCES ARE IN METRES

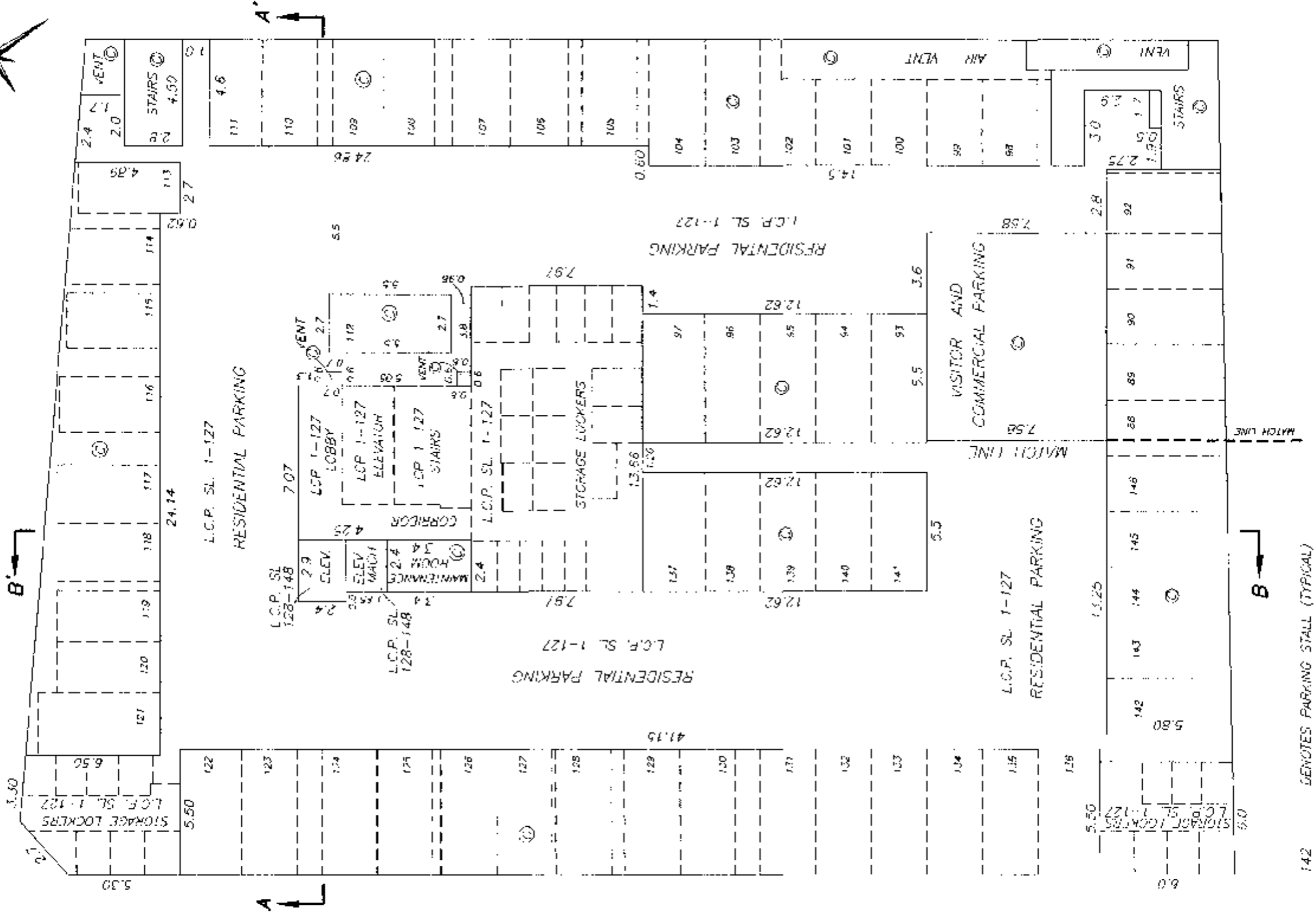

142 GENOTES PARKING STALL (TYPICAL)

P3 LEVEL

DATED THIS 10TH DAY OF AUGUST, 1998
PREPARED BY B.C.L.S.

FLOOR PLANS

STRATA PLAN LMS3463

SCALE 1 : 200



ALL DISTANCES ARE IN METRES

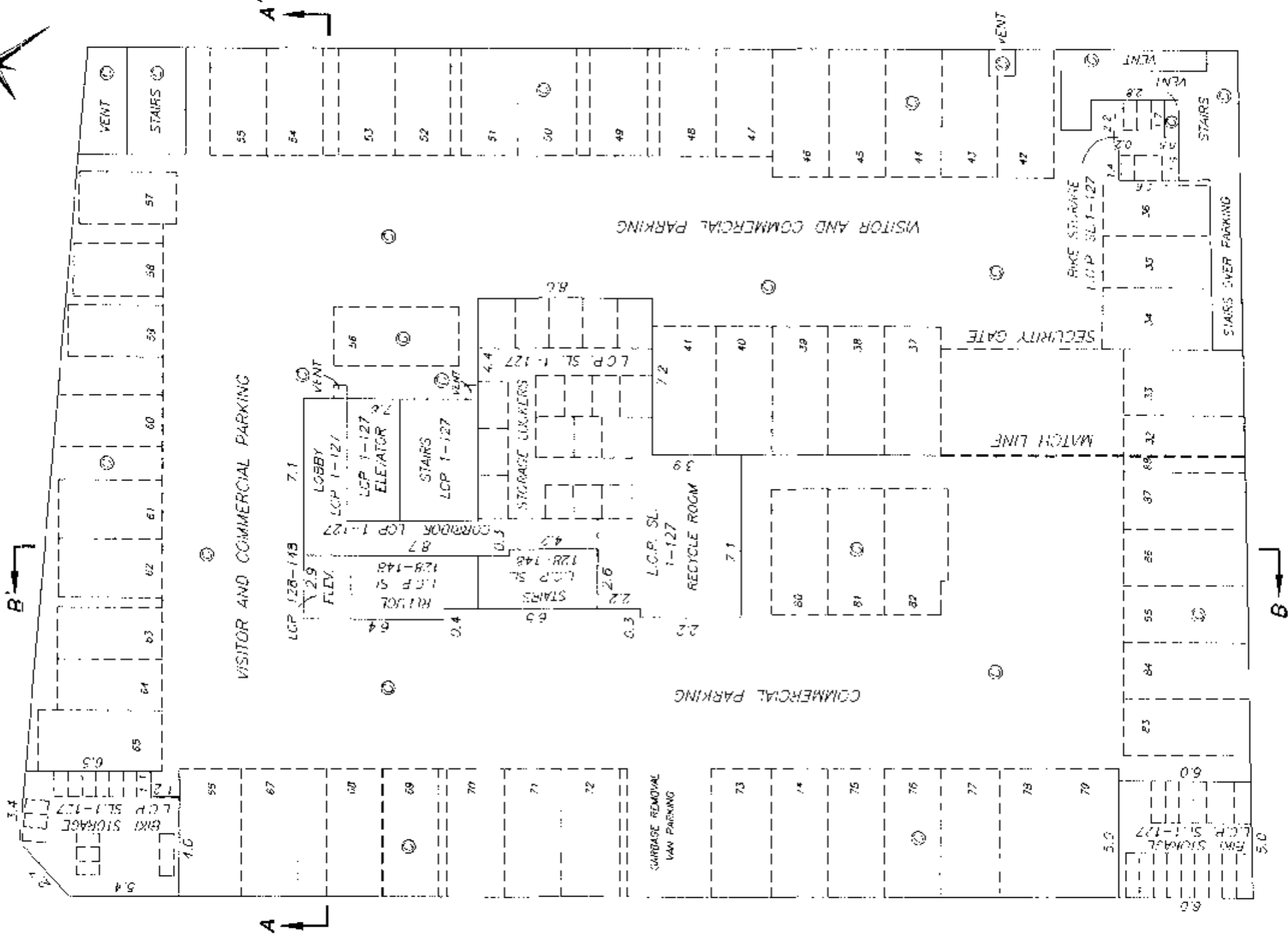

23 DENOTES PARKING STALL (TYPICAL)

P2 LEVEL

DATED THIS 10th DAY OF AUGUST, 1998
B.C.L.S.
1/2008/P2

FLOOR PLANS

STRATA PLAN LMS3463

SCALE 1 : 200



ALL DISTANCES ARE IN METRES



B' →

A' →

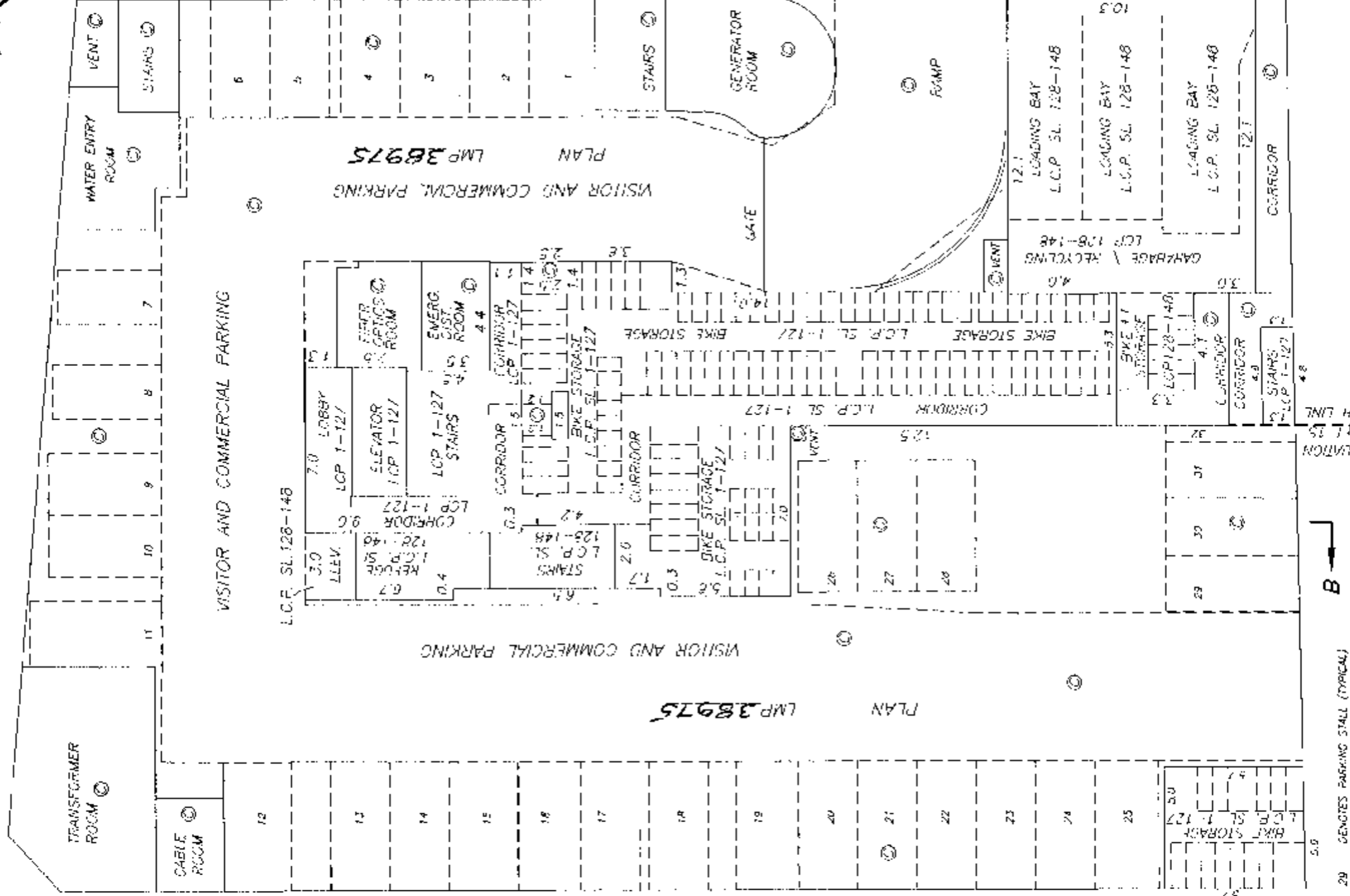

29 DENOTES PARKING STALL (TYPICAL)

FOR CONTINUATION
SEE SHEET 25
MATCH LINE

P1 LEVEL

DATED THIS 10th DAY OF
AUGUST, 1998

[Signature]
P.E. 12208191
O.C.S.

STRATA PLAN LMS3463

FLOOR PLANS

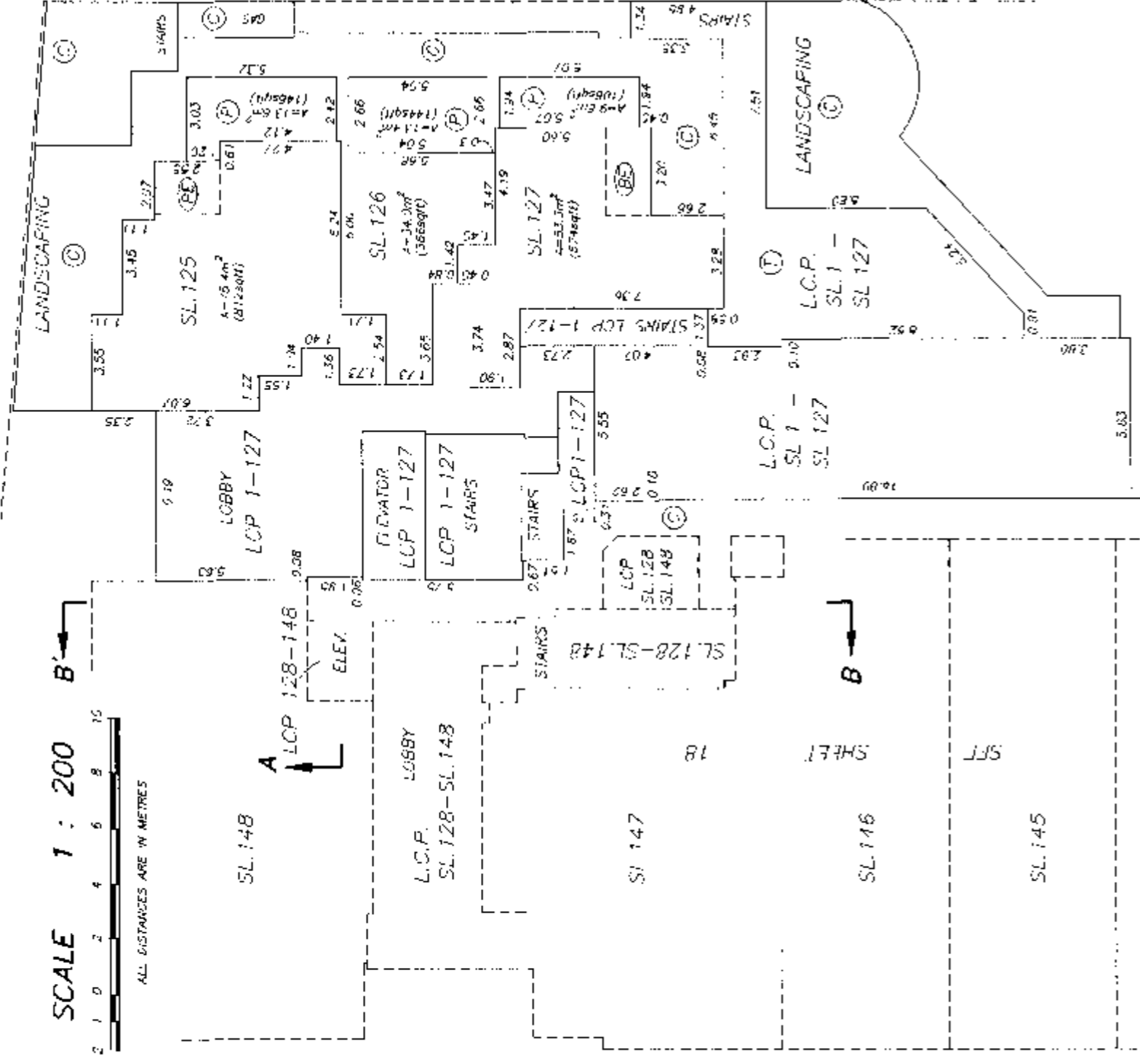

1st LEVEL RESIDENTIAL

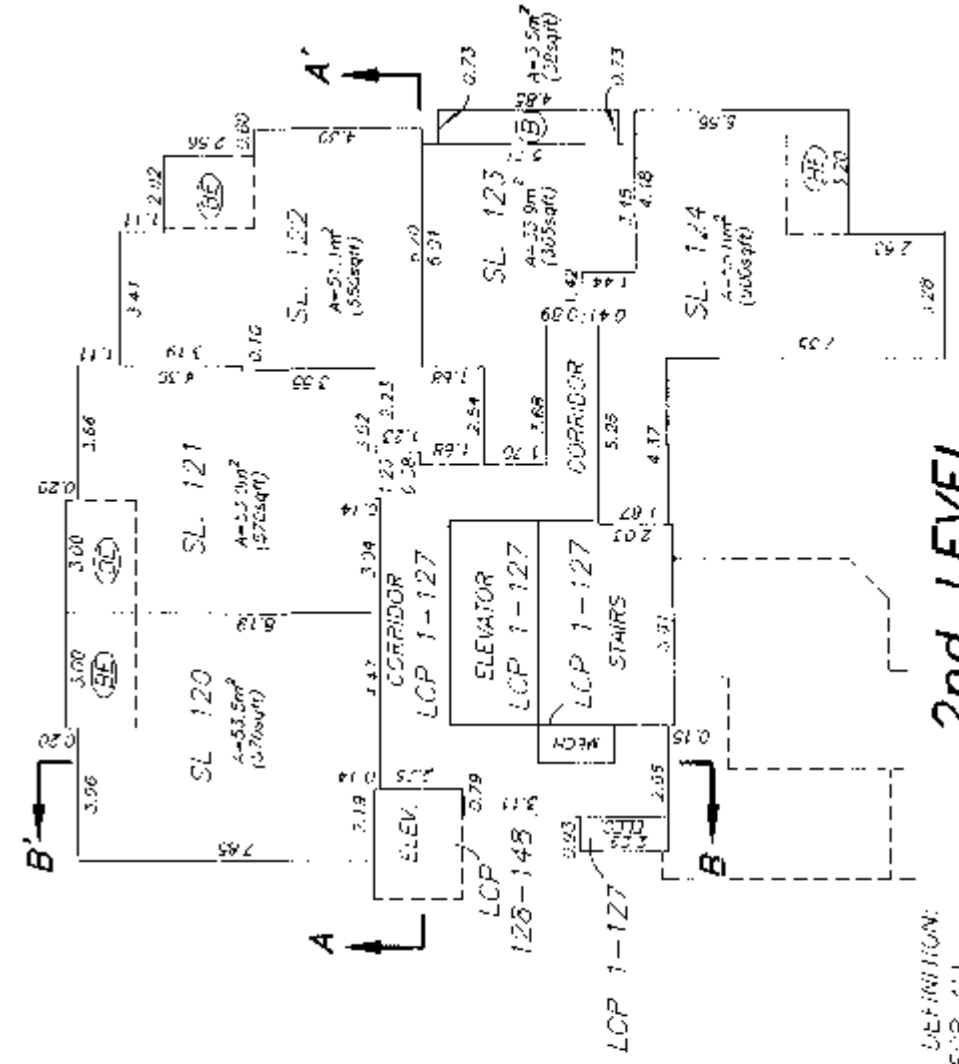

2nd LEVEL RESIDENTIAL

STRATA LOT BOUNDARY DEFINITION:
CENTRAL WALLS FOR ALL
RESIDENTIAL STRATA LOTS

DATED THIS 11th DAY OF
AUGUST, 1998

[Signature] B.C.L.S.
FILE: LMS3463/C 571

FLOOR PLANS

STRATA PLAN LMS 3463

SCALE 1 : 200

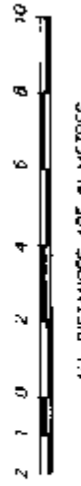

ALL DISTANCES ARE IN METRES

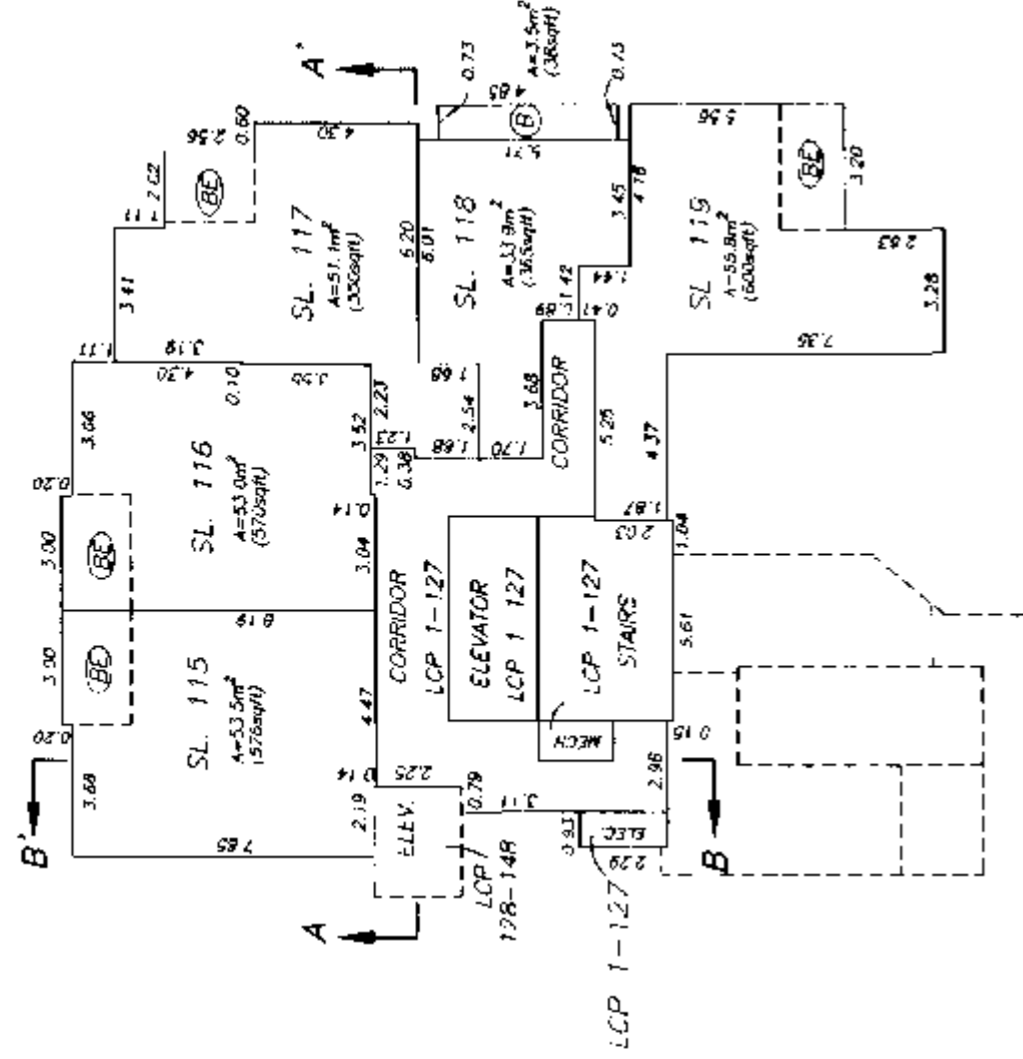

3rd LEVEL
RESIDENTIAL

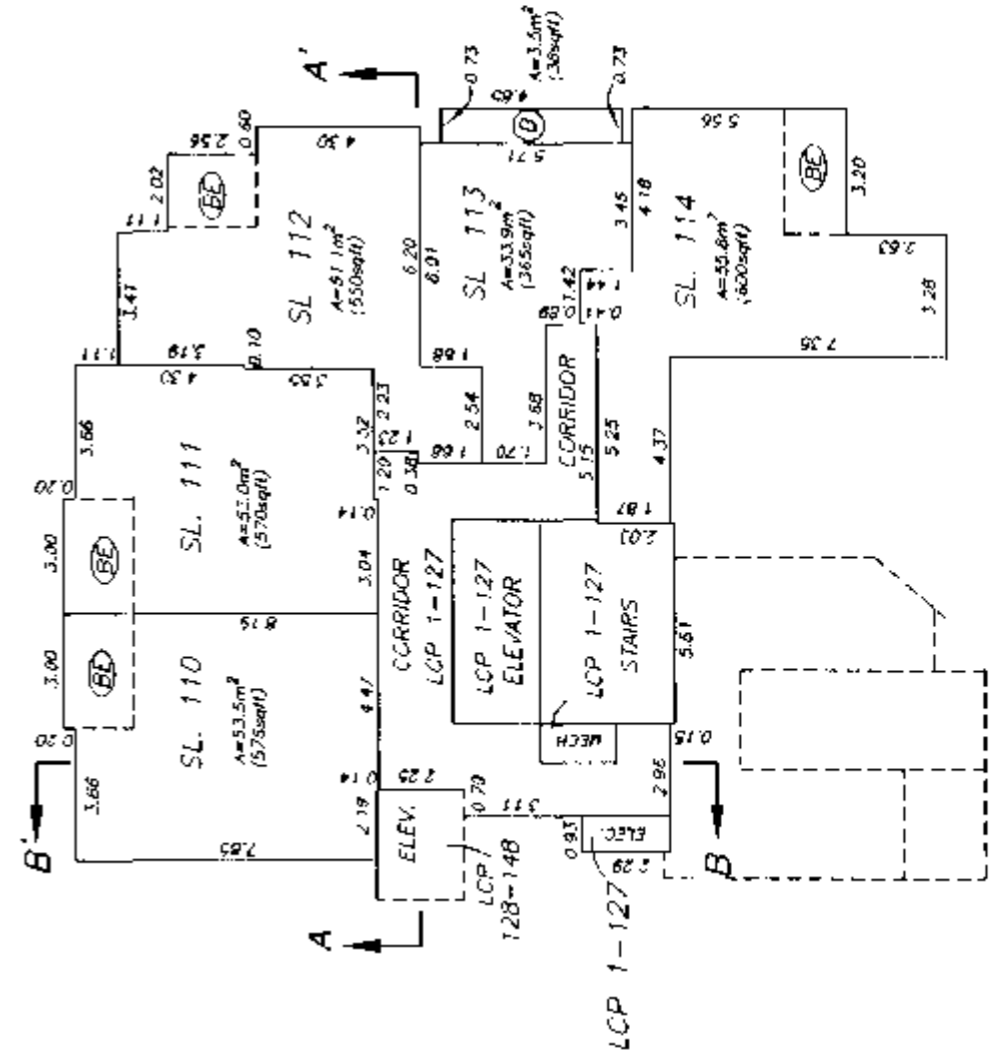

4th LEVEL
RESIDENTIAL

STRATA LOT BOUNDARY DEFINITION:
CENTRELINE OF WALLS FOR ALL
RESIDENTIAL STRATA LOTS

DATED THIS 10th DAY OF
AUGUST, 1998

[Signature]
B.C.L.S.
File: \2608\2-5TH

FLOOR PLANS

STRATA PLAN LMS 3463

SCALE 1 : 200



ALL DISTANCES ARE IN METRES

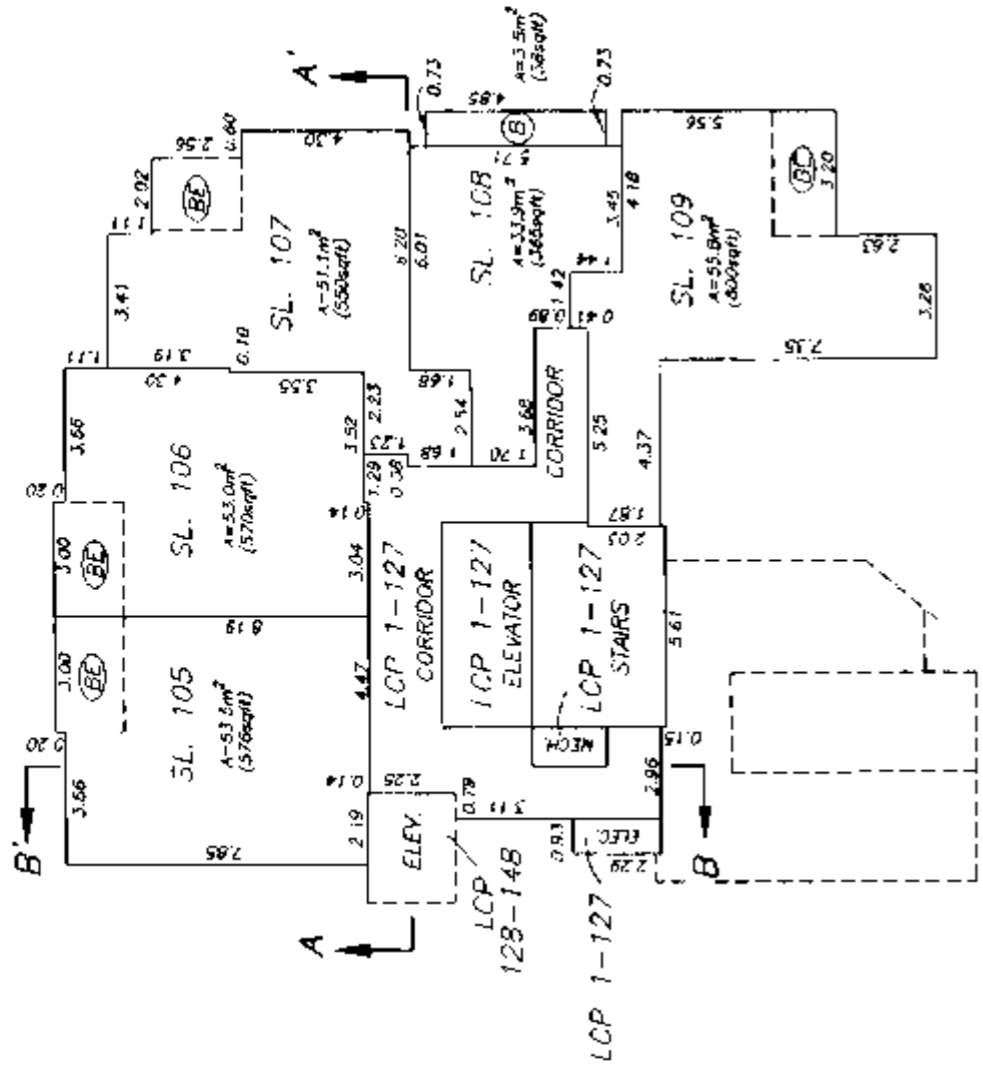

5th LEVEL
RESIDENTIAL

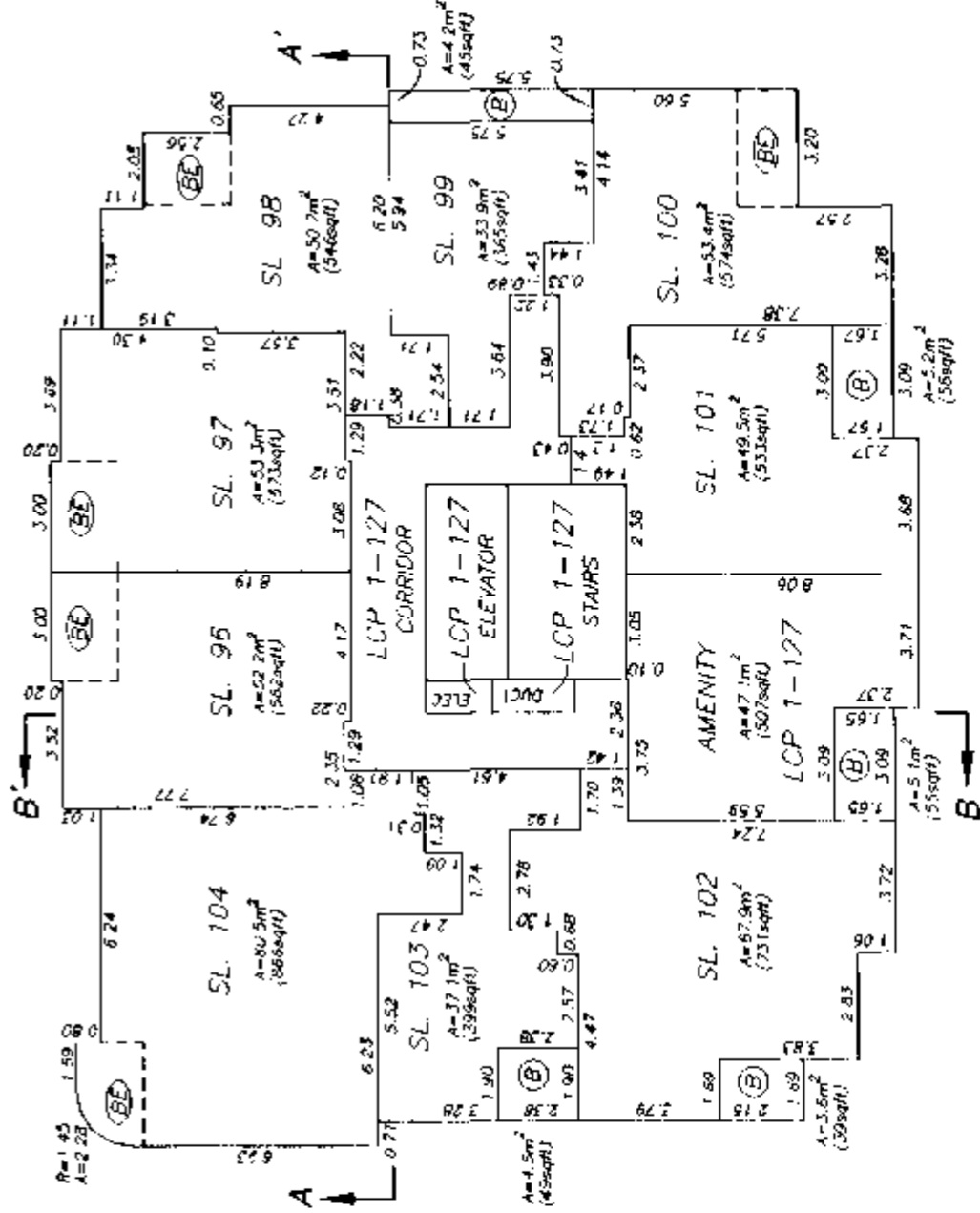

6th LEVEL
RESIDENTIAL

DATED THIS 10th DAY OF
AUGUST, 1998
B.C.L.S.

STRATA LOT BOUNDARY DEFINITION:
CENTRELINE OF WALLS FOR ALL RESIDENTIAL STRATA LOTS

FILE: 2008\6-14TH

FLOOR PLANS

STRATA PLAN LMS 3463

SCALE 1 : 200



ALL DISTANCES ARE IN METRES

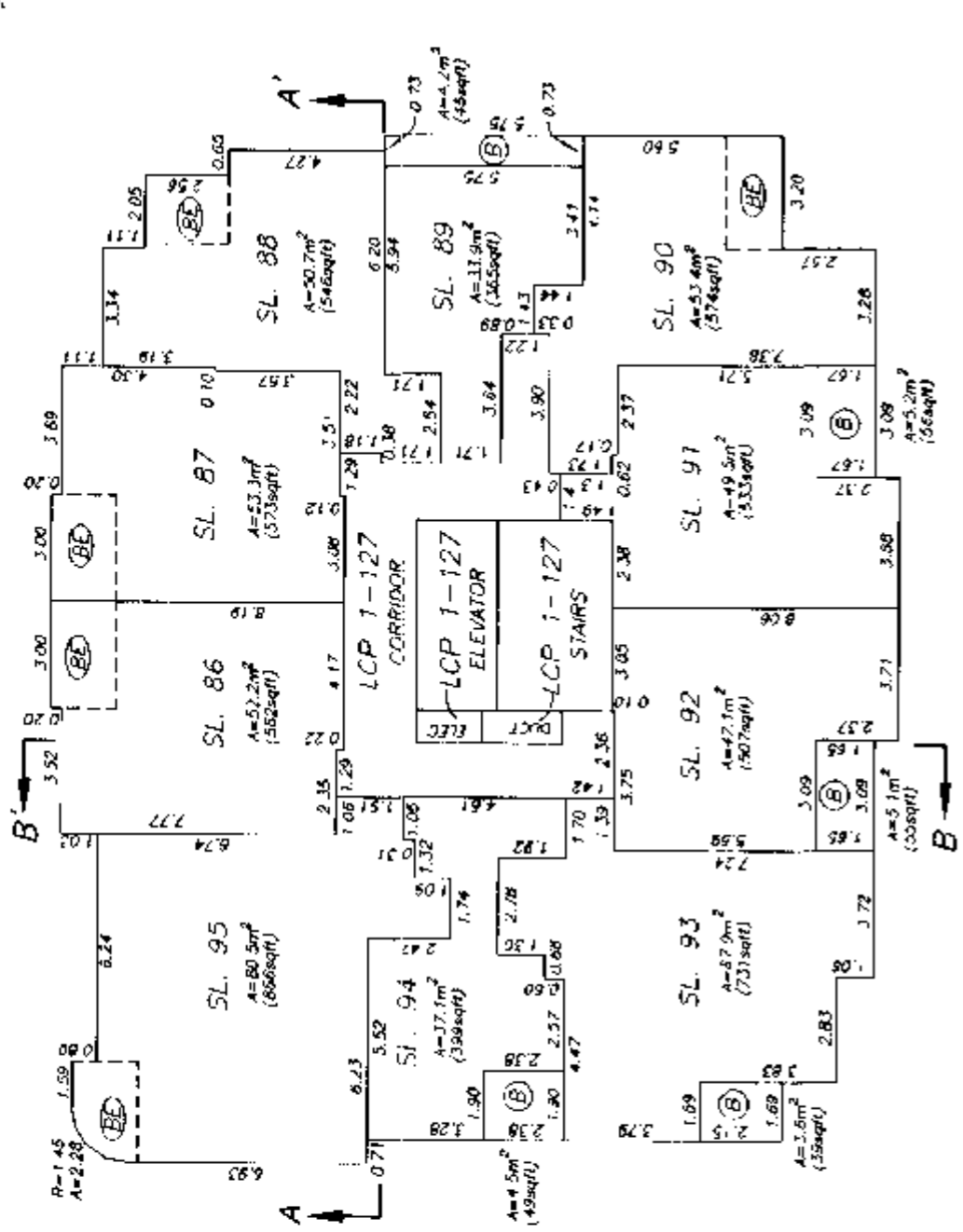

7th LEVEL RESIDENTIAL

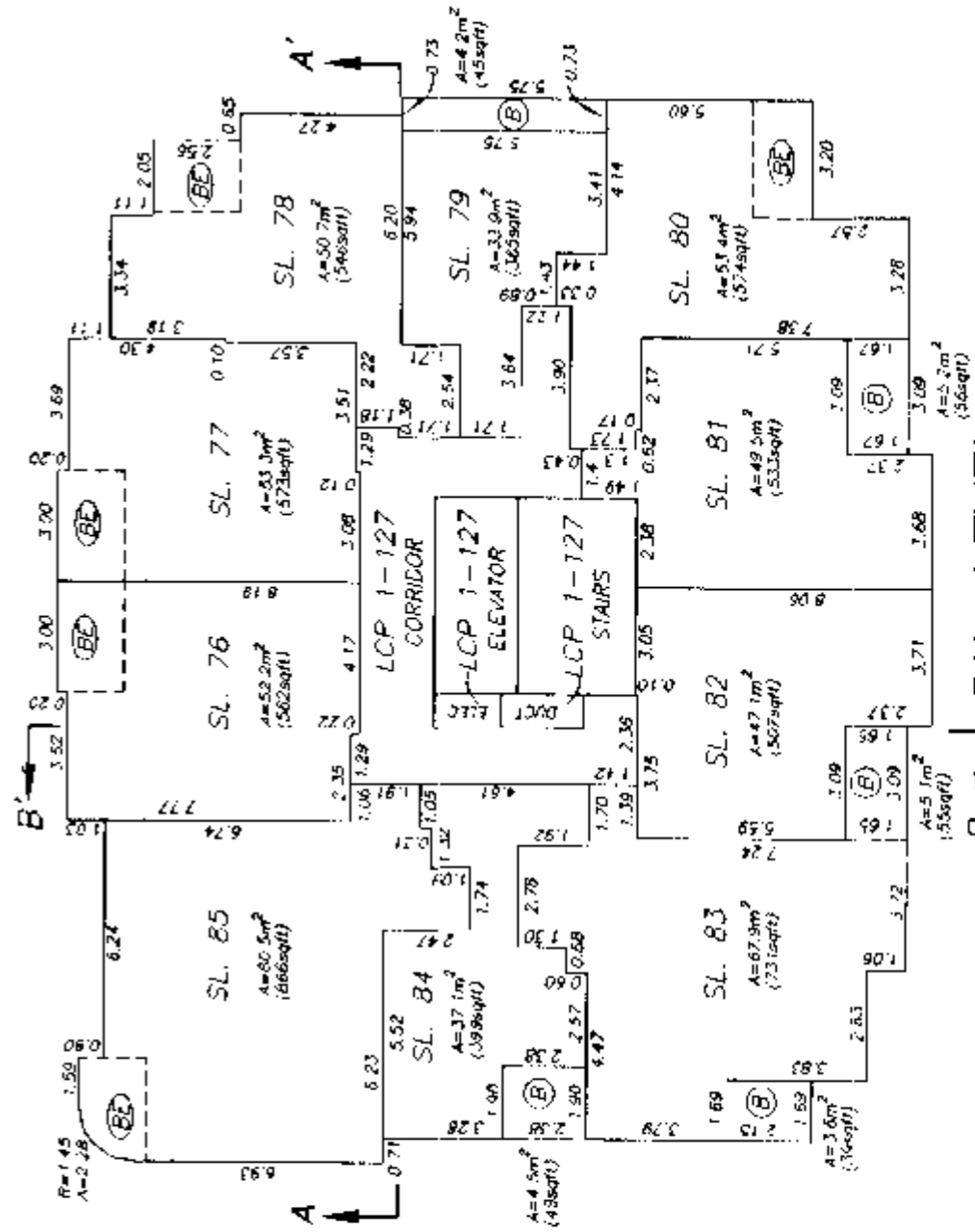

8th LEVEL RESIDENTIAL

STRATA LOT BOUNDARY DEFINITION: CENTRELINE OF WALLS FOR ALL RESIDENTIAL STRATA LOTS

DATED THIS 10th DAY OF AUGUST, 1998

FILE: 12608\8-14TH

FLOOR PLANS

STRATA PLAN LMS 3463

SCALE 1 : 200



ALL DISTANCES ARE IN METRES

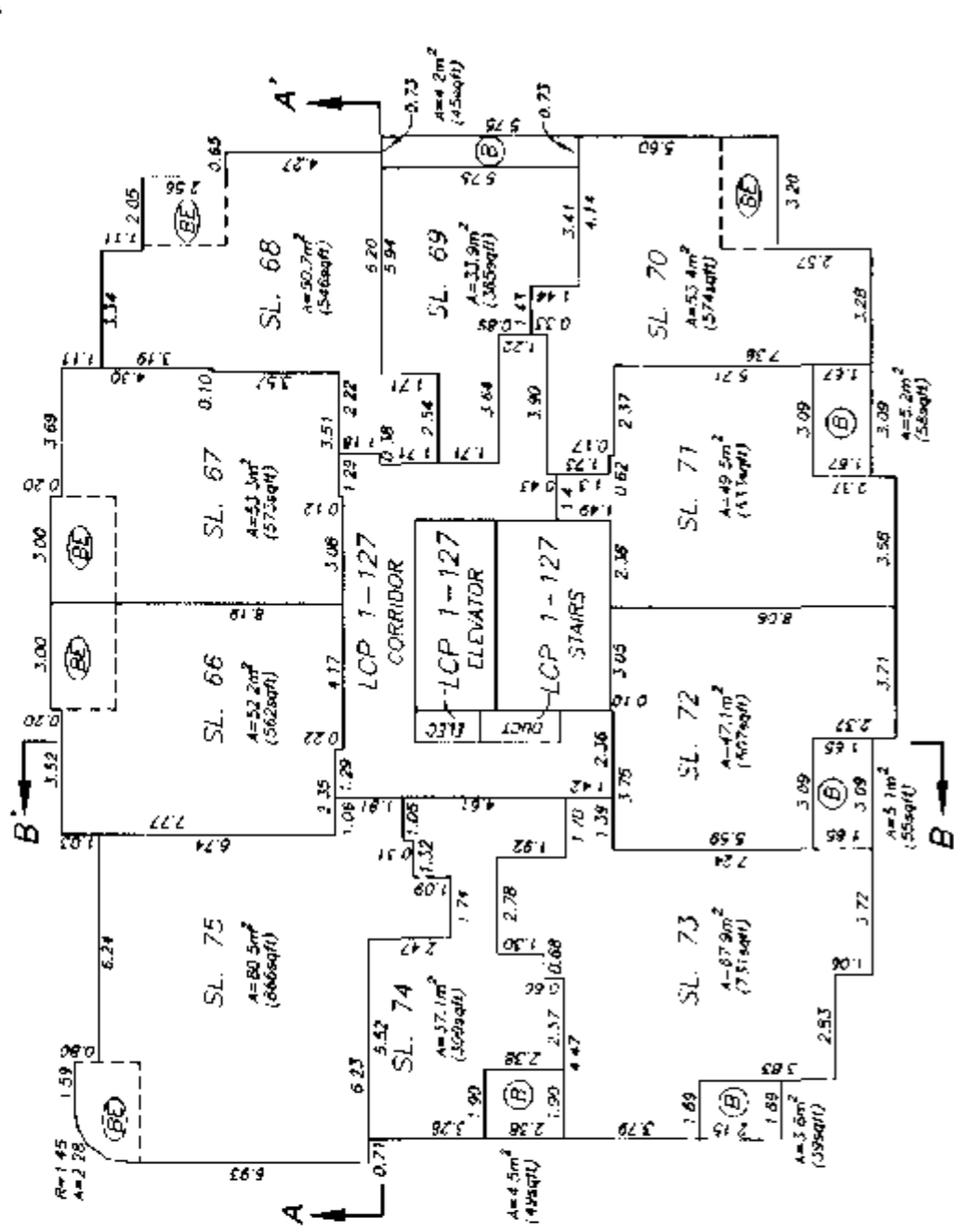

9th LEVEL
RESIDENTIAL

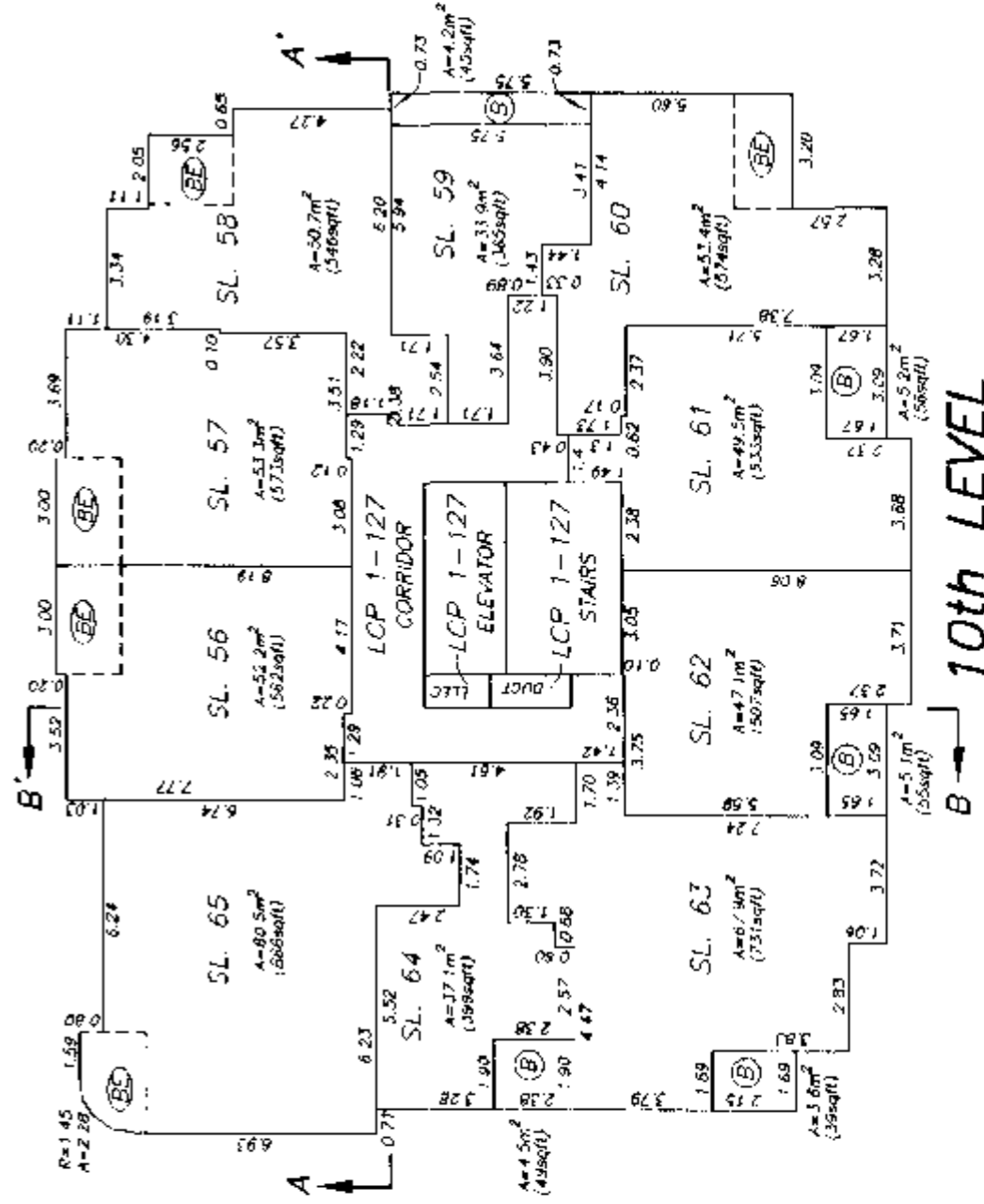

10th LEVEL
RESIDENTIAL

STRATA LOT BOUNDARY DEFINITION:
CENTRELINE OF WALLS FOR ALL RESIDENTIAL STRATA LOTS

DATED THIS TENTH DAY OF
AUGUST, 1998

B.C.L.S.
FIGURE 12608\6-14TH

FLOOR PLANS

STRATA PLAN LMS 3463

SCALE 1 : 200



ALL DISTANCES ARE IN METRES

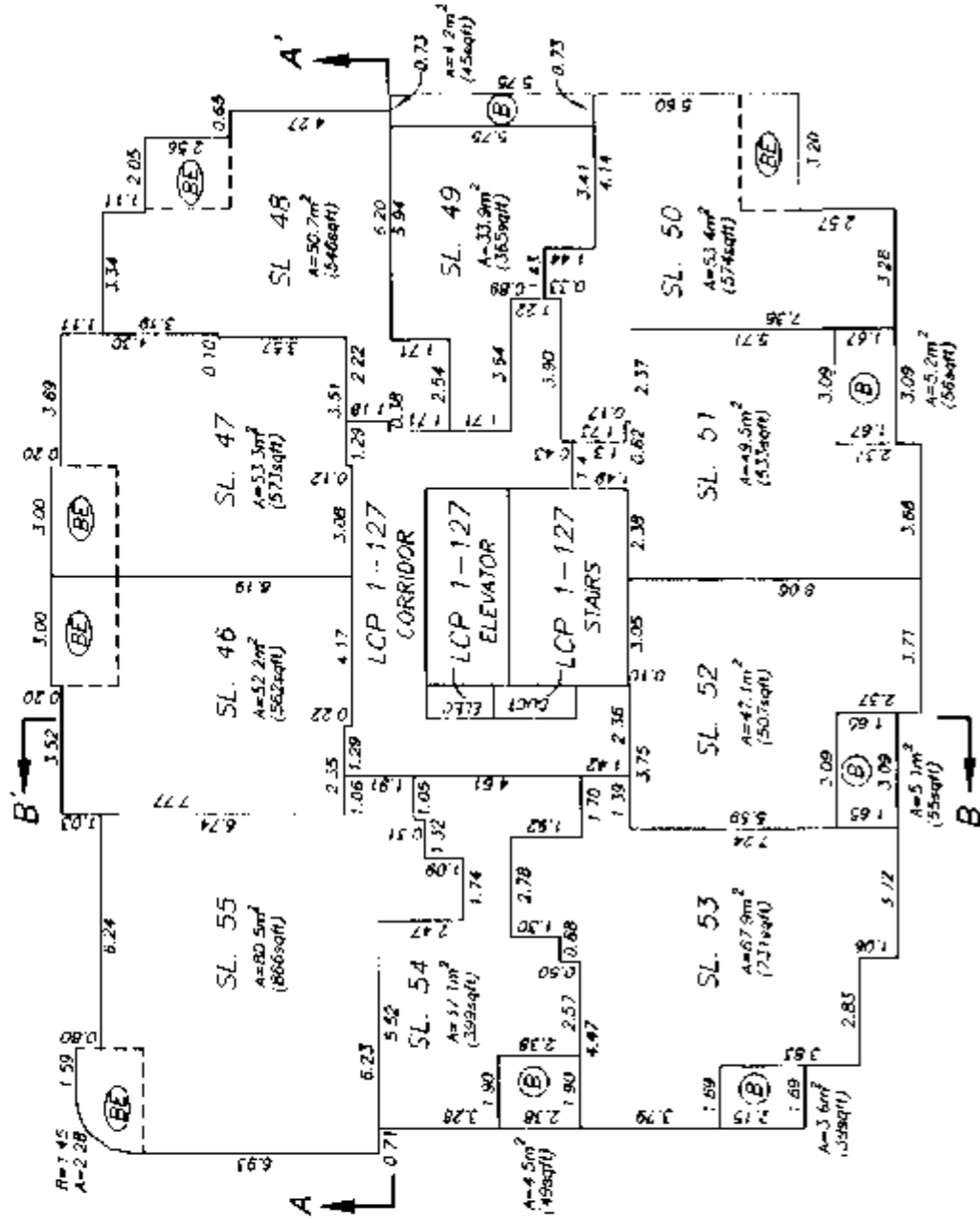

11th LEVEL
RESIDENTIAL

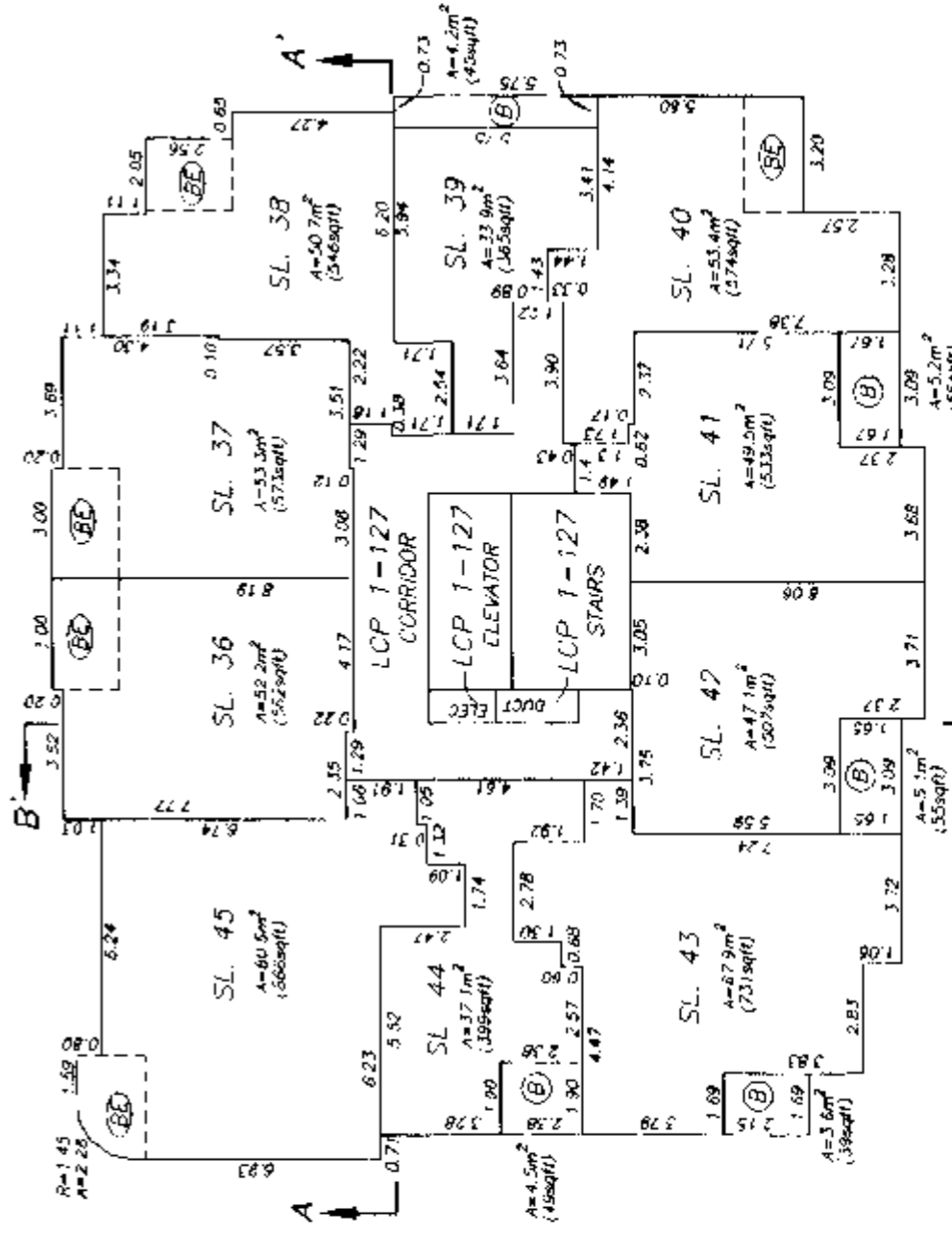

12th LEVEL
RESIDENTIAL

STRATA LOT BOUNDARY DEFINITION:
CENTRELINE OF WALLS FOR ALL RESIDENTIAL STRATA LOTS

DATED THIS 10th DAY OF
AUGUST, 1998

B.C.L.S.
17618/6-14TH

FLOOR PLANS

STRATA PLAN LMS 3463

SCALE 1 : 200



ALL DISTANCES ARE IN METRES

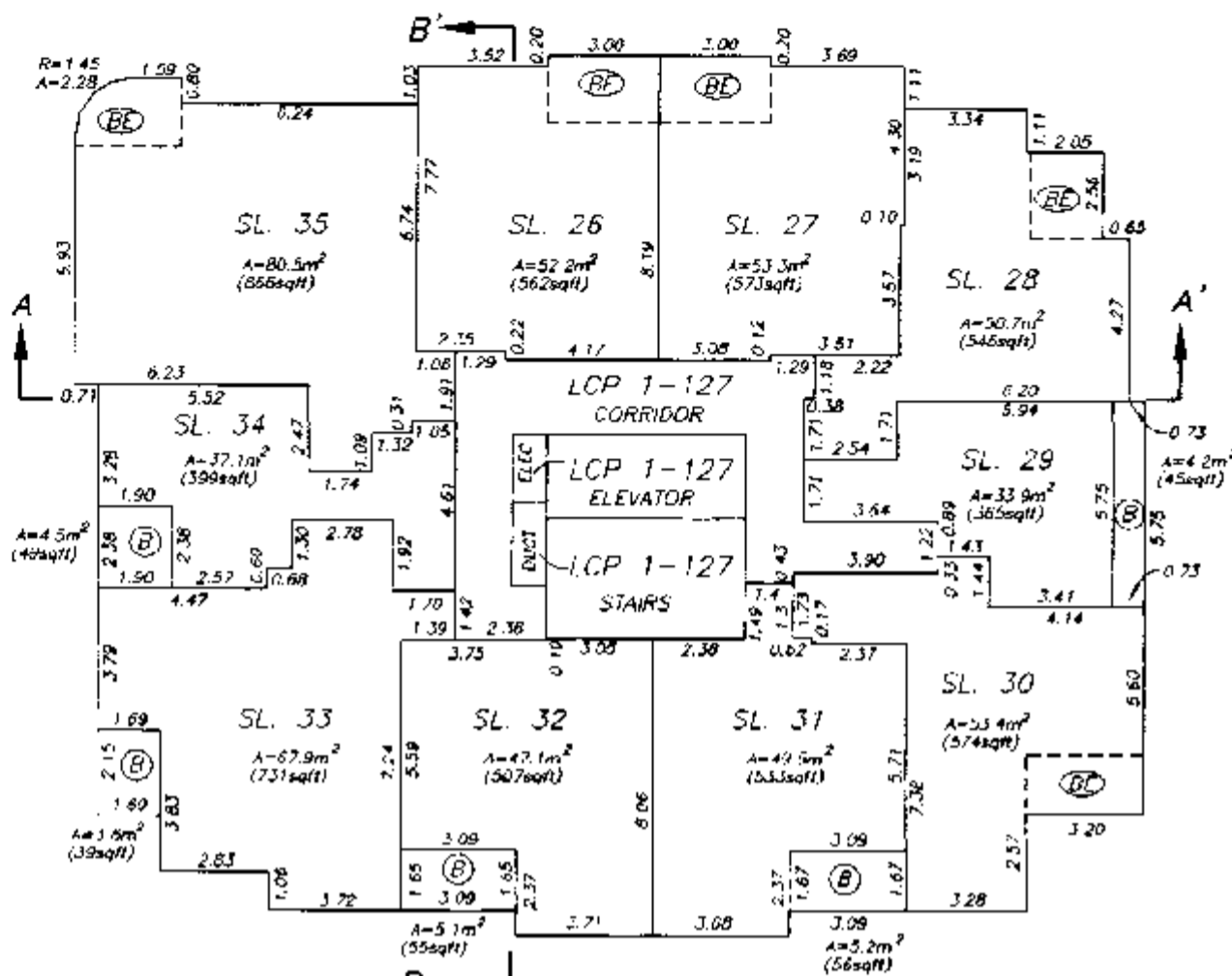

14th LEVEL

RESIDENTIAL

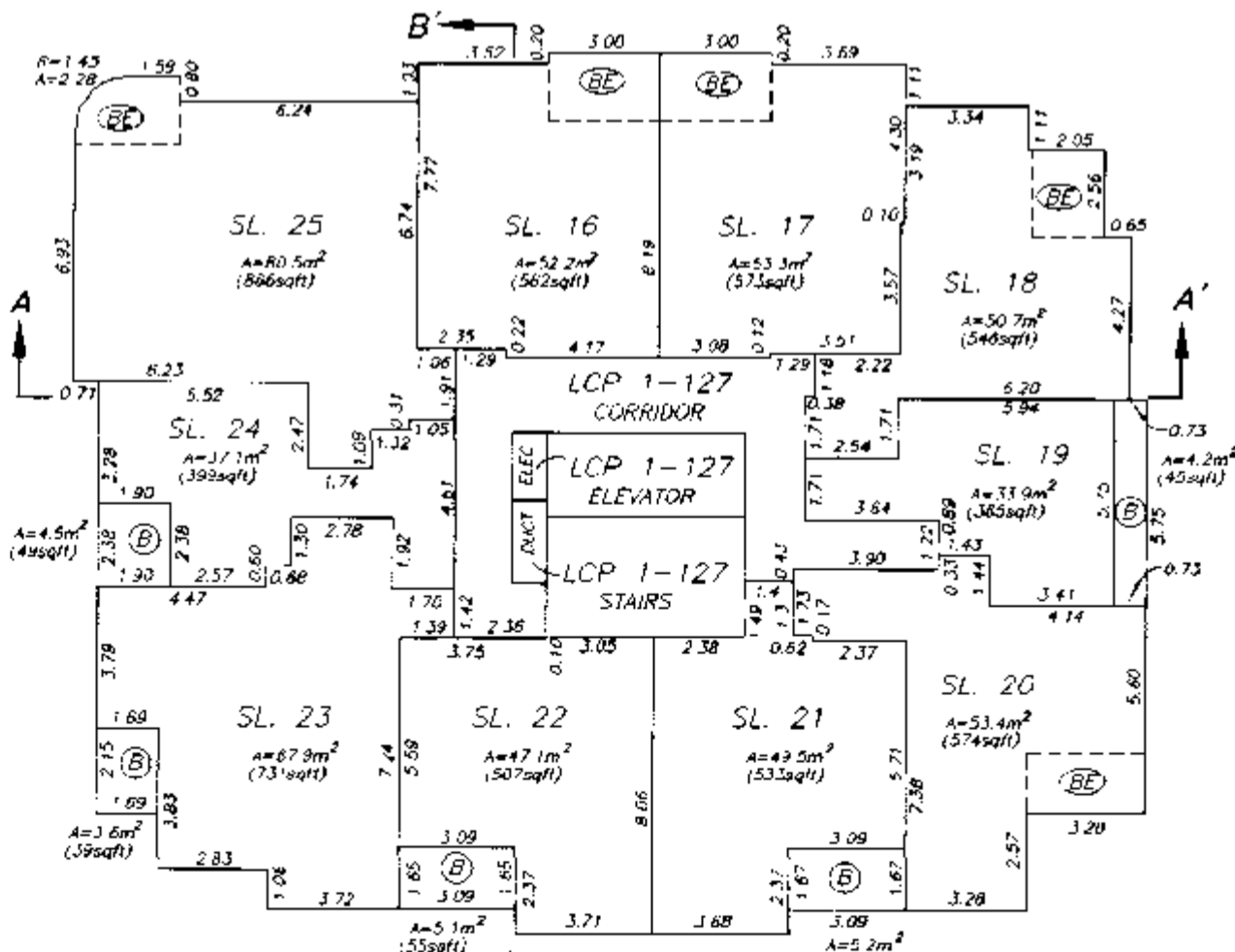

15th LEVEL

RESIDENTIAL

STRATA LOT BOUNDARY DEFINITION:
CENTRELINE OF WALLS FOR ALL RESIDENTIAL STRATA LOTS

DATED THIS 10th DAY OF
AUGUST, 1998

B.C.L.S.
FILE # 2608\6-14TH

FLOOR PLANS
RESIDENTIAL

STRATA PLAN LMS 3463

SCALE 1 : 200



ALL DISTANCES ARE IN METRES

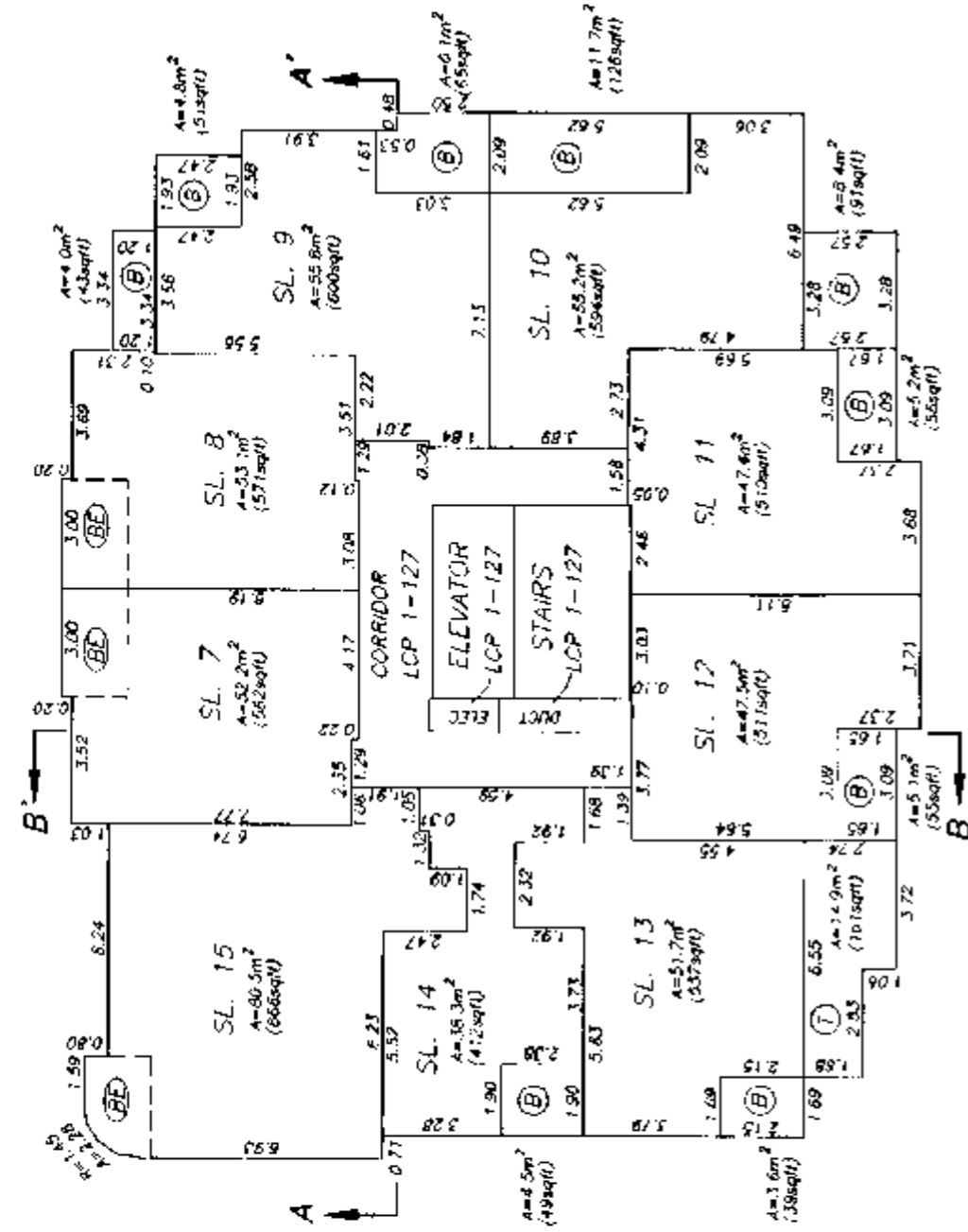

16th LEVEL
RESIDENTIAL

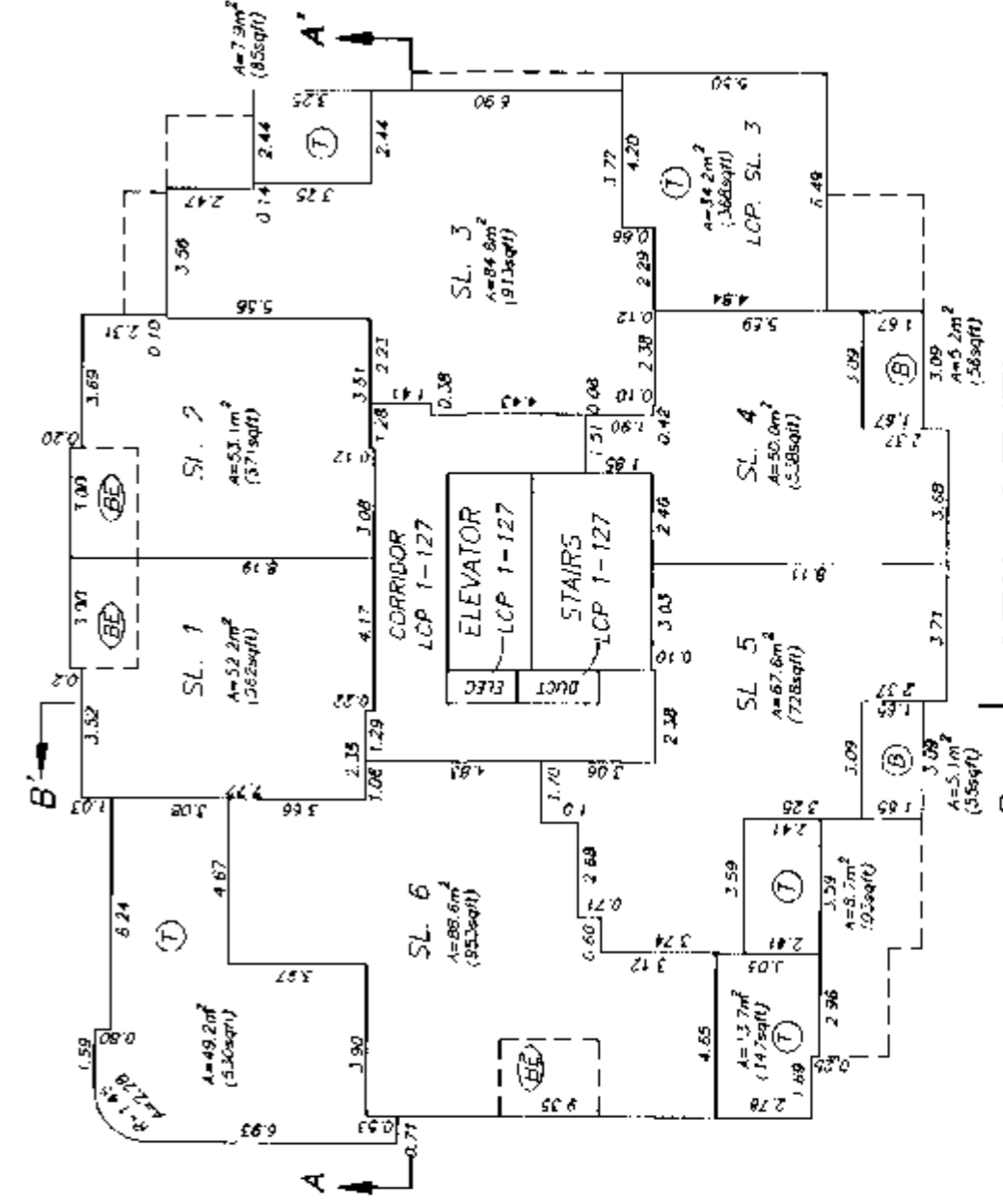

STRATA LOT BOUNDARY DEFINITION:
CENTRELINE OF WALLS FOR ALL RESIDENTIAL STRATA LOTS

DATED THIS 10th DAY OF
AUGUST, 1998
B.C.L.S.
FIR 16/08/15TH

FLOOR PLANS
RESIDENTIAL

STRATA PLAN LMS 3463

SCALE 1 : 200

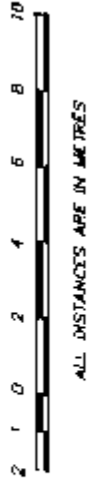

ALL DISTANCES ARE IN METRES

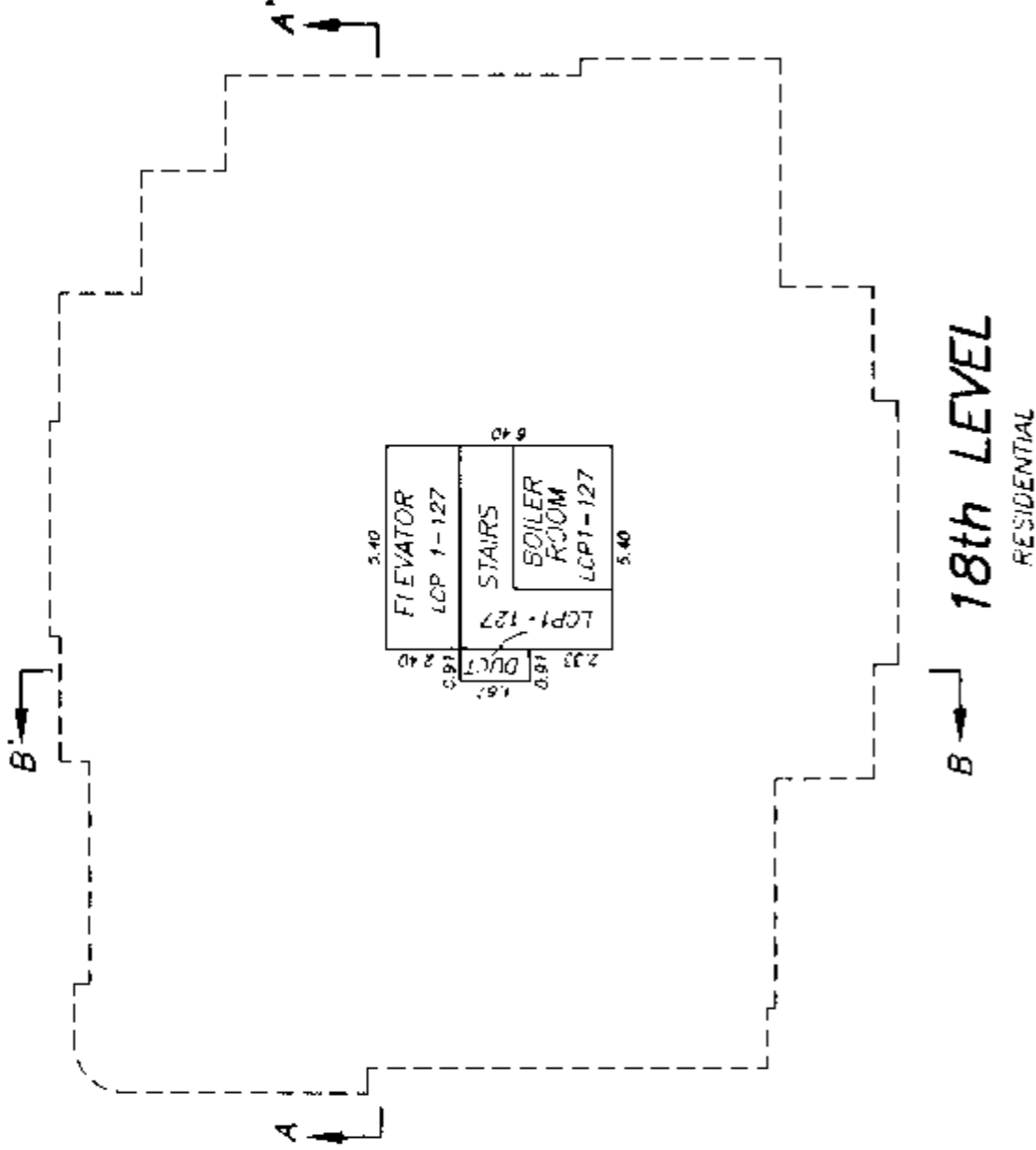

18th LEVEL
RESIDENTIAL

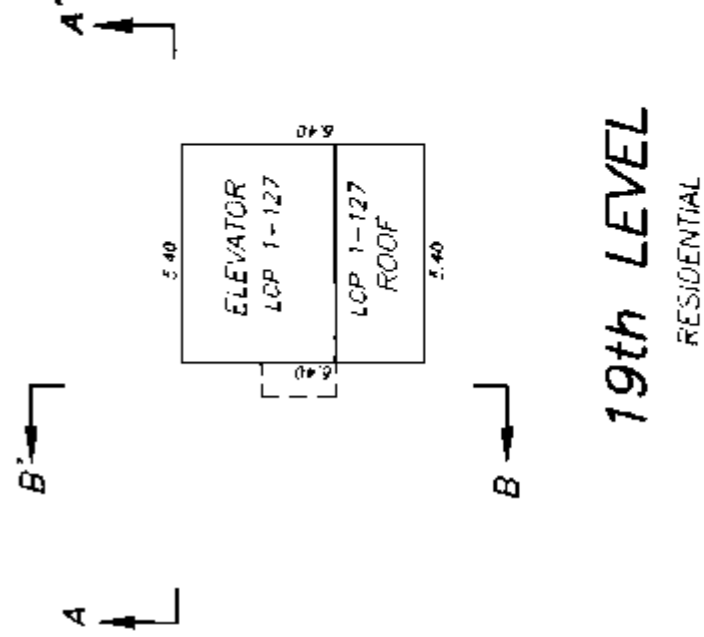

19th LEVEL
RESIDENTIAL

DATED THIS 10th DAY OF
AUGUST, 1998
B.C.L.S.
FILE: 12608/15TH



FLOOR PLANS

STRATA PLAN LMS3463

SCALE 1 : 200



ALL DISTANCES ARE IN METRES

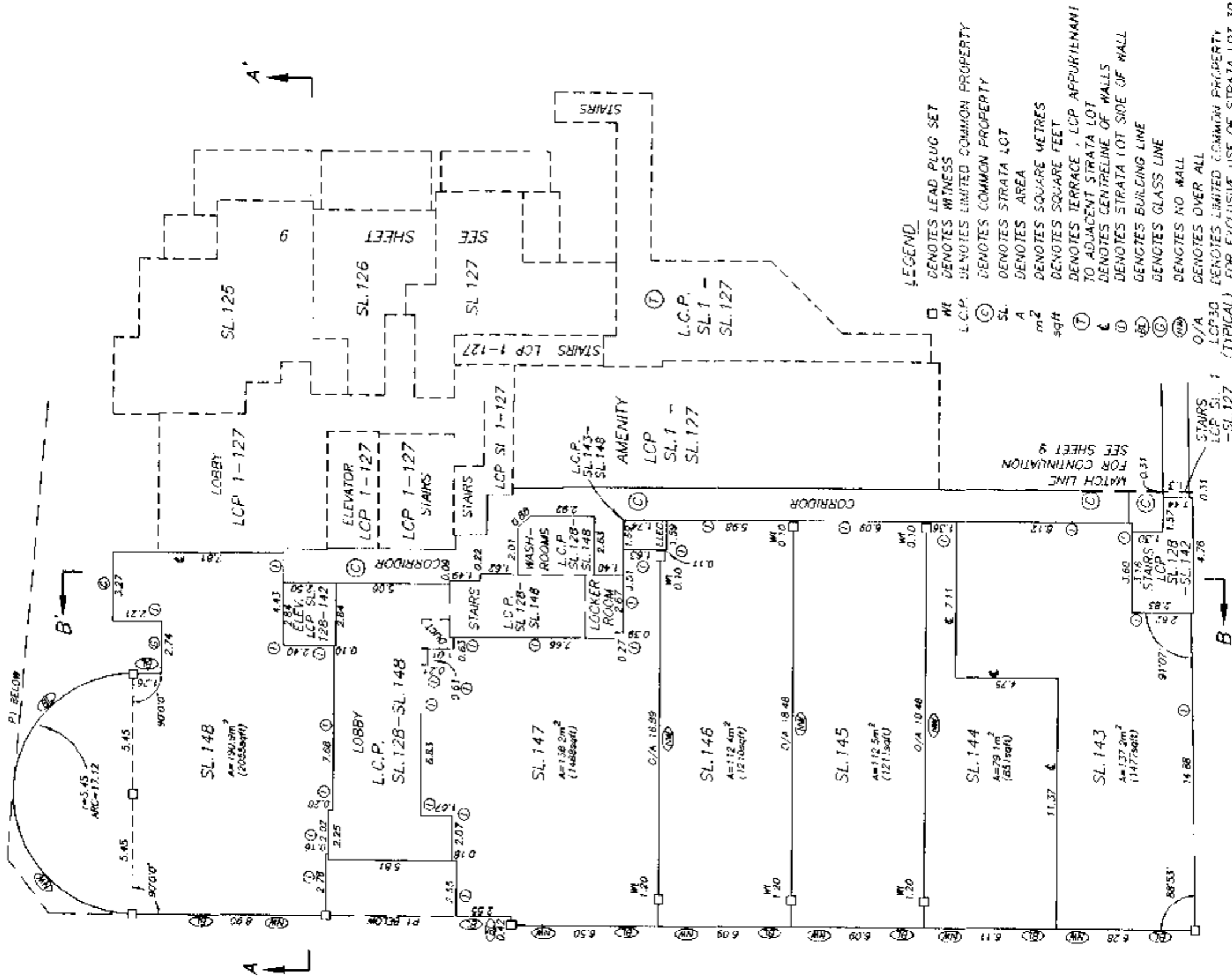

- LEGEND**
- DENOTES LEAD PLUG SET
 - ⊠ DENOTES WITNESS
 - ⊞ DENOTES LIMITED COMMON PROPERTY
 - ⊞ DENOTES COMMON PROPERTY
 - ⊞ DENOTES STRATA LOT
 - ⊞ DENOTES AREA
 - m² DENOTES SQUARE METRES
 - sqft DENOTES SQUARE FEET
 - ⑦ DENOTES TERRACE, LCP APPURTENANT TO ADJACENT STRATA LOT
 - ⊞ DENOTES CENTRELINE OF WALLS
 - ⊞ DENOTES STRATA LOT SIDE OF WALL
 - ⊞ DENOTES BUILDING LINE
 - ⊞ DENOTES GLASS LINE
 - ⊞ DENOTES NO WALL
 - O/A DENOTES OVER ALL
 - LCP30 DENOTES LIMITED COMMON PROPERTY (TYPICAL) FOR EXCLUSIVE USE OF STRATA LOT 30

1st LEVEL COMMERCIAL

STRATA LOT BOUNDARY DEFINITION:
SEE LEGEND FOR INDIVIDUAL BOUNDARY DESIGNATION

DATED THIS 24th DAY OF
AUGUST, 1998
[Signature]
B.C.L.S.
FILE: \2608\11ST

FLOOR PLANS

STRATA PLAN LMS3463

SCALE 1 : 200



ALL DISTANCES ARE IN METRES



FOR RESIDENTIAL STRATA LOTS
SEE SHEET 9

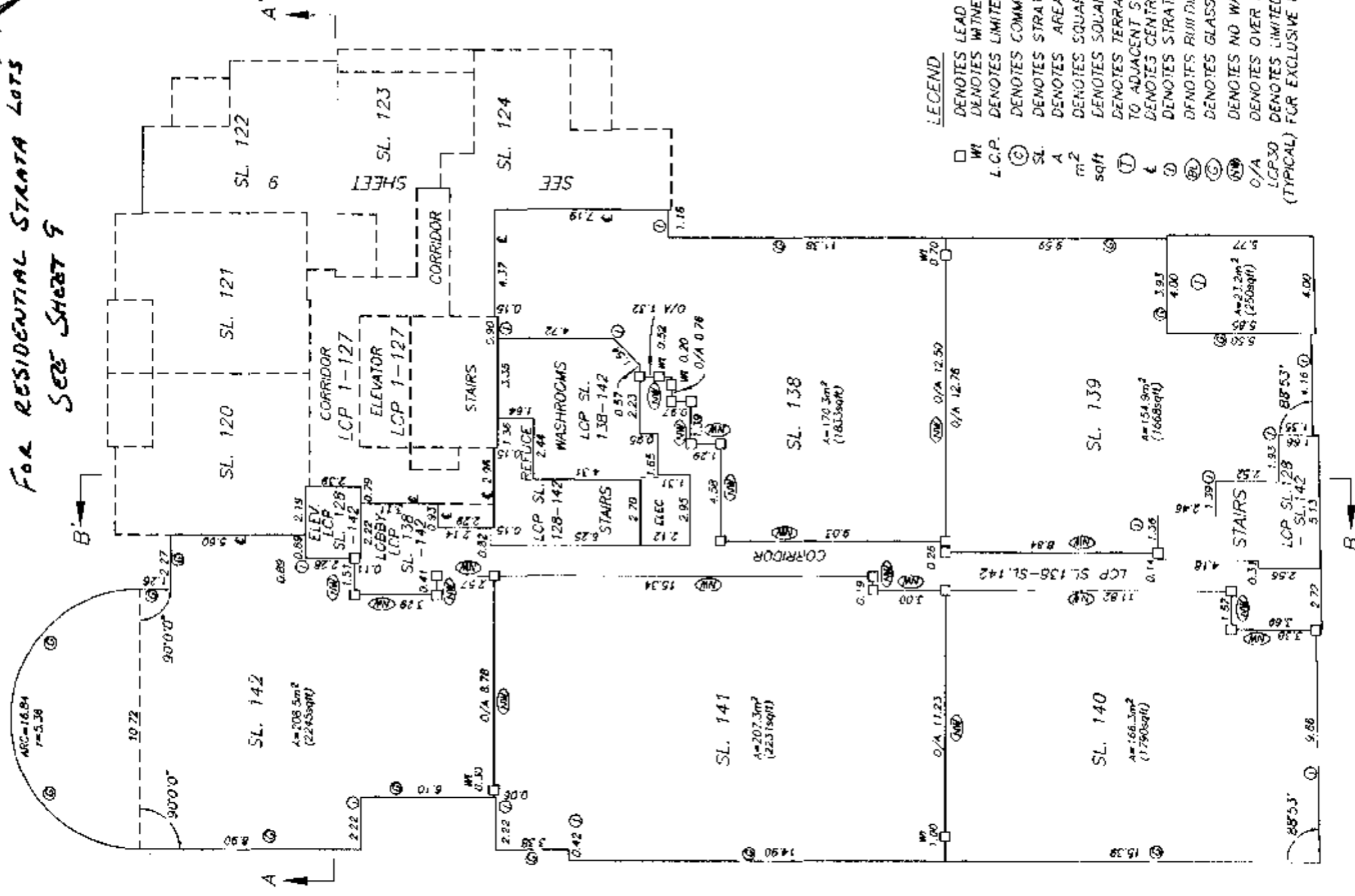

LEGEND

- DENOTES LEAD PLUG SET
- WT DENOTES WITNESS
- L.C.P. DENOTES LIMITED COMMON PROPERTY
- ⊙ DENOTES COMMON PROPERTY
- SL DENOTES STRATA LOT
- A DENOTES AREA
- m² DENOTES SQUARE METRES
- sqft DENOTES SQUARE FEET
- ⊕ DENOTES TERRACE, LCP APPURTENANT TO ADJACENT STRATA LOT
- ⊖ DENOTES CENTRELINE OF WALLS
- ⊗ DENOTES STRATA LOT SIDE OF WALL
- ⊘ DENOTES BUILDING LINE
- ⊙ DENOTES GLASS LINE
- ⊚ DENOTES NO WALL
- /A DENOTES OVER ALL
- LCP30 DENOTES LIMITED COMMON PROPERTY (TYPICAL) FOR EXCLUSIVE USE OF STRATA LOT 30

2nd LEVEL COMMERCIAL

STRATA LOT BOUNDARY DEFINITION:
SEE LEGEND FOR INDIVIDUAL BOUNDARY DESIGNATION

DATED THIS 21st DAY OF
AUGUST, 1998

[Signature] B.C.L.S.

FILE: \2E08\C2ND

FLOOR PLANS

STRATA PLAN LMS3463

SCALE 1 : 200



ALL DISTANCES ARE IN METRES



FOR RESIDENTIAL STRATA LOTS
SEE SHEET 10

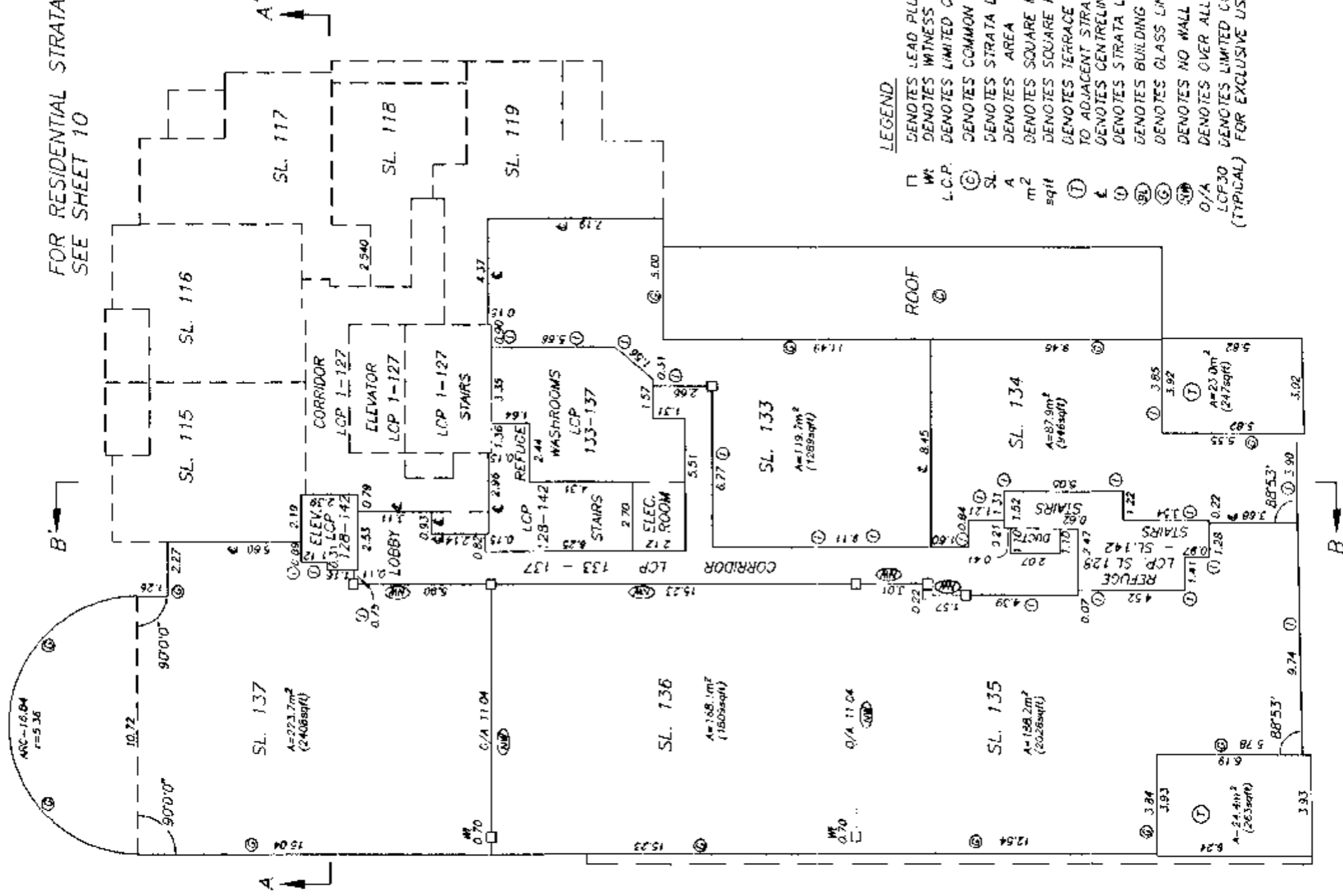

LEGEND

- Ⓜ DENOTES LEAD PLUG SET
- Ⓜ DENOTES WITNESS
- L.C.P. DENOTES LIMITED COMMON PROPERTY
- Ⓢ DENOTES COMMON PROPERTY
- SL DENOTES STRATA LOT
- A DENOTES AREA
- m² DENOTES SQUARE METRES
- sqft DENOTES SQUARE FEET
- Ⓣ DENOTES TERRACE - LCP APPURTENANT TO ADJACENT STRATA LOT
- Ⓛ DENOTES CENTRELINE OF WALLS
- Ⓛ DENOTES STRATA LOT SIDE OF WALL
- ⓈL DENOTES BUILDING LINE
- Ⓢ DENOTES GLASS LINE
- Ⓢ DENOTES NO WALL
- Ⓢ DENOTES OVER ALL
- O/A DENOTES LIMITED COMMON PROPERTY (TYPICAL) FOR EXCLUSIVE USE OF STRATA LOT 30

3rd LEVEL COMMERCIAL

STRATA LOT BOUNDARY DEFINITION:
SEE LEGEND FOR INDIVIDUAL BOUNDARY DESIGNATION

DATED THIS 21st DAY OF
AUGUST, 1998

FILE: 12608\C3RD

FLOOR PLANS

STRATA PLAN LMS3463

SCALE 1 : 200



ALL DISTANCES ARE IN METRES



FOR RESIDENTIAL STRATA LOTS
SEE SHEET 10

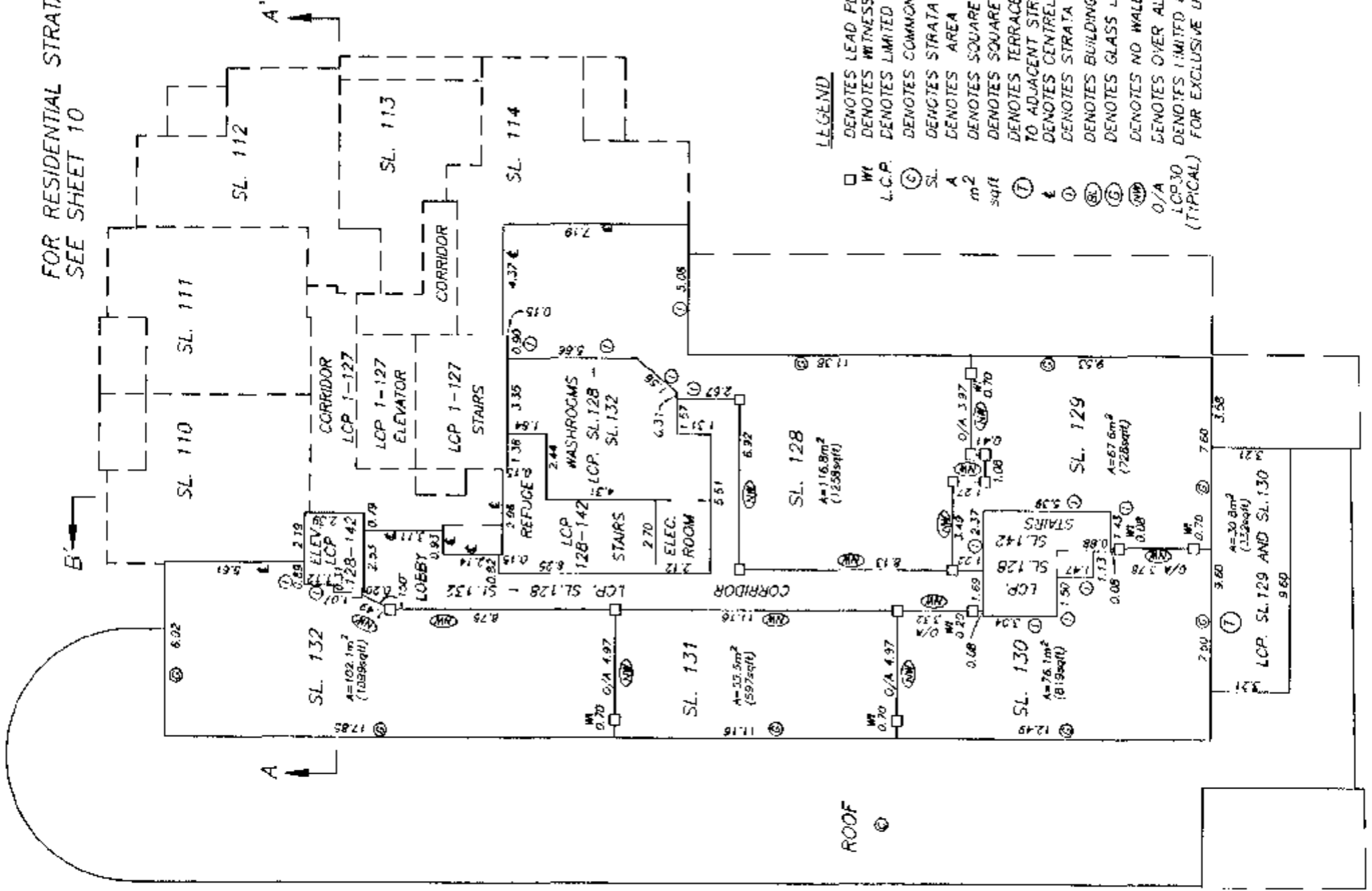

- LEGEND**
- DENOTES LEAD PLUG SET
 - DENOTES WITNESS
 - L.C.P. DENOTES LIMITED COMMON PROPERTY
 - DENOTES COMMON PROPERTY
 - DENOTES STRATA LOT
 - DENOTES AREA
 - m² DENOTES SQUARE METRES
 - sqft DENOTES SQUARE FEET
 - DENOTES TERRACE, LCP APPURTENANT TO ADJACENT STRATA LOT
 - DENOTES CENTRELINE OF WALLS
 - DENOTES STRATA LOT SIDE OF WALL
 - DENOTES BUILDING LINE
 - DENOTES GLASS LINE
 - DENOTES NO WALL
 - DENOTES OVER ALL
 - O/A DENOTES LIMITED COMMON PROPERTY (TYPICAL) FOR EXCLUSIVE USE OF STRATA LOT 30

4th LEVEL COMMERCIAL

STRATA LOT BOUNDARY DEFINITION:
SEE LEGEND FOR INDIVIDUAL BOUNDARY DESIGNATION

DATED THIS 21st DAY OF
AUGUST, 1998
[Signature] B.C.L.S.
FILE: \2608\C4TH

SECTION PLANS

STRATA PLAN LMS3463

SCALE 1 : 200

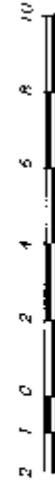

ALL DISTANCES ARE IN METRES

SECTION A - A'

(LEVEL 13th IS NOT USED)

	SL. 6	LCP 1-127 CORRIDOR	SL. 3	LEVEL 17
	SL. 14	LCP 1-127 CORRIDOR	SL. 9 (B)	LEVEL 16
	SL. 24	LCP 1-127 CORRIDOR	SL. 18	LEVEL 15
	SL. 34	LCP 1-127 CORRIDOR	SL. 28	LEVEL 14
	SL. 44	LCP 1-127 CORRIDOR	SL. 38	LEVEL 12
	SL. 54	LCP 1-127 CORRIDOR	SL. 48	LEVEL 11
	SL. 64	LCP 1-127 CORRIDOR	SL. 58	LEVEL 10
	SL. 74	LCP 1-127 CORRIDOR	SL. 68	LEVEL 9
	SL. 84	LCP 1-127 CORRIDOR	SL. 78	LEVEL 8
	SL. 94	LCP 1-127 CORRIDOR	SL. 88	LEVEL 7
	SL. 103	LCP 1-127 CORRIDOR	SL. 98	LEVEL 6
LEVEL 4	SL. 132	LCP 1-127 CORRIDOR	SL. 107	LEVEL 5
LEVEL 3	SL. 137	LCP 1-127 CORRIDOR	SL. 112	LEVEL 4
LEVEL 2	SL. 142	LCP 1-127 CORRIDOR	SL. 117	LEVEL 3
LEVEL 1	SL. 148	LCP 1-127 CORRIDOR	SL. 122	LEVEL 2
LEVEL P1	VISITOR AND COMMERCIAL PARKING	LOBBY LCP 1-127	SL. 125	LEVEL 1
LEVEL P2	VISITOR AND COMMERCIAL PARKING	LOBBY LCP 1-127	RESIDENTIAL PARKING LCP 1-127	LEVEL P1
LEVEL P3	RESIDENTIAL PARKING LCP 1-127	LOBBY LCP 1-127	RESIDENTIAL PARKING LCP 1-127	LEVEL P2
LEVEL P4	RESIDENTIAL PARKING LCP 1-127	LOBBY LCP 1-127	RESIDENTIAL PARKING LCP 1-127	LEVEL P3
		LOBBY LCP 1-127	RESIDENTIAL PARKING LCP 1-127	LEVEL P4

DATED THIS 10th DAY OF AUGUST, 1998
 B.C.L.S.
 FILE: 12508\SECTION

SHEET 23 OF 25 SHEETS

STRATA PLAN LMS3463

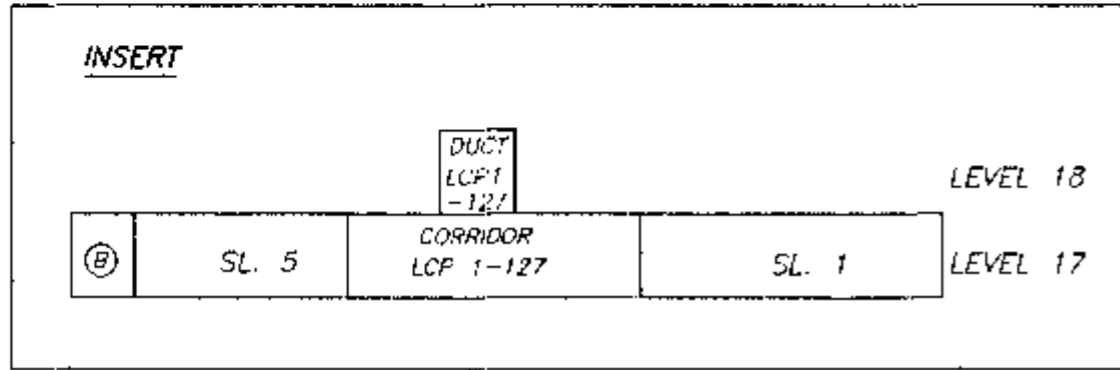

SECTION B - B'
(LEVEL 13th IS NOT USED)

	FOR CONTINUATION	SEE	INSERT	
ⓑ	SL 5	CORRIDOR LCP 1-127	SL. 1	LEVEL 17
ⓑ	SL 12	CORRIDOR LCP 1-127	SL. 7	LEVEL 16
ⓑ	SL 22	CORRIDOR LCP 1-127	SL. 16	LEVEL 15
ⓑ	SL 32	CORRIDOR LCP 1-127	SL. 26	LEVEL 14
ⓑ	SL 42	CORRIDOR LCP 1-127	SL. 36	LEVEL 12
ⓑ	SL 52	CORRIDOR LCP 1-127	SL. 46	LEVEL 11
ⓑ	SL 62	CORRIDOR LCP 1-127	SL. 56	LEVEL 10
ⓑ	SL 72	CORRIDOR LCP 1-127	SL. 66	LEVEL 9
ⓑ	SL 82	CORRIDOR LCP 1-127	SL. 76	LEVEL 8
ⓑ	SL 92	CORRIDOR LCP 1-127	SL. 86	LEVEL 7
ⓑ	AMENITY LCP 1-127	CORRIDOR LCP 1-127	SL. 96	LEVEL 6

DATED THIS 10th DAY OF AUGUST, 1998
D.C.L.S.
FILE: \2608\SECTION

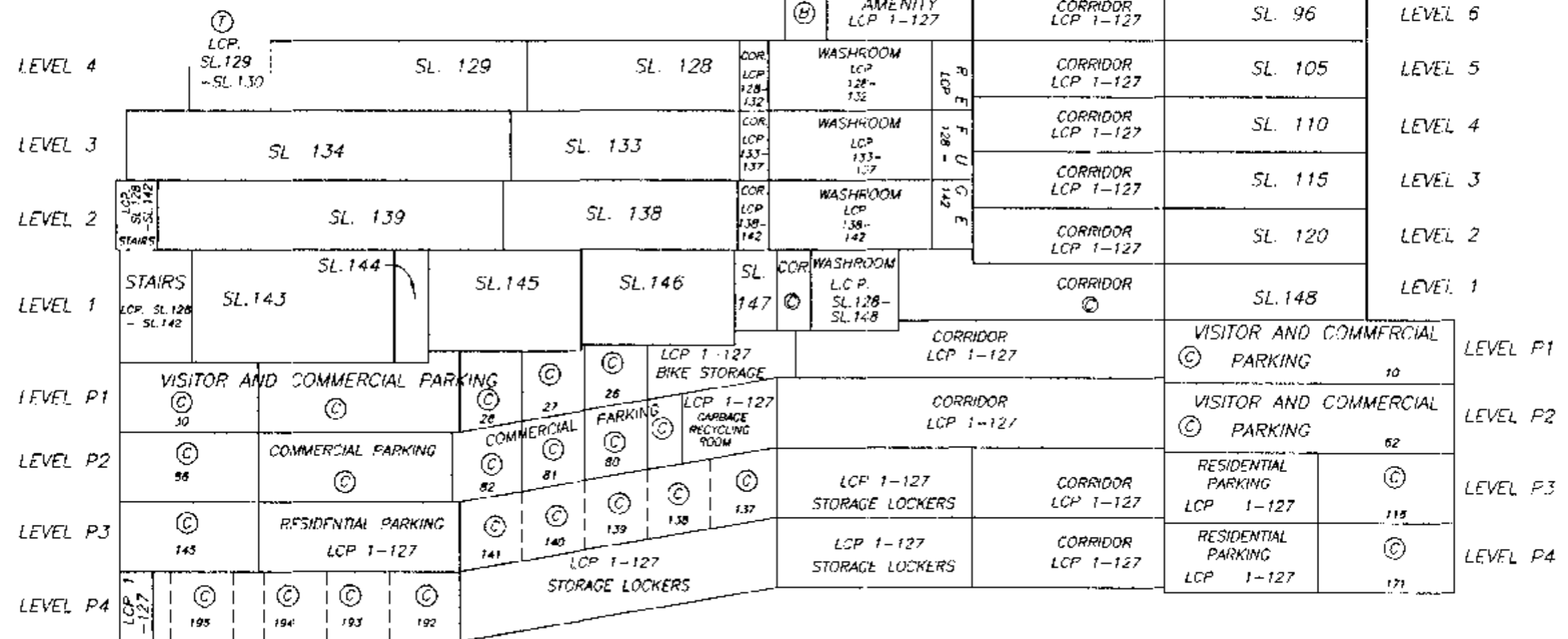
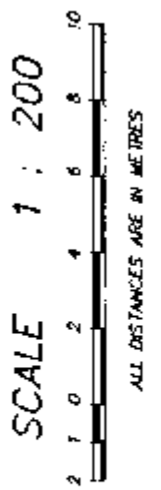

SECTION PLANS

STRATA PLAN LMS 3463

RECORD OF BY-LAWS AND ORDERS, ETC.

FILING		DOCUMENT	
NUMBER	DATE	DATE	NATURE AND PARTICULARS
			Hylaw Sheet Closed
			Search ALIOS2 of BC OnLine for Current Information. BC Reg. 76/95

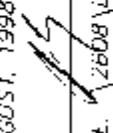
DATED THIS 10th DAY OF
 AUGUST, 1998

 FILE. 2608 \LOT1-S1 B.C.L.S.