

**STRATA PLAN OF LOT 1  
BLOCK 372 DISTRICT LOT 526 GROUP 1  
NEW WESTMINSTER DISTRICT PLAN BCP24169**

**STRATA PLAN BCS 2886**

CITY OF VANCOUVER  
B.C.G.S. 92G.025

DEPOSITED AND REGISTERED IN THE LAND  
TITLE OFFICE AT NEW WESTMINSTER B.C.  
MAY 6 2008

IAN MAC DONALD /CP  
REGISTRAR

BB 856 094 - BB 856 156

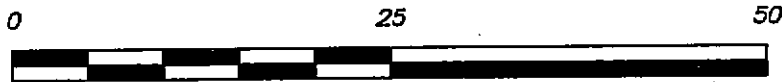

SCALE 1 : 500 DISTANCES ARE IN METRES

**INTEGRATED SURVEY AREA NO. 31 (VANCOUVER)**

THIS PLAN SHOWS GROUND LEVEL MEASURED DISTANCES.  
PRIOR TO COMPUTATION OF U.T.M. CO-ORDINATES,  
MULTIPLY BY COMBINED FACTOR 0.9995965

**CIVIC ADDRESS:**

1133 WEST 11th AVENUE  
VANCOUVER B.C.

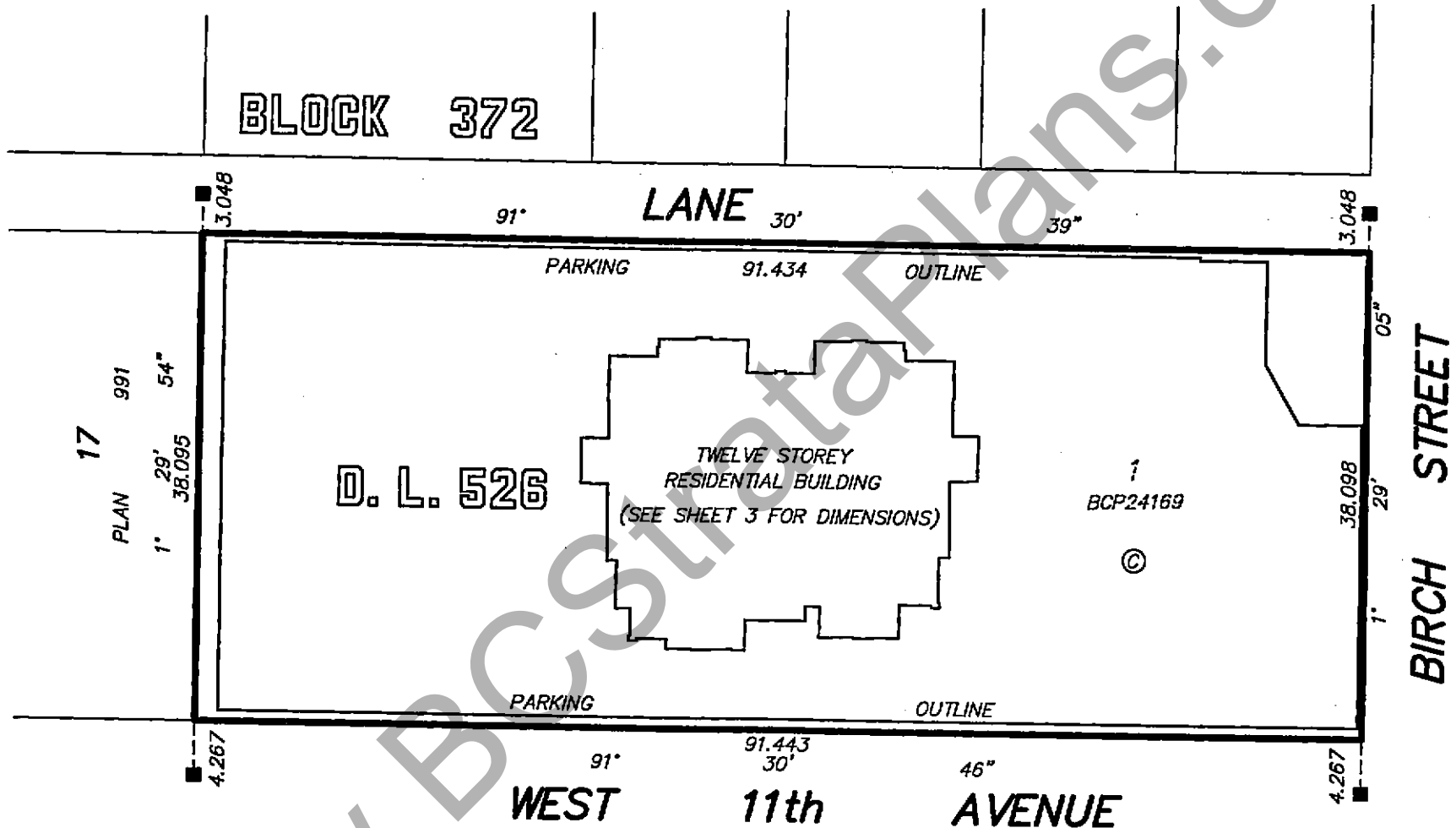
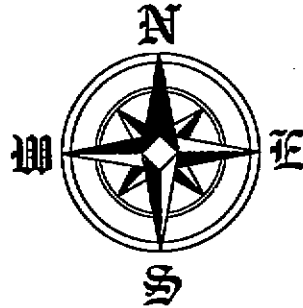

**LEGEND**

GRID BEARINGS ARE DERIVED FROM PLAN BCP24169

- DENOTES LEAD PLUG FOUND
- SL. DENOTES STRATA LOT
- m2 DENOTES SQUARE METRES
- ⊙ DENOTES COMMON PROPERTY
- Ⓧ DENOTES DUCT BEING COMMON PROPERTY
- Ⓨ DENOTES ELECTRICAL ROOM BEING COMMON PROPERTY
- Ⓩ DENOTES MECHANICAL BEING COMMON PROPERTY
- ⓐ DENOTES BALCONY BEING LIMITED COMMON PROPERTY FOR EXCLUSIVE USE OF ADJOINING STRATA LOT
- (B-61) DENOTES BALCONY BEING LIMITED COMMON PROPERTY FOR EXCLUSIVE USE OF STRATA LOT 61 (TYPICAL)
- (P-2) DENOTES PATIO BEING LIMITED COMMON PROPERTY FOR EXCLUSIVE USE OF STRATA LOT 2 (TYPICAL)

I, GARY SUNDVICK, A BRITISH COLUMBIA LAND SURVEYOR, OF LANGLEY, BRITISH COLUMBIA, CERTIFY THAT I WAS PRESENT AT AND PERSONALLY SUPERINTENDED THE SURVEY REPRESENTED BY THIS PLAN, AND THAT THE SURVEY AND PLAN ARE CORRECT. THE FIELD SURVEY WAS COMPLETED ON THE 11th DAY OF MARCH, 2008. THE PLAN WAS COMPLETED AND CHECKED, AND THE CHECKLIST FILED UNDER ECP.#78407 ON THE 14th DAY OF MARCH, 2008.

G. Sundvick B.C.L.S.

BUTLER SUNDVICK & ASSOCIATES  
PROFESSIONAL LAND SURVEYORS  
4, 19089 94th AVENUE  
SURREY, B.C. V4N 3S4  
T. 604-513-9611 F. 604-513-2202  
FILE : 3328/STRATA  
DWG : 3328-ST

THIS PLAN LIES WITHIN THE GREATER VANCOUVER REGIONAL DISTRICT

ORIGINAL

FILED VABCS2886 RCVD:2008-05-06 ROST:2011-10-31-11.07.08.870

STRATA PLAN BCS 2886

STRATA PROPERTY ACT

OWNER:

POLYGON BIRCH TOWER LTD.  
(INC. No. 719489)

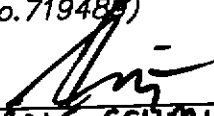
  
Name KALF SCHMIDTKE  
Authorized Signatory

  
Name ROBERT BRUNO  
Authorized Signatory

  
WITNESS AS TO BOTH SIGNATURES  
Name MARCELA CORZO

900-1333 WEST BROADWAY ST.  
ADDRESS

VANCOUVER, BC, V6H 4C2

DEVELOPMENT COORDINATOR  
OCCUPATION OF WITNESS

MORTGAGEE:

HSBC BANK CANADA

  
Name DALE TELFER  
Authorized Signatory

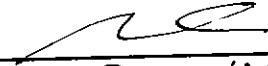
  
Name PAUL VASSALLO  
Authorized Signatory

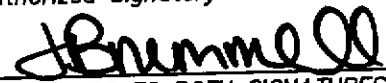
  
WITNESS AS TO BOTH SIGNATURES  
Name JESSICA BRUMMELL

200, 885 West Georgia St  
ADDRESS  
Vancouver, BC V6C 3G1

Commercial Financial Services Officer  
OCCUPATION OF WITNESS

I, GARY SUNDVICK, A BRITISH COLUMBIA  
LAND SURVEYOR CERTIFY THAT THE BUILDING  
SHOWN ON THIS STRATA PLAN IS WITHIN  
THE EXTERNAL BOUNDARIES OF THE LAND THAT  
IS THE SUBJECT OF THE STRATA PLAN.  
DATE: MARCH 11, 2008

  
B.C.L.S.

I, GARY SUNDVICK, A BRITISH COLUMBIA LAND  
SURVEYOR CERTIFY THAT THE BUILDING INCLUDED  
IN THIS STRATA PLAN HAS NOT, AS OF  
MARCH 11, 2008 BEEN PREVIOUSLY OCCUPIED.

  
B.C.L.S.

www.BCStrataPlans.com

BUILDING LOCATION

STRATA PLAN BCS 2886

0 5 10 15 20  
SCALE 1:300 DISTANCES ARE IN METRES



BIRCH STREET

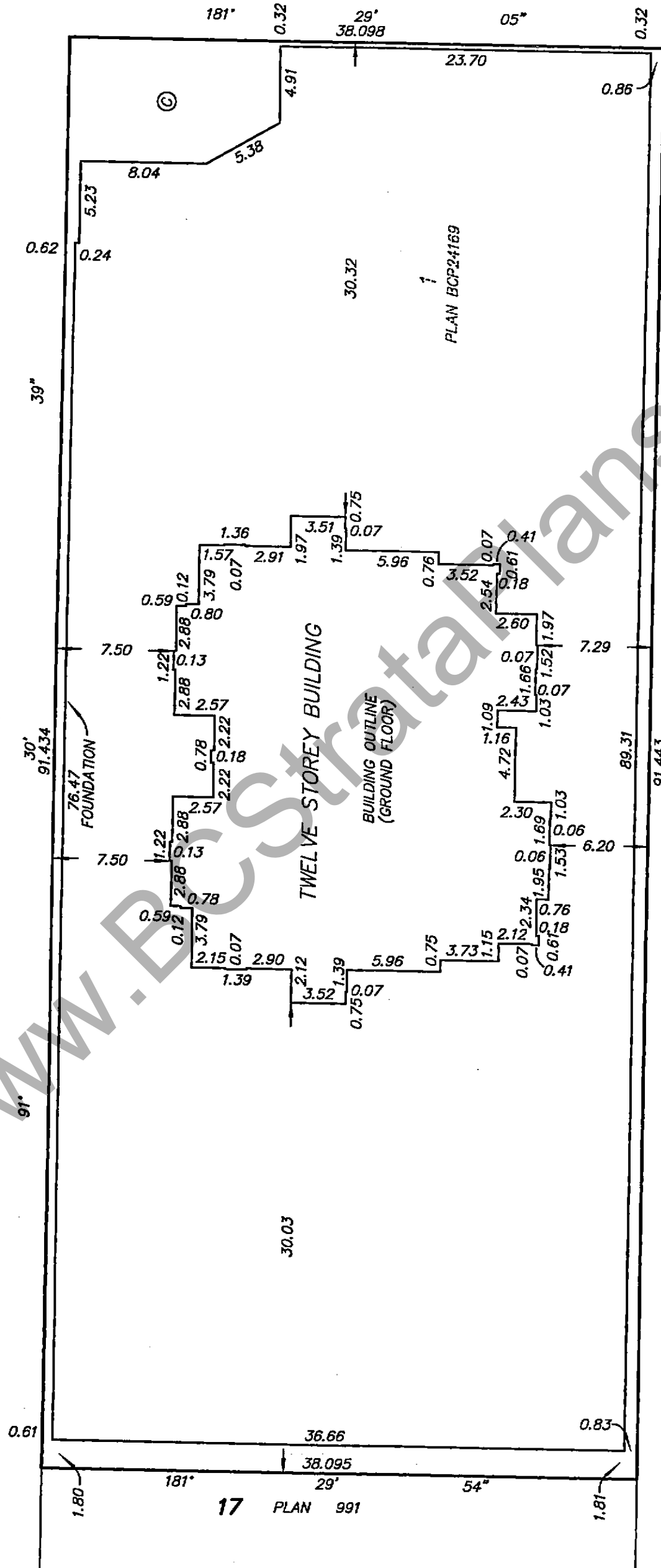

LANE

WEST 11th AVENUE

17 PLAN 991

MARCH 11, 2008  
DWG: 3328-ST

ORIGINAL

PARKING LEVEL P1

STRATA PLAN BCS 2886

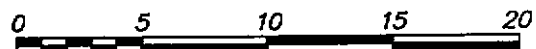

SCALE 1:300 DISTANCES ARE IN METRES

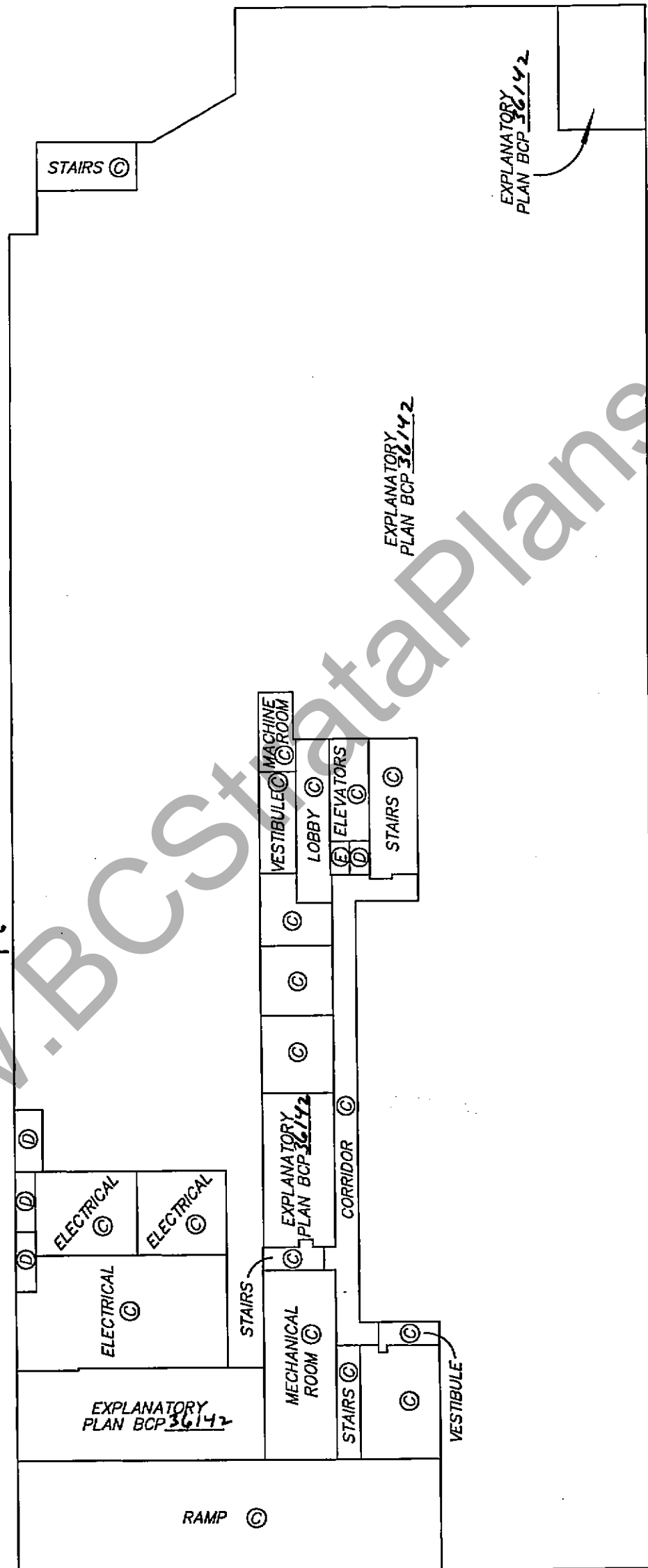

www.BCSstrataPlans.com

APRIL 23, 2008  
DWG: 3328-ST

ORIGINAL

FLOOR PLANS

STRATA PLAN BCS 2886



SCALE 1:200 DISTANCES ARE IN METRES

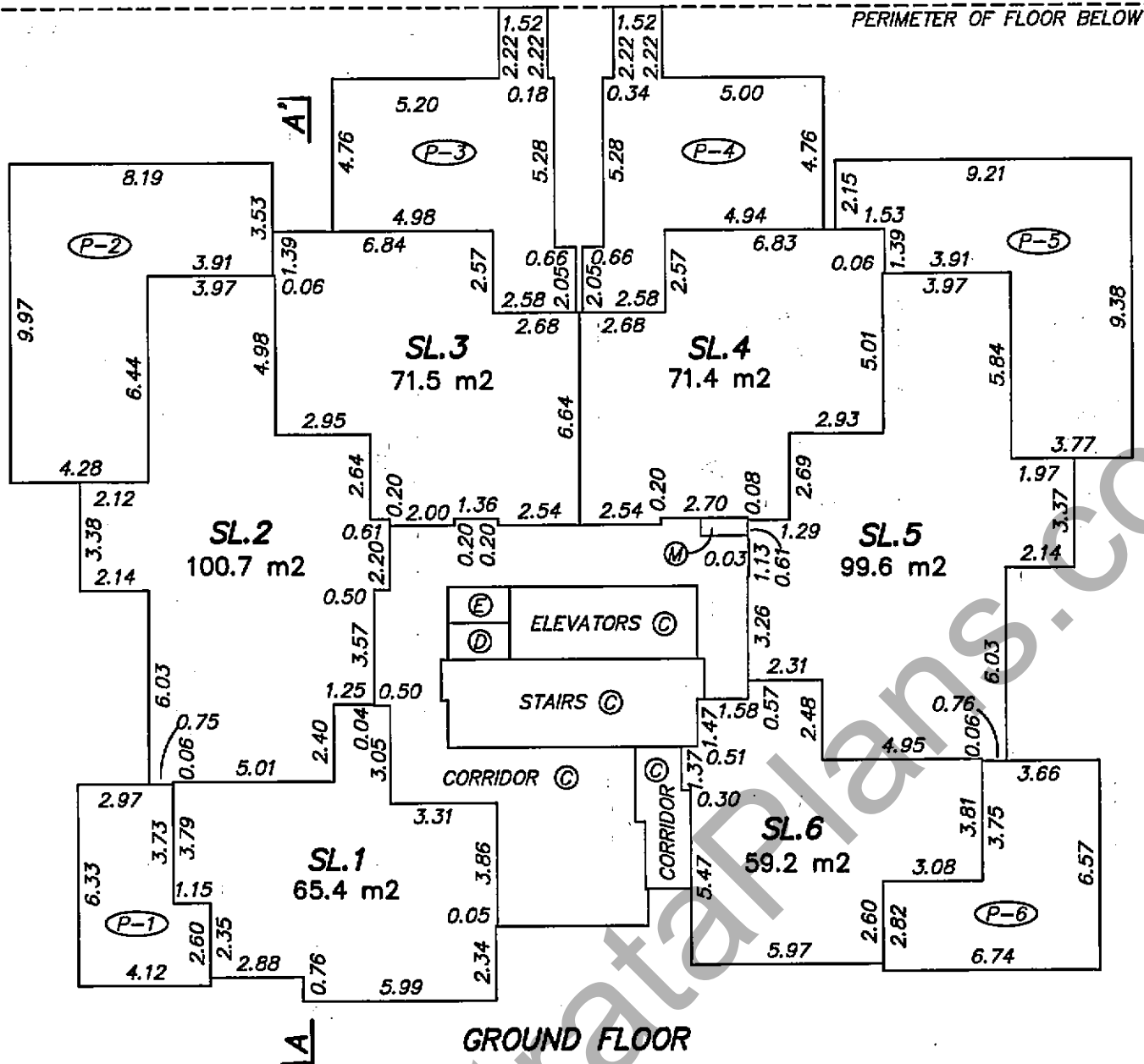

PERIMETER OF FLOOR BELOW

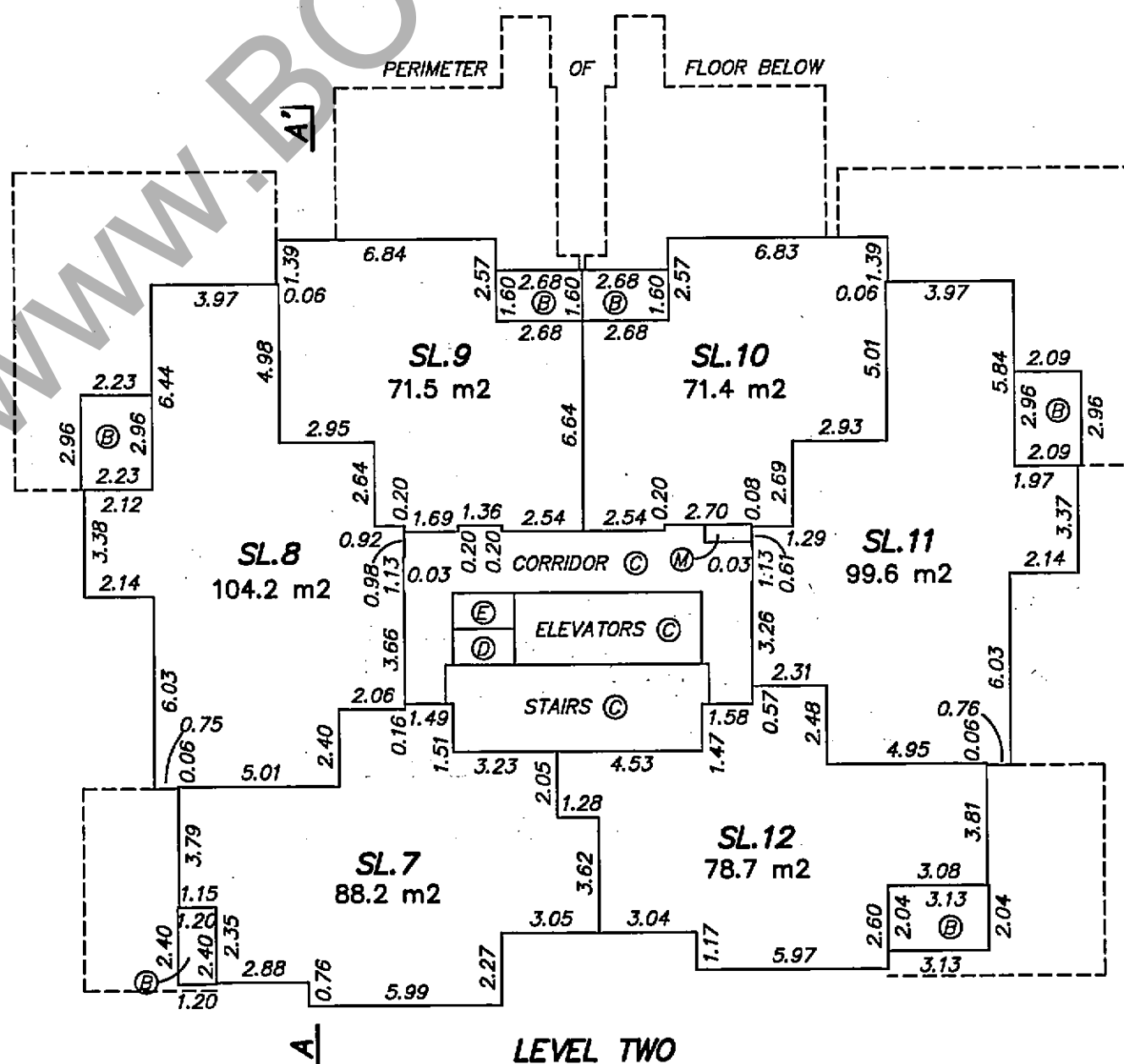

MARCH 11, 2008  
DWG: 3328-ST

ORIGINAL

FILED VABCS2886 RCVD:2008-05-06 ROST:2011-10-31-11.07.08.870

FLOOR PLANS

STRATA PLAN BCS 2886

0 5 10 15

SCALE 1:200 DISTANCES ARE IN METRES



NOTE: LEVEL 4 HAS BEEN ELIMINATED FROM CONSECUTIVE FLOOR NUMBERING

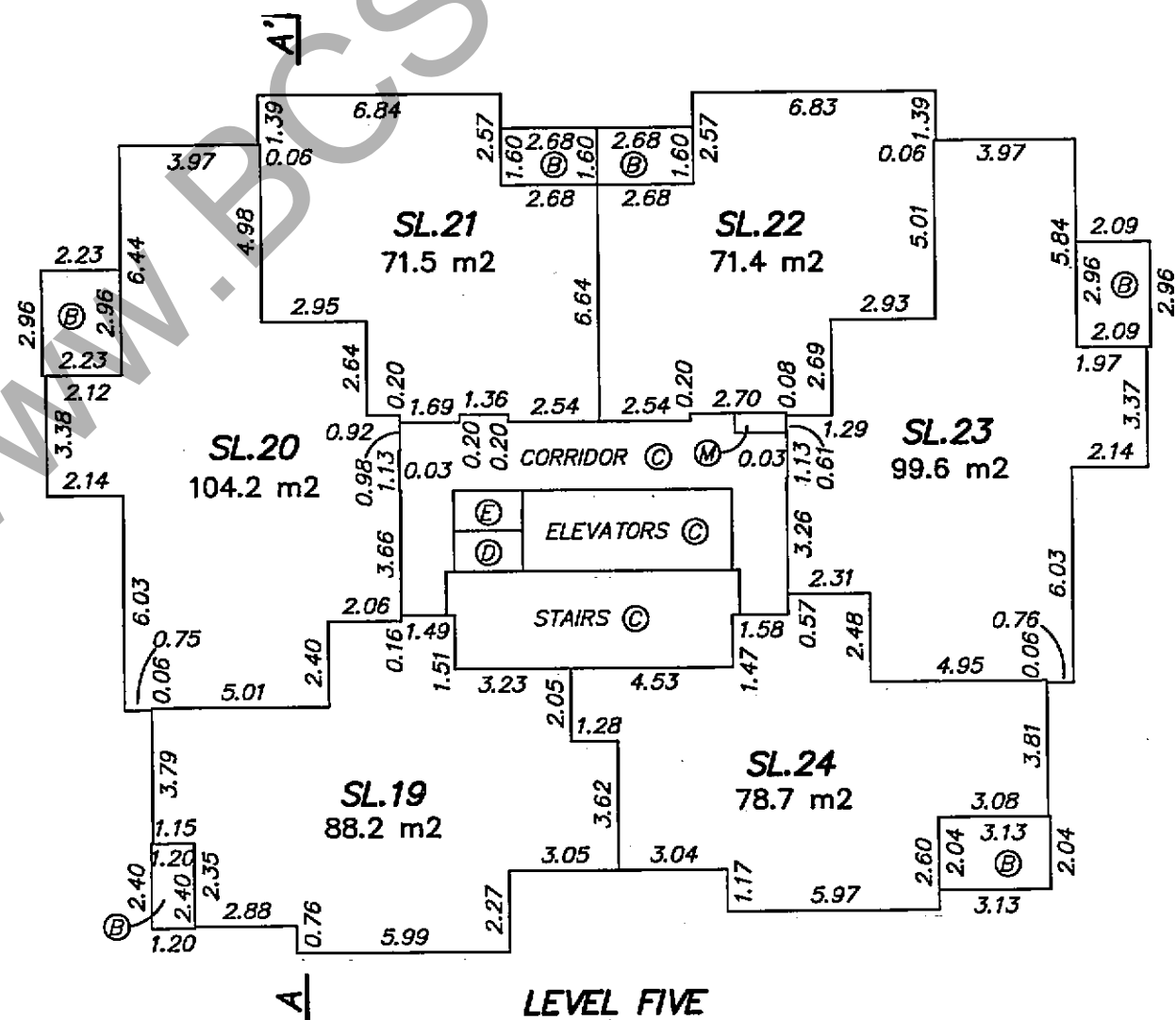
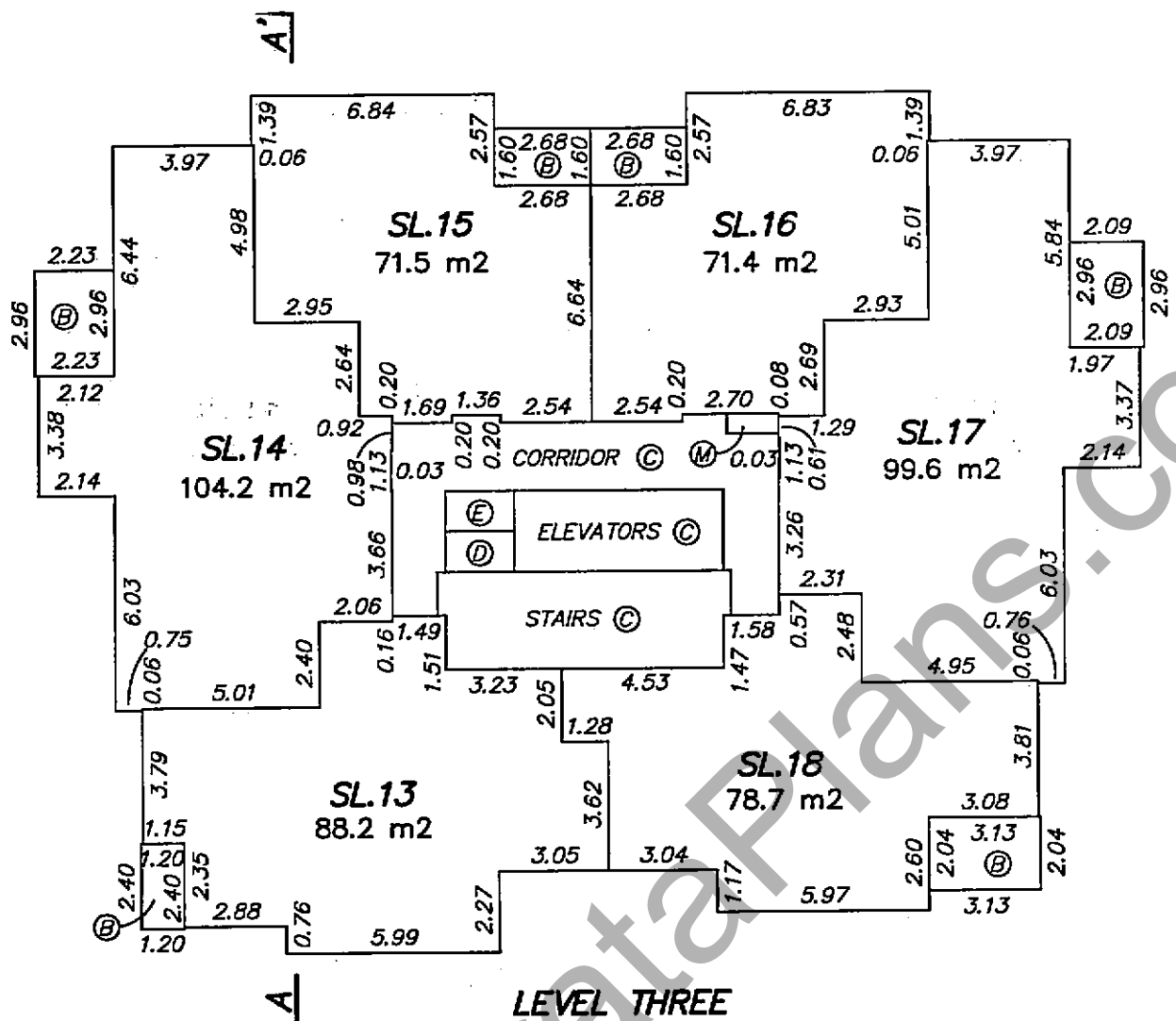

MARCH 11, 2008  
DWG: 3328-ST

ORIGINAL

FLOOR PLANS

STRATA PLAN BCS 2886

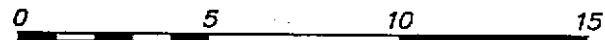

SCALE 1:200 DISTANCES ARE IN METRES

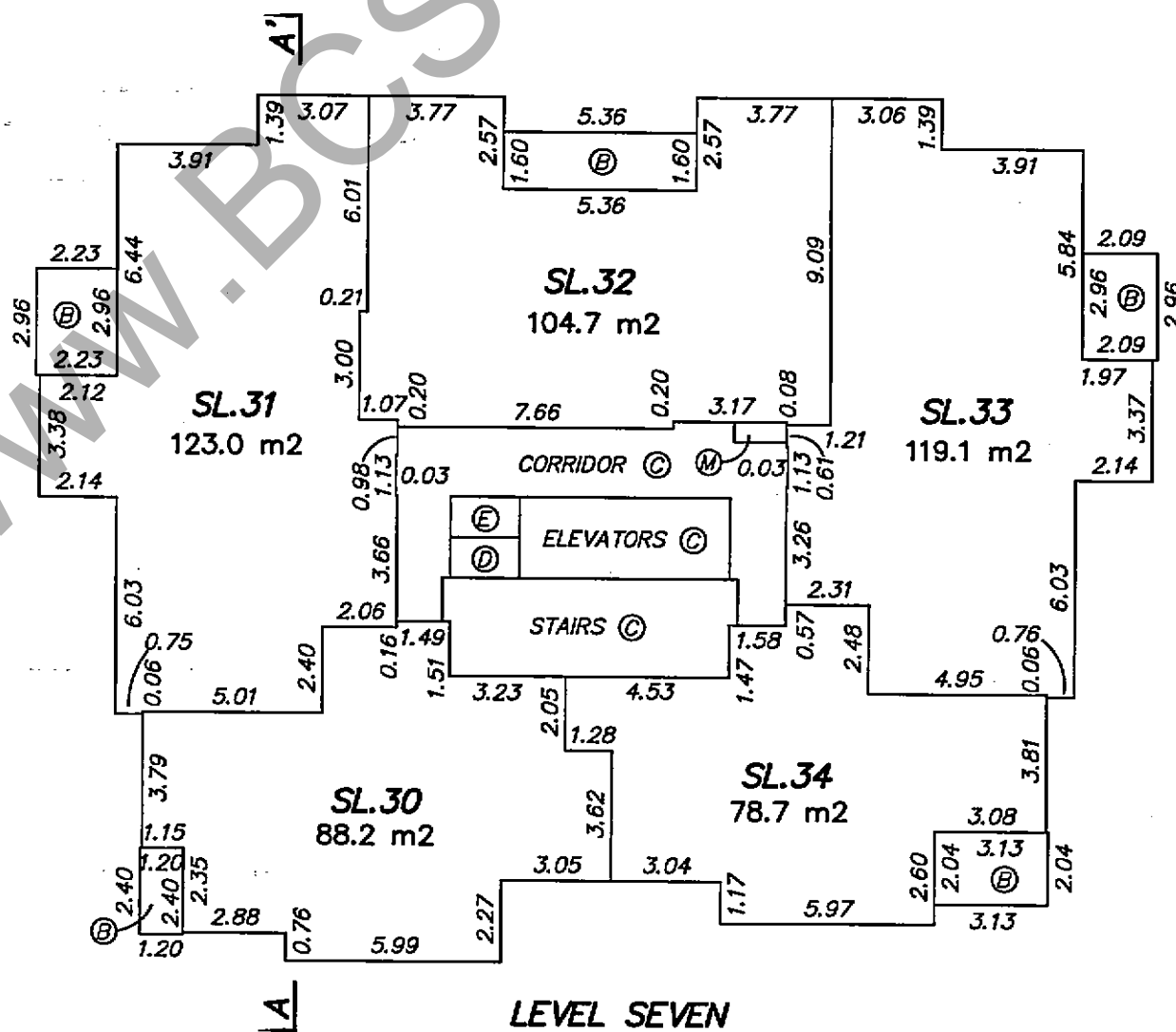
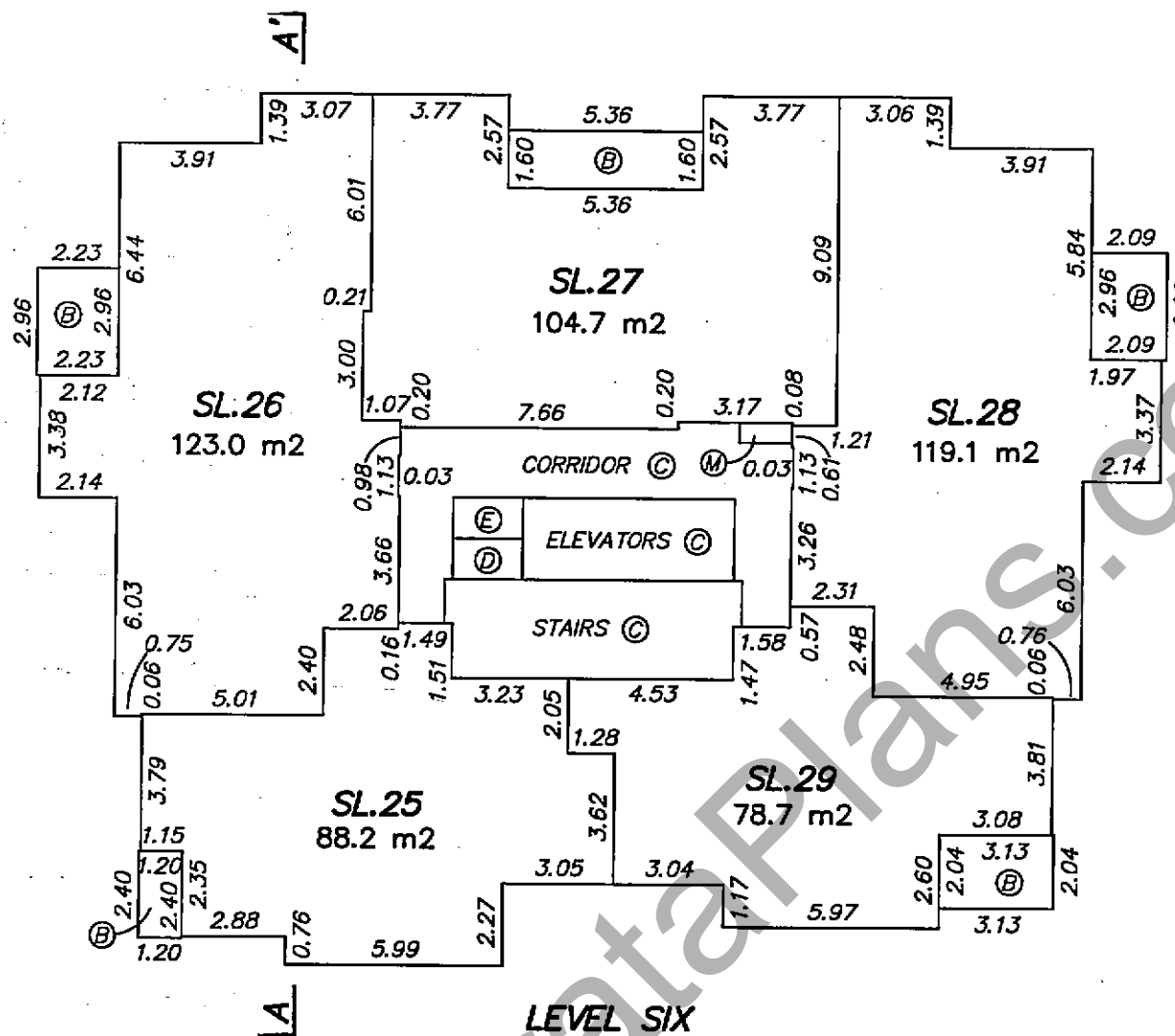

MARCH 11, 2008  
DWG: 3328-ST

ORIGINAL

FLOOR PLANS

STRATA PLAN BCS 2886



SCALE 1:200 DISTANCES ARE IN METRES

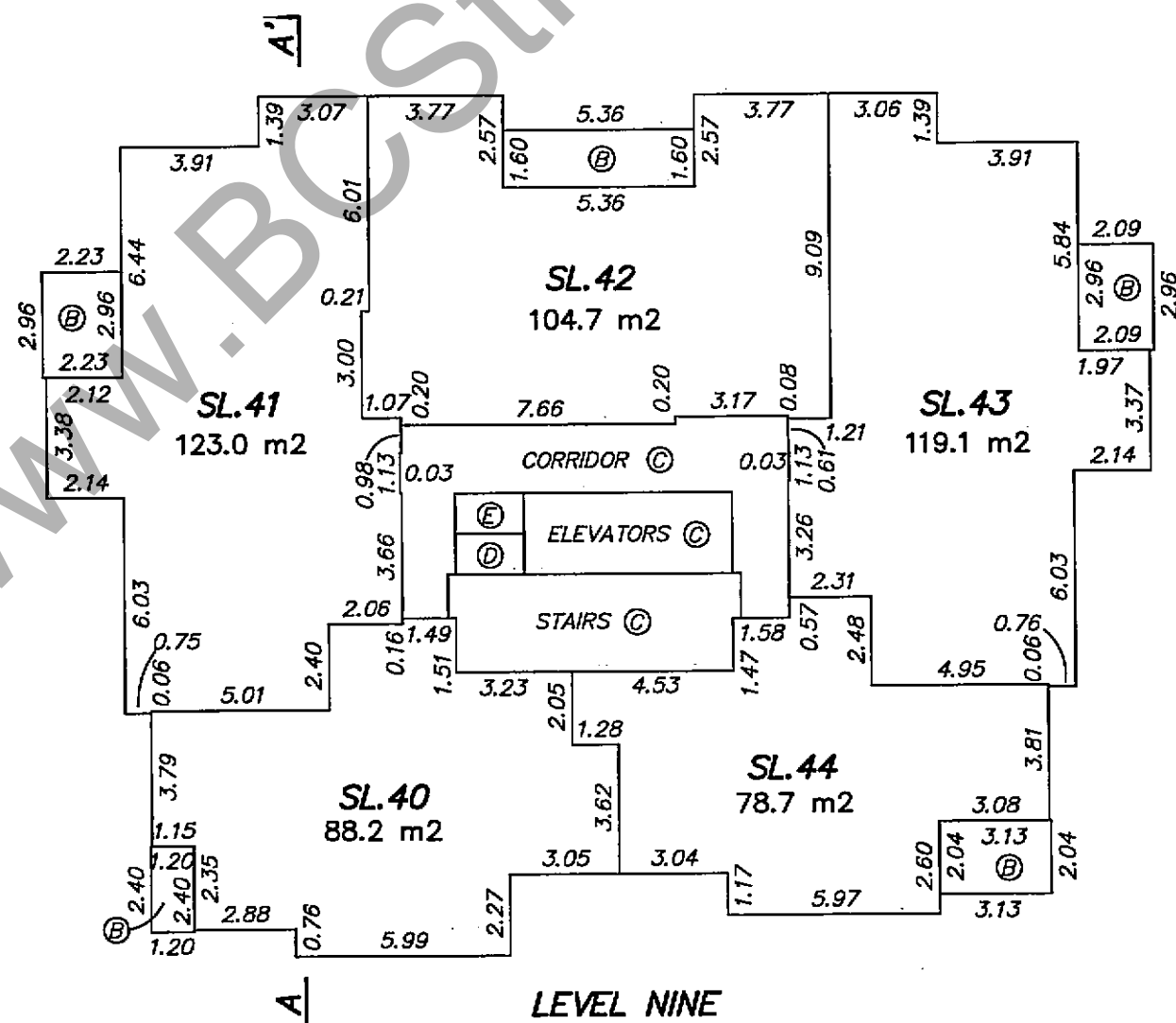
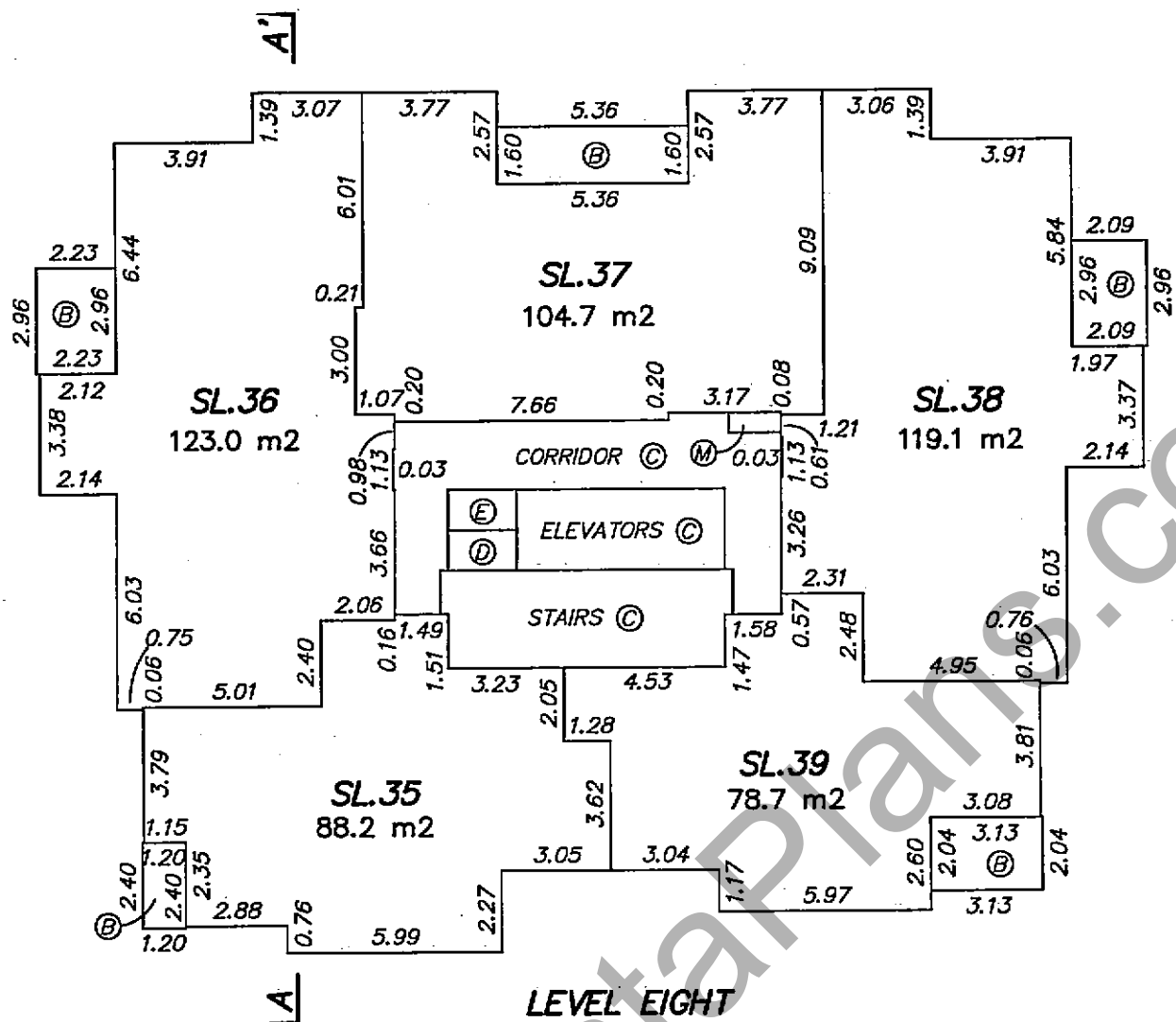

MARCH 11, 2008  
DWG: 3328-ST

ORIGINAL



FLOOR PLANS

STRATA PLAN BCS 2886



SCALE 1:200 DISTANCES ARE IN METRES

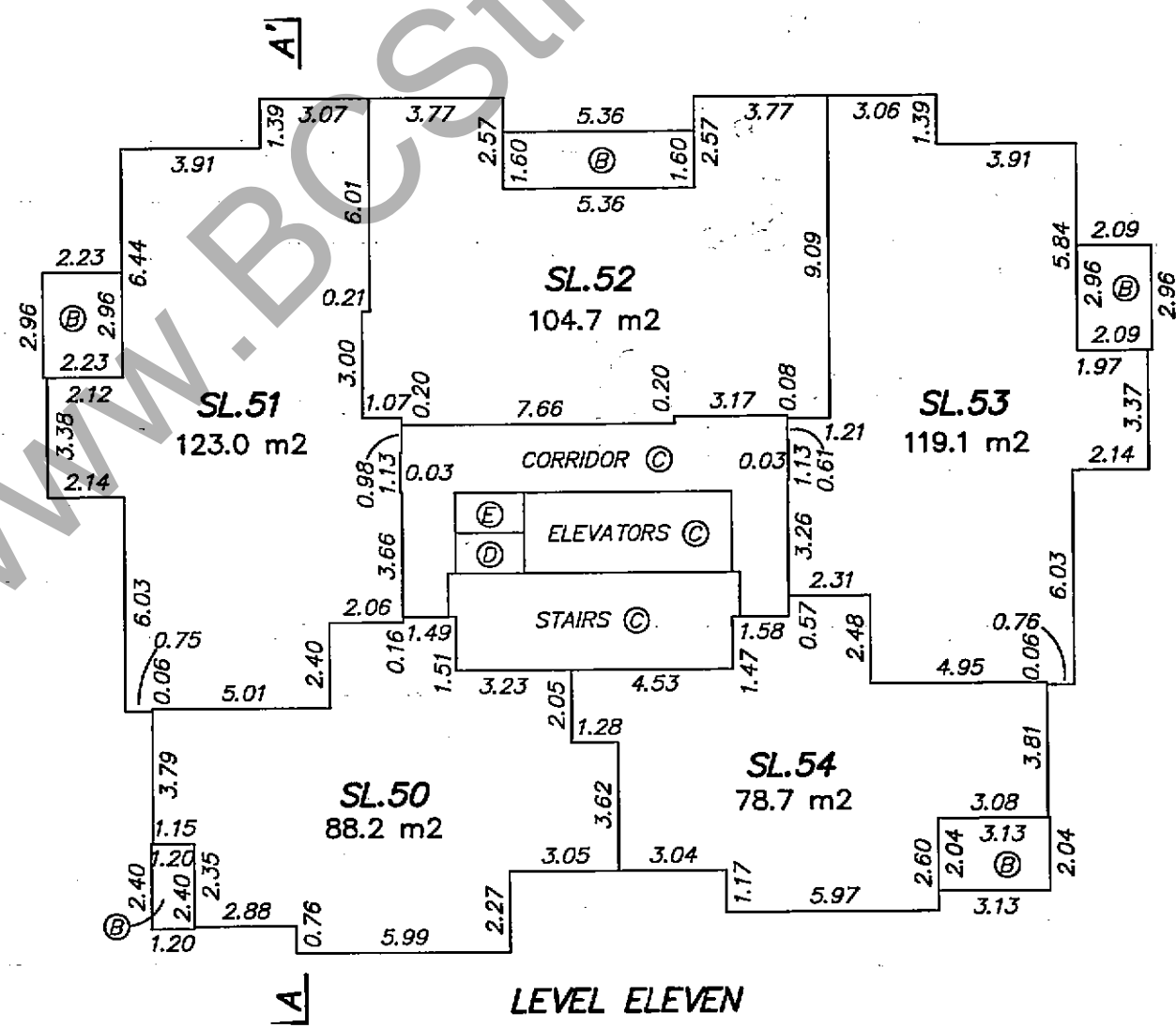
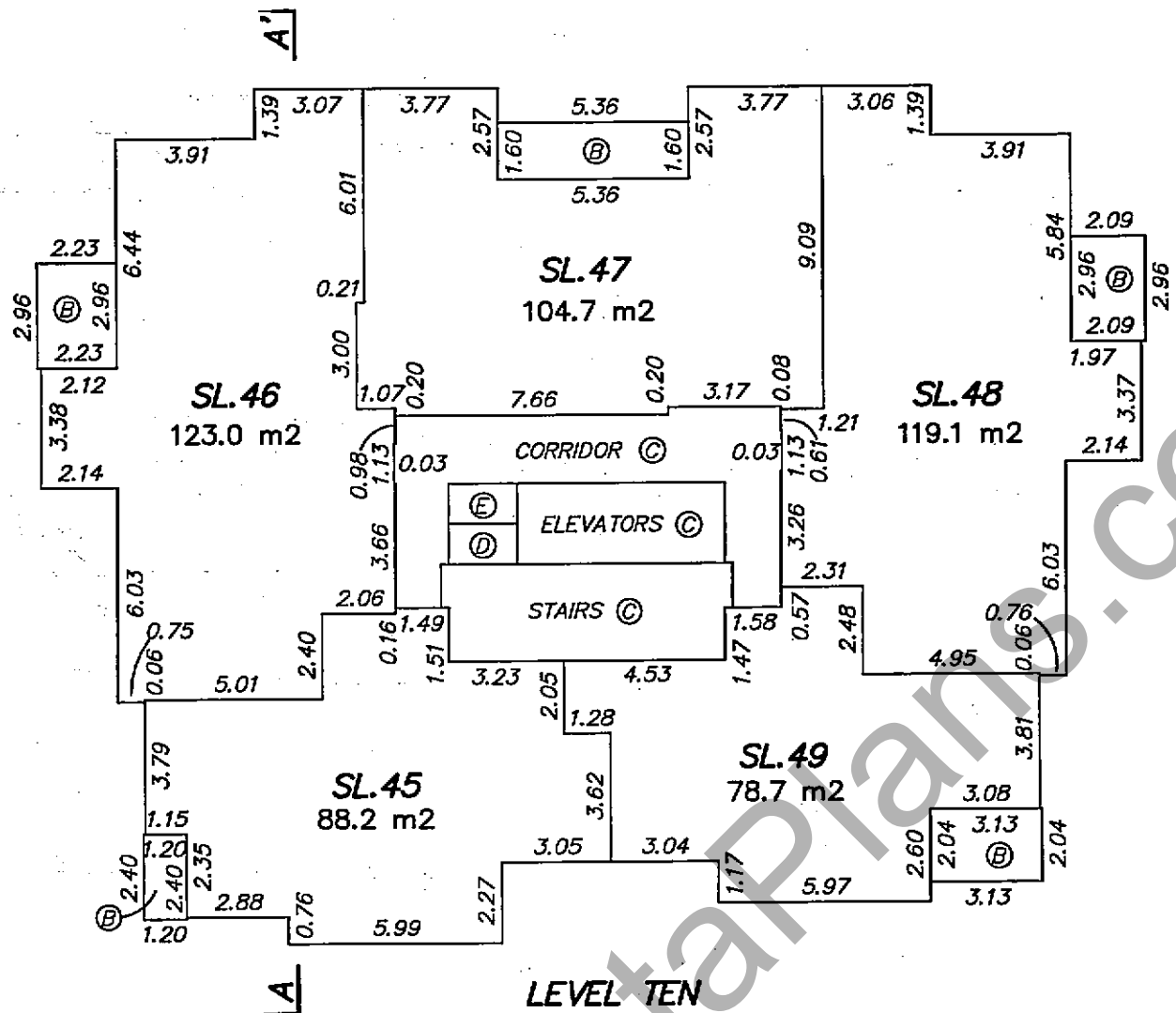
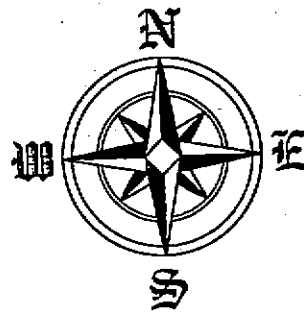

MARCH 11, 2008  
DWG: 3328-ST

ORIGINAL

WWW.BCStrataPlans.com

FILED VABCS2886 RCVD:2008-05-06 ROST:2011-10-31-11.07.08.870

FLOOR PLANS

STRATA PLAN BCS 2886

0 5 10 15  
SCALE 1:200 DISTANCES ARE IN METRES

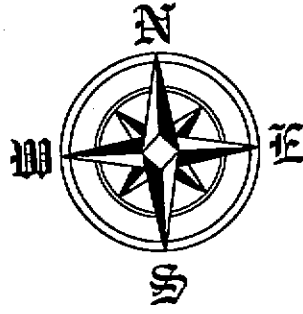

NOTE: LEVELS 13 AND 14 HAVE BEEN ELIMINATED FROM CONSECUTIVE FLOOR NUMBERING

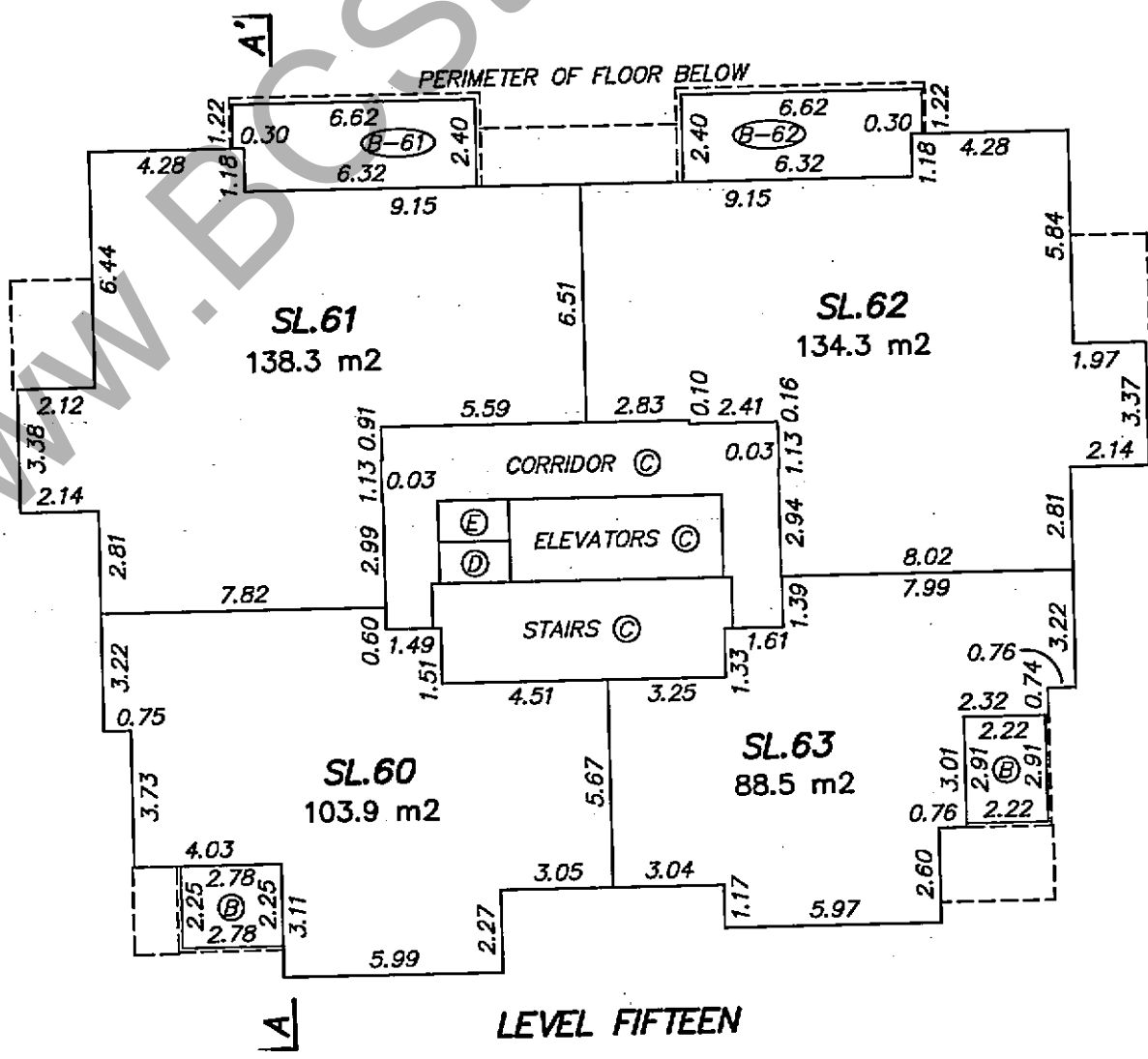
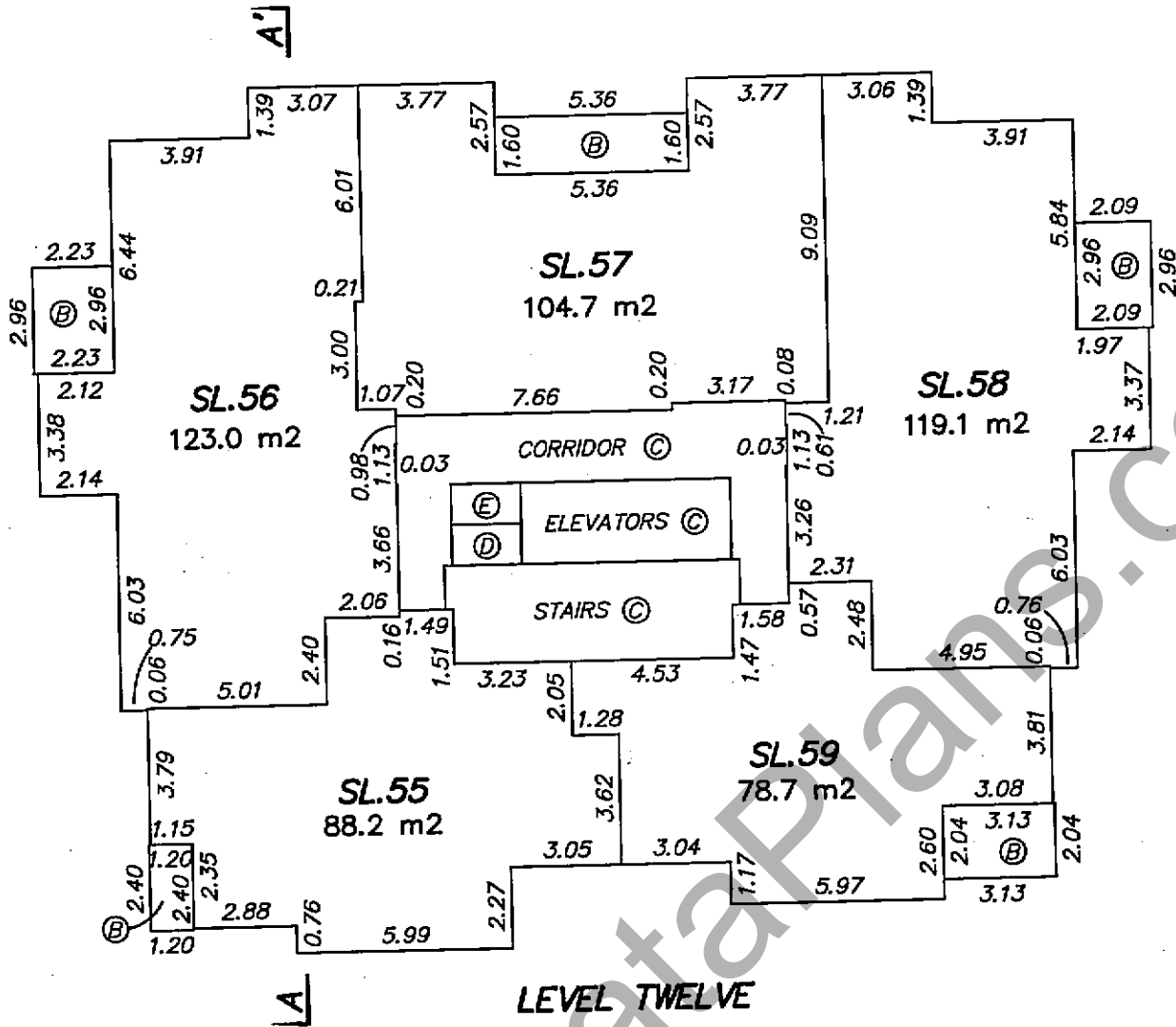

*[Signature]*  
MARCH 11, 2008  
DWG: 3328-ST  
ORIGINAL

FILED VABCS2886 RCVD:2008-05-06 ROST:2011-10-31-11.07.08.870

SECTION

STRATA PLAN BCS 2886



SCALE 1:200 DISTANCES ARE IN METRES

NOTE: LEVELS 4, 13 AND 14 HAVE BEEN ELIMINATED FROM CONSECUTIVE FLOOR NUMBERING

SL.60		SL.61	(B-61)	LEVEL FIFTEEN
SL.55	SL.56			LEVEL TWELVE
SL.50	SL.51			LEVEL ELEVEN
SL.45	SL.46			LEVEL TEN
SL.40	SL.41			LEVEL NINE
SL.35	SL.36			LEVEL EIGHT
SL.30	SL.31			LEVEL SEVEN
SL.25	SL.26			LEVEL SIX
SL.19	SL.20	SL.21		LEVEL FIVE
SL.13	SL.14	SL.15		LEVEL THREE
SL.7	SL.8	SL.9		LEVEL TWO
SL.1	SL.2	SL.3		GROUND FLOOR

EXPLANATORY PLAN BCP36142	©	©	EXPLANATORY PLAN BCP36142	LEVEL P1
---------------------------	---	---	---------------------------	----------

CORRIDOR

SECTION A-A'

MARCH 11, 2008  
DWG: 3328-ST

ORIGINAL

FILED VABCS2886 RCV:2008-05-06 ROST:2011-10-31-11.07.08.870