

**STRATA PLAN OF A PART OF  
LOT A SECTION 32 TOWNSHIP 2  
NWD PLAN BCP44601**

**B.C.G.S. 920.016  
CITY OF SURREY**

**SHEET 1 OF 10 SHEETS**  
**STRATA PL. BCS4200**  
Deposited in the Land Title Office  
at New Westminster B.C. on  
This 22 Day of AUGUST, 2011.



All Distances are in Metres.  
The intended plot size of this plan is  
432mm in width by 280mm in height  
(B size) when platted at a scale of 1:750

**LEGEND:**

- SL Denotes Strata Lot
- PT Denotes Part
- TA Denotes Total Area
- m2 Denotes Square Metres
- LCP Denotes Limited Common Property
- Denotes Standard Iron Post Found
- ⊕ Denotes Common Property
- ⊙ Denotes Common Facility

**PHASE 1**

*L. Blackburn*  
Registrar

Ref. No. FORM 1 - BB 198003  
BB 1980032 - 0060



STRATA PLAN  
LMS4455

STRATA PLAN  
LMS4213

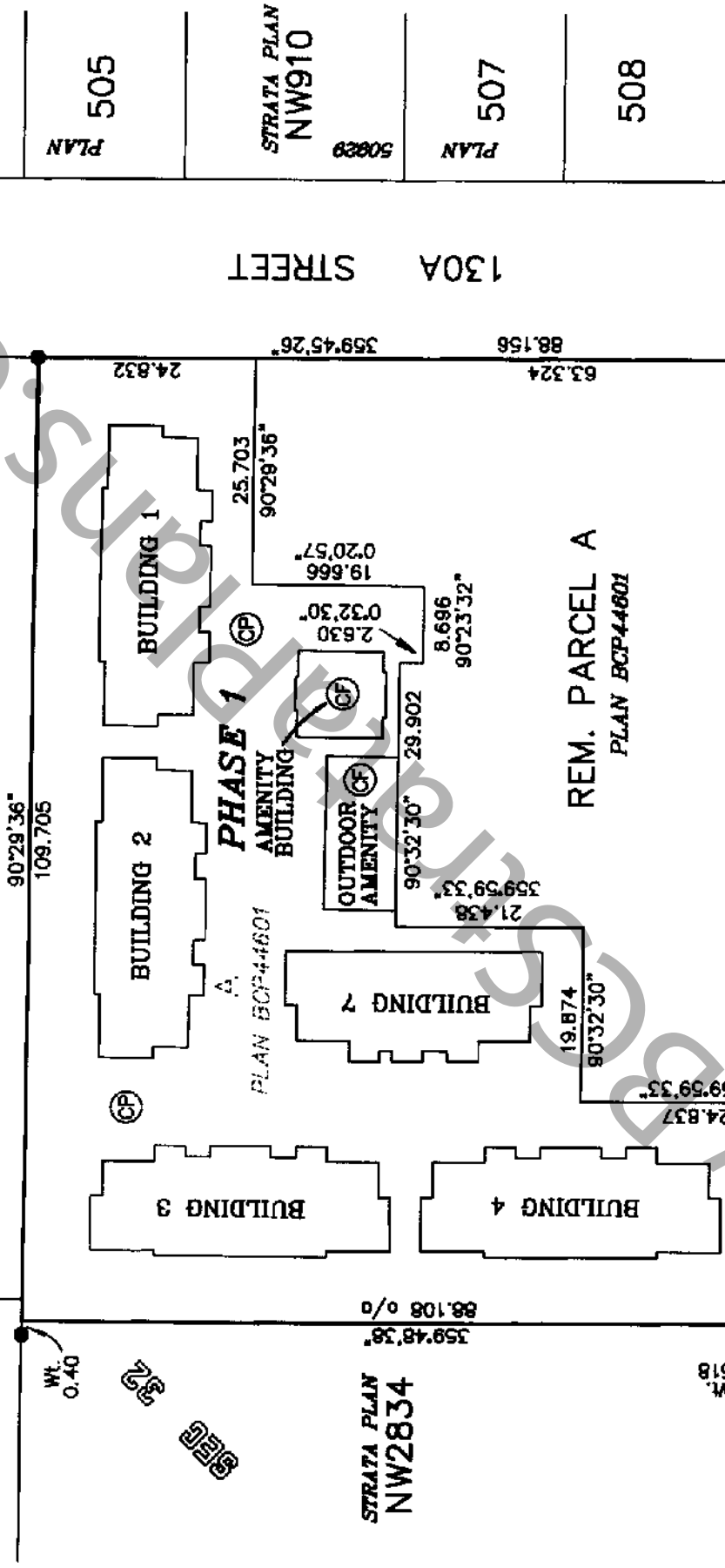

STRATA PLAN  
NW2834

STRATA PLAN  
NW1340

Civic Address:  
9533 130A Street  
Surrey, B.C.

NOTE: Strata lot dimensions are shown  
to outside of exterior walls and  
to centerline of all interior walls.

Grid Bearings are derived from  
Plan BCP44601

**Integrated Survey Area No. 1  
City of Surrey, NAD83 (CSRS)**

This plan shows horizontal ground-level  
measured distances except where otherwise  
noted. To compute grid distances,  
multiply ground-level distances  
by combined factor 0.9995909.

Onderwater Land Surveying  
B.C. Land Surveyors  
#104-6890 176A Street  
Cloverdale B.C.

Inspected under the Land Title Act  
on the 4 Day of August, 2011

*[Signature]*  
Surveyor's Signature

I, John P. Onderwater, a British Columbia Land Surveyor  
certify that I was present at and personally supervised  
the survey represented by this plan, and that the survey  
and plan are correct. The field survey was completed on  
the 6th day of April, 2011. The plan was completed  
and checked, and the checklist filed under  
#121656, on the 7th day of April, 2011.

*[Signature]*  
This Plan Lies Within The  
Greater Vancouver Regional District

FILE: JS1012\_P1\_1



**YARD AREAS**



All Distances are in Metres.  
The intended plot size of this plan is 280mm in width by 432mm in height (B size) when plotted at a scale of 1:400

**LEGEND:**

Y-1 Denotes Yard, LCP of Strata Lot 1 (Typical)

CP Denotes Common Property



**PHASE 1**

STRATA PLAN NW2834

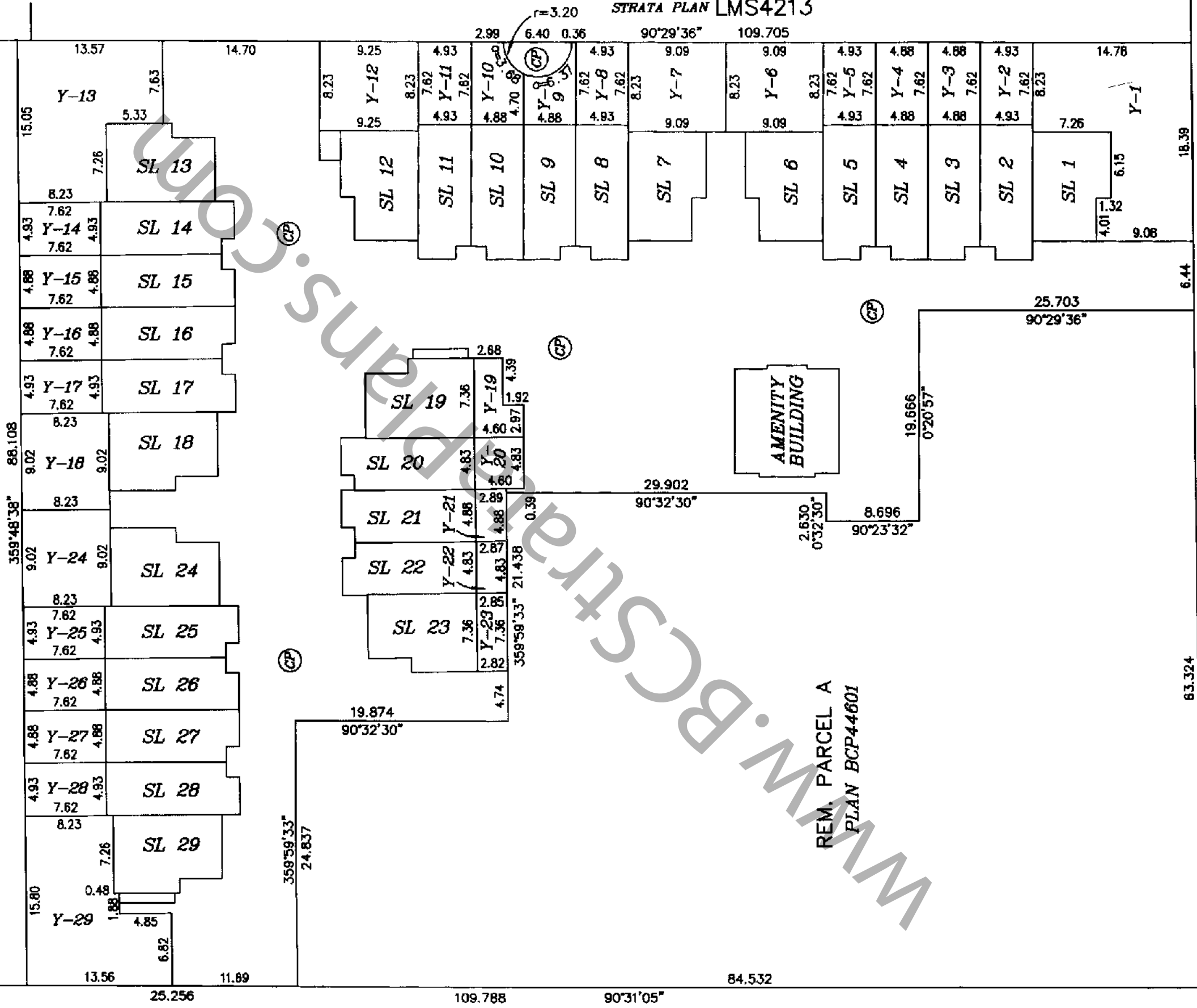

STRATA PLAN NW1340

REM. PARCEL A  
PLAN BCP44601

130A STREET

**SIGNATURES**

**STRATA PLAN BCS 4201**

**OWNER:**  
SURAJ HOME BUILDERS INC.  
(INC. NO. 867412)  
(sign and print name clearly)

**MORTGAGEE:**  
ROYAL BANK OF CANADA  
(sign and print name clearly)

Author Sign  
Kulvir  
AUTHORIZED SIGNATORY

Author Sign  
Seem  
AUTHORIZED SIGNATORY

Author Sign  
AUTHORIZED SIGNATORY

Author Sign  
Sam  
AUTHORIZED SIGNATORY

**DEEPAK A. CHODHA**  
BARRISTER & SOLICITOR  
C. S. LAYERS  
ADDRESS: 6852-176 Street  
Surrey, BC V4W 2A6  
Tel: 604-273-4444  
OCCUPATION OF WITNESS

118-5755-152 no 57 Surrey BC  
ADDRESS OF WITNESS  
Banker  
OCCUPATION OF WITNESS

**FORM R**  
I certify that the Amenity Building, and outdoor amenity, which according to the Phased Strata Plan Declaration in Form P filed for this strata plan, was to have been constructed in conjunction with this phase has been provided for in accordance with section 225 (2) of the Strata Property Act.

Dated this 19<sup>th</sup> day of August, 2011  
[Signature]  
Approving Officer  
City of Surrey

**NICHOLAS LAI**  
APPROVING OFFICER  
CITY OF SURREY

**FORM Q**  
Approved as Phase 1 of a 2 phase strata plan under Section 224 of the Strata Property Act, this 19<sup>th</sup> day of August, 2011.

[Signature]  
Approving Officer  
City of Surrey

**NICHOLAS LAI**  
APPROVING OFFICER  
CITY OF SURREY

**Onderwater Land Surveying**  
B.C. Land Surveyors  
#104 - 5630 176 'A' Street  
Cloverdale, BC  
FILE: JS1012\_P1\_4

**FORM S**  
**NEW DEVELOPMENT CERTIFICATE**  
I, John P. Onderwater, a British Columbia Land Surveyor, certify that the buildings included in this strata plan have not, as of the 7th day of April 2011 been previously occupied.

[Signature]  
B.C.L.S.

I, John P. Onderwater, a British Columbia Land Surveyor, certify that the buildings shown on this strata plan are within the external boundaries of the land that is the subject of the strata plan.

[Signature]  
B.C.L.S.

Dated this 7th day of April, 2011

# FLOOR PLANS BUILDING 1

## PHASE 1

### SHEET 5 OF 10 SHEETS STRATA PLAN BCS 4201



All Distances are in Metres.  
The intended plot size of this plan is  
280mm in width by 432mm in height  
(B size) when plotted at a scale of 1:200

#### LEGEND:

- DE-1 Denotes Deck, LCP of Strata Lot 1 (Typical)
- ENT Denotes Entry, LCP of Strata Lot 1 (Typical)
- ENT-1 Denotes Entry, LCP of Strata Lot 1 (Typical)
- CP Denotes Common Property
- POR-1 Denotes Porch, LCP of Strata Lot 1 (Typical)

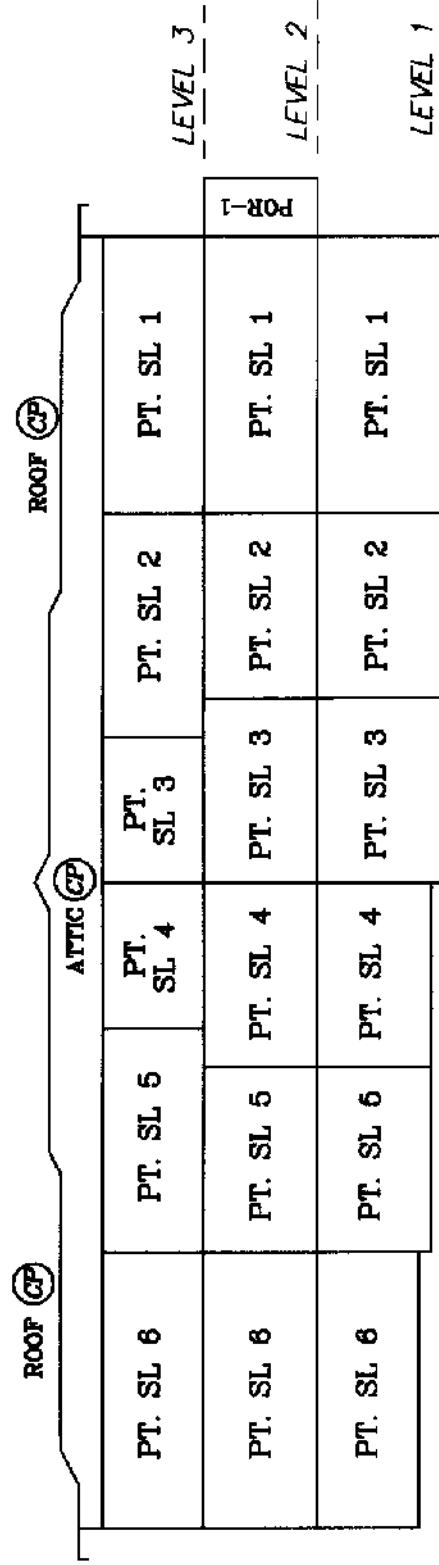
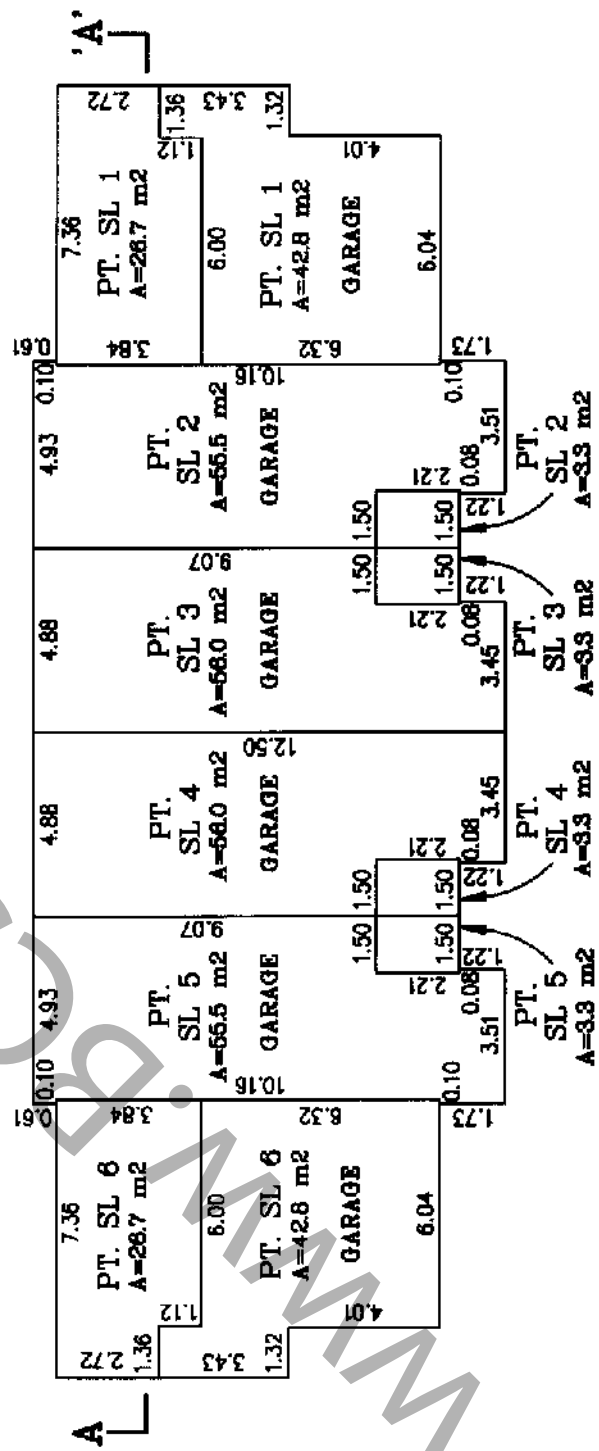
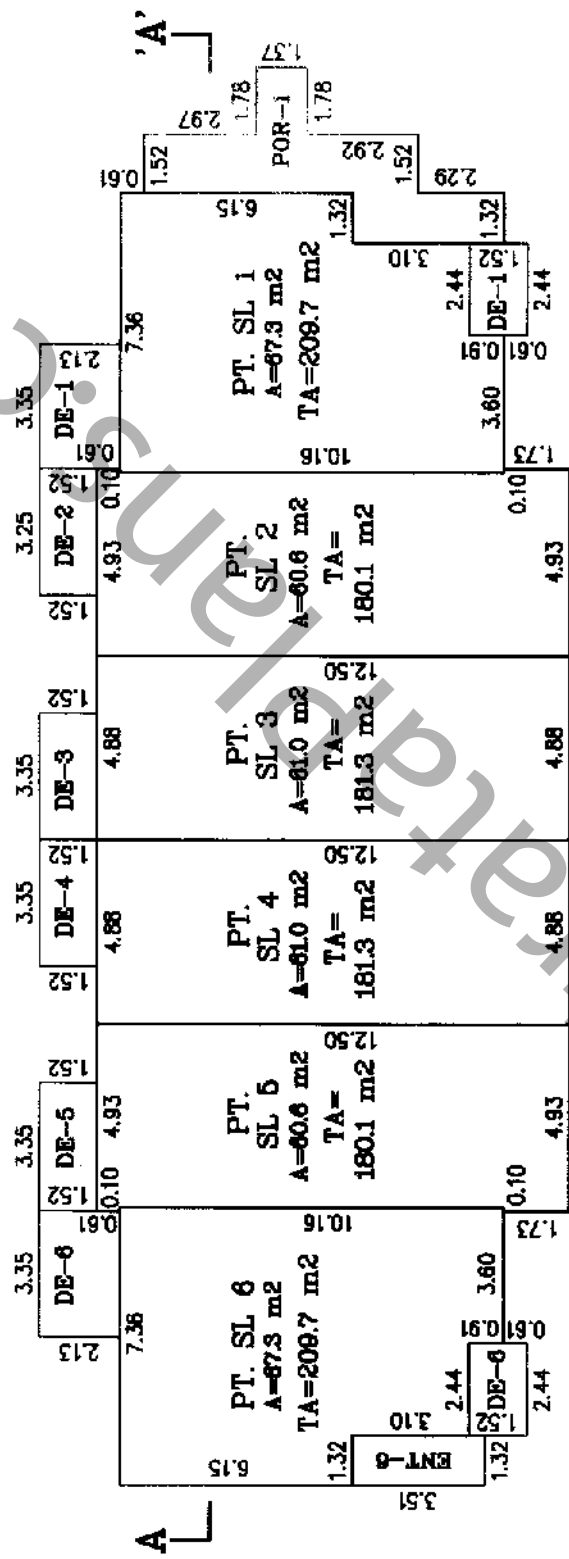
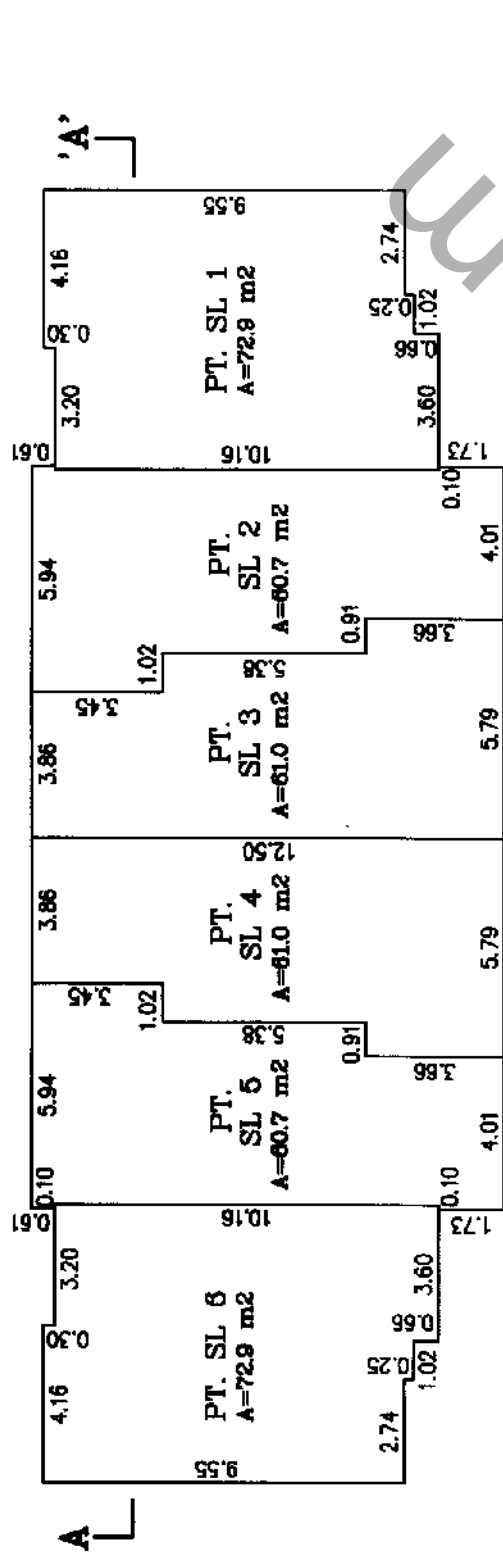



# FLOOR PLANS BUILDING 3

## PHASE 1

### STRATA PLAN BCS 4200



All Distances are in Metres.  
The intended plot size of this plan is  
280mm in width by 432mm in height  
(B size) when plotted at a scale of 1:200



#### LEGEND:

- DE-1 Denotes Deck, LCP of Strata Lot 1 (Typical)
- ENT-1 Denotes Entry, LCP of Strata Lot 1 (Typical)
- POR-1 Denotes Porch, LCP of Strata Lot 1 (Typical)
- CP Denotes Common Property

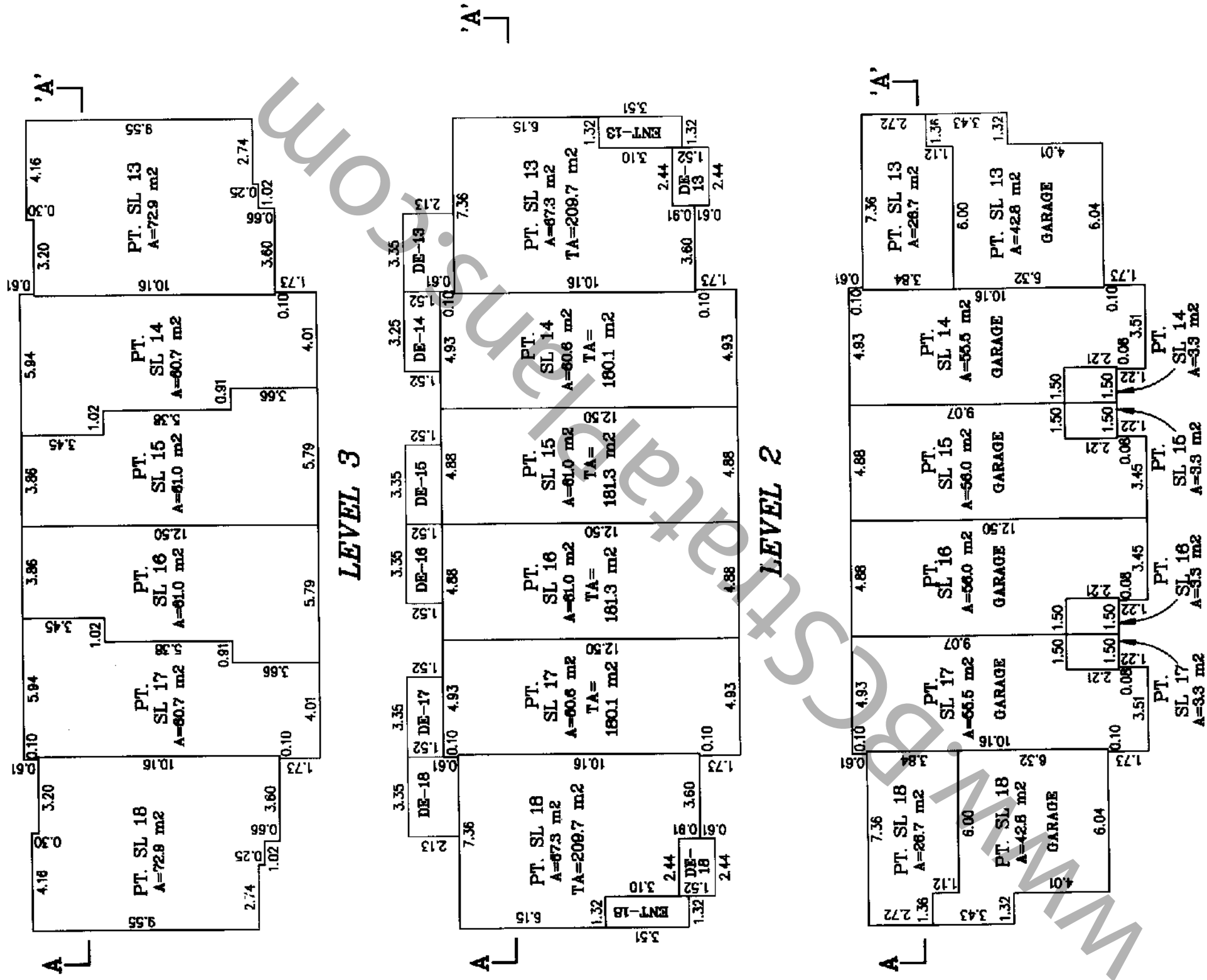

ROOF CP			ATTIC CP			ROOF CP		
PT. SL 18	PT. SL 17	PT. SL 16	PT. SL 15	PT. SL 14	PT. SL 13	LEVEL 3		
PT. SL 18	PT. SL 17	PT. SL 16	PT. SL 15	PT. SL 14	PT. SL 13	LEVEL 2		
PT. SL 18	PT. SL 17	PT. SL 16	PT. SL 15	PT. SL 14	PT. SL 13	LEVEL 1		

# FLOOR PLANS BUILDING 7 PHASE 1 STRATA PLAN BCS 4200



All Distances are in Metres.  
The intended plot size of this plan is 280mm in width by 432mm in height (B size) when plotted at a scale of 1:200



**LEGEND:**  
DE-1 Denotes Deck, LCP of Strata Lot 1 (Typical)  
CP Denotes Common Property

ENT-1 Denotes Entry, LCP of Strata Lot 1 (Typical)  
POR-1 Denotes Porch, LCP of Strata Lot 1 (Typical)

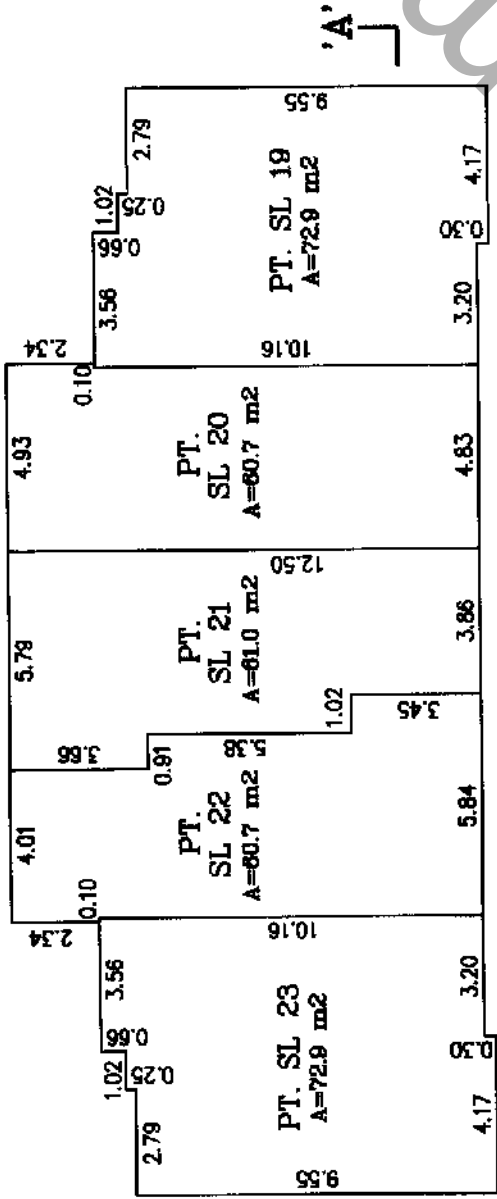

## LEVEL 3

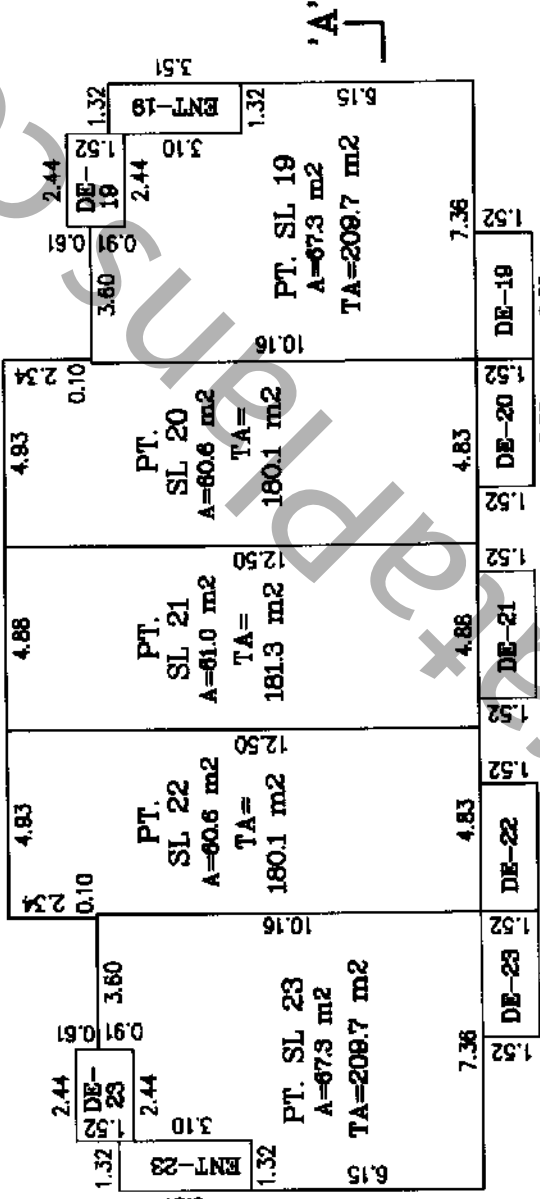

## LEVEL 2

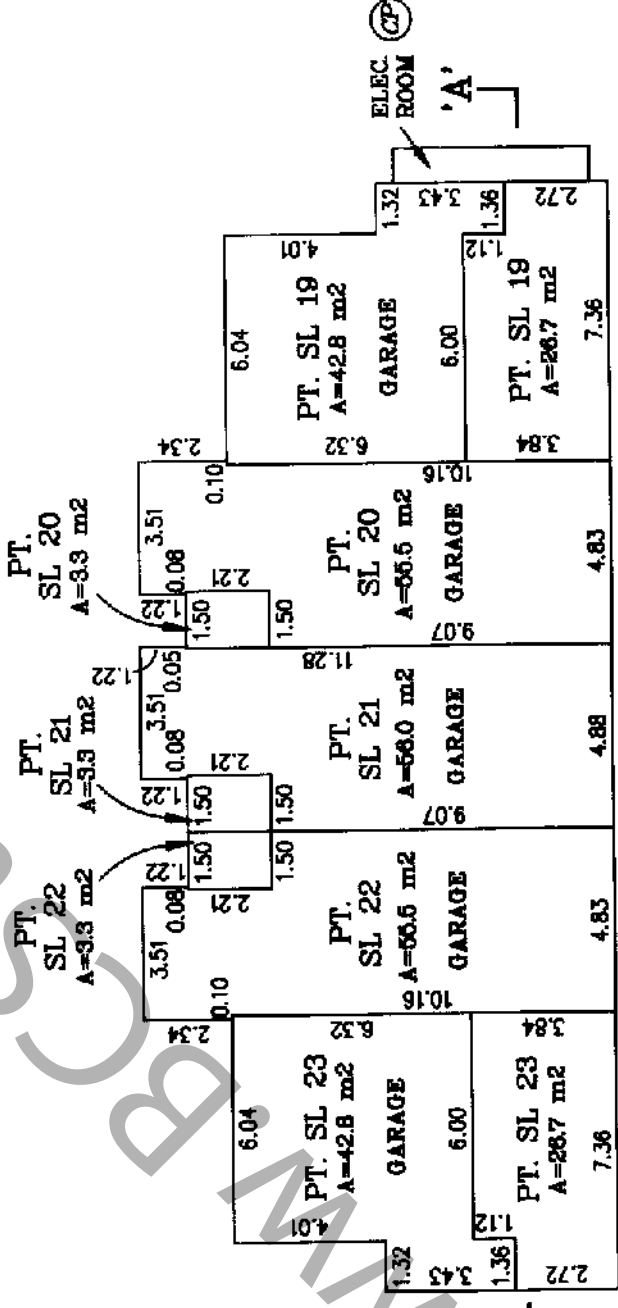

## LEVEL 1

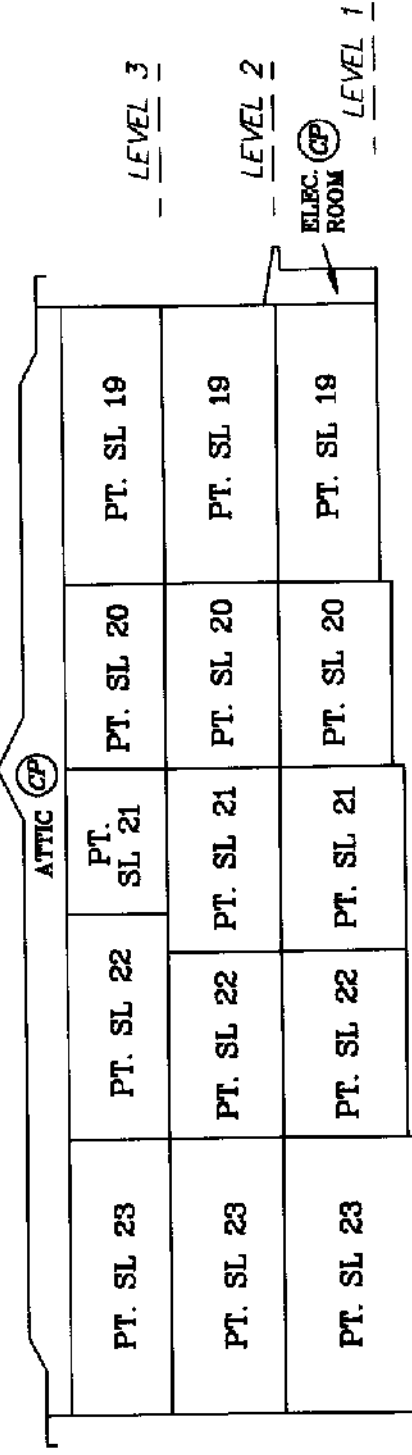





# FLOOR PLANS AMENITY BUILDING

## PHASE 1

COMMON FACILITY



All Distances are in Metres.  
 The intended plot size of this plan is  
 280mm in width by 432mm in height  
 (B size) when plotted at a scale of 1:200

