

**STRATA PLAN OF LOT A SECTION 26 TOWNSHIP 2
NEW WESTMINSTER DISTRICT PLAN BCP31213**

BCGS 92G.017

SCALE 1:600

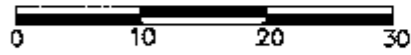

ALL DIMENSIONS ARE IN METRES

THIS PLAN SHOWS HORIZONTAL GROUND-LEVEL DISTANCES EXCEPT WHERE OTHERWISE NOTED. TO COMPUTE GRID DISTANCES, MULTIPLY GROUND-LEVEL DISTANCES BY COMBINED FACTOR 0.99959405

GRID BEARINGS ARE DERIVED FROM OBSERVATIONS BETWEEN CONTROL MONUMENTS 5272 AND 5258, INTEGRATED SURVEY AREA NO. 1 CITY OF SURREY, B.C. DATUM: NAD83 (CSRS) - 2005

LEGEND

- ⊙ INDICATES CONTROL MONUMENT FOUND
- INDICATES STANDARD IRON POST FOUND
- INDICATES STANDARD IRON POST PLACED
- ⊕ INDICATES COMMON PROPERTY
- Ⓜ INDICATES LIMITED COMMON PROPERTY FOR RESIDENTIAL
- Ⓝ INDICATES LIMITED COMMON PROPERTY FOR COMMERCIAL
- V INDICATES VENT
- ELEC. INDICATES ELECTRICAL
- MECH. INDICATES MECHANICAL
- COR. INDICATES CORRIDOR

BALCONY, PATIO, AND YARD AREAS ARE DEFINED AS TO HEIGHT BY THE CENTRE OF THE FLOOR ABOVE OR ITS EXTENSIONS, OR WHERE THERE IS NO FLOOR ABOVE BY THE AVERAGE HEIGHT OF STRATA LOTS WITHIN THE SAME BUILDING, UNLESS OTHERWISE NOTED.

**H.Y. AND ASSOCIATES
LAND SURVEYING LTD.**

200, 9128 - 152 STREET
SURREY, B.C.
V3R 4E7
(ph) 583-1616
(fx) 583-1737
Job: 052264LS
File: 052264_PG1.DWG

PARKING, PATIO, YARD, AND BALCONY AREAS ARE LIMITED COMMON PROPERTIES FOR THE USE OF THE STRATA LOT INDICATED (eg: PK-1, P-4, Y-9, B-3)

THIS PLAN LIES WITHIN THE GREATER VANCOUVER REGIONAL DISTRICT - CITY OF SURREY

STRATA LOT MEASUREMENTS ARE 90° OR 45° UNLESS NOTED OTHERWISE.

STRATA LOT DIMENSIONS ARE MEASURED TO:

- CENTERLINE OF EXTERIOR WALLS
- CENTERLINE OF PARTY WALLS
- OUTSIDE FACE OF ELEVATOR WELL

STRATA PLAN BCS4280

REF. NO. BB1354250-4305

DEPOSITED IN THE LAND TITLE OFFICE AT NEW WESTMINSTER, B.C.

THIS 17th DAY OF NOV, 2011.

L. B. Beachuk
REGISTRAR

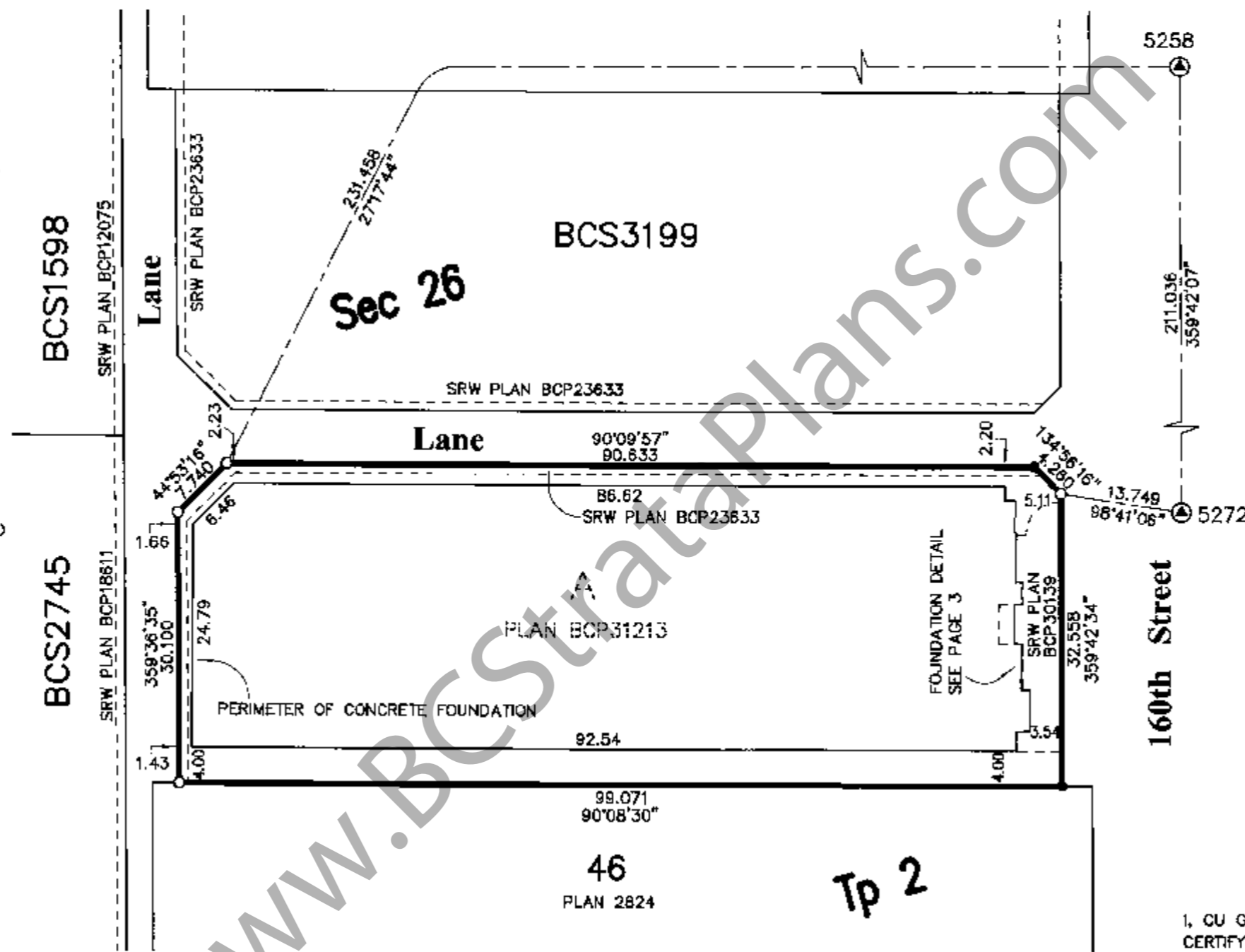

CIVIC ADDRESS:

8695 - 160th STREET
SURREY, BC

I, GU GORDON YU, A BRITISH COLUMBIA LAND SURVEYOR, CERTIFY THAT I WAS PRESENT AT AND PERSONALLY SUPERINTENDED THE SURVEY REPRESENTED BY THIS PLAN, AND THAT THE SURVEY AND PLAN ARE CORRECT. THE FIELD SURVEY WAS COMPLETED ON THE 28th DAY OF OCTOBER, 2011. THE PLAN WAS COMPLETED AND CHECKED, AND THE CHECKLIST FILED UNDER #129585, ON THE 7th DAY OF NOVEMBER, 2011.

Gordon

B.C.L.S.

STRATA PLAN BCS 4280

STRATA PROPERTY ACT FORM S

ENDORSEMENT OF NONOCCUPANCY

(SECTION 241, REGULATIONS SECTION 14.5(3))

I, GU GORDON YU, A BRITISH COLUMBIA LAND SURVEYOR, CERTIFY THAT THE BUILDING INCLUDED IN THIS STRATA PLAN HAS NOT, AS OF NOVEMBER 7, 2011, BEEN PREVIOUSLY OCCUPIED.

Gordon

SIGNATURE

OWNER

PIONEER DESIGNS (MONTEROSSO) CORP.
INC. NO. 0706110

[Signature]

AUTHORIZED SIGNATORY

LEEBY METHERAL

PRINT NAME

AUTHORIZED SIGNATORY

[Signature]

PRINT NAME

WITNESS AS TO BOTH SIGNATURES

Madrice E.L. Lambert

PRINT NAME OF WITNESS

500-5811 Cooney Rd.

OCCUPATION OF WITNESS

*Richmond, B.C.
Solicitor*

ADDRESS OF WITNESS

STRATA PROPERTY ACT

FORM U

ENDORSEMENT OF SURVEYOR

(SECTION 244(1)(f); REGULATIONS SECTION 14.5(5))

I, GU GORDON YU, A BRITISH COLUMBIA LAND SURVEYOR, CERTIFY THAT THE BUILDING SHOWN ON THIS STRATA PLAN IS WITHIN THE EXTERNAL BOUNDARIES OF THE LAND THAT IS THE SUBJECT OF THE STRATA PLAN.

DATE: NOVEMBER 7, 2011

Gordon

SIGNATURE

MORTGAGEE

ROYAL BANK OF CANADA

AUTHORIZED SIGNATORY

[Signature] *RON ALBERT*
83005

PRINT NAME

AUTHORIZED SIGNATORY

[Signature] *Peter Sohn Claasen*

PRINT NAME

WITNESS AS TO BOTH SIGNATURES

Donna Adams

PRINT NAME OF WITNESS

Banker

OCCUPATION OF WITNESS

118-5455-152nd St., Surrey, B.C.

ADDRESS OF WITNESS

V2S 5A5

THE CITY OF SURREY AS HOLDER OF COVENANTS:

BB426091 AND BB426093,

HEREBY CONSENTS TO THE FILING

OF THIS STRATA PLAN.

MAYOR: DIANNE WATTS

[Signature]

CITY CLERK:

[Signature]

H.Y. AND ASSOCIATES
LAND SURVEYING LTD.

200, 9128 - 152 STREET

SURREY, B.C.

V3R 4E7

(PH) 583-1616

(FX) 583-1737

Job: 052264LS

File: 052264_PG2.DWG

DATE: NOVEMBER 7, 2011

Gordon

B.C.L.S.

FOUNDATION DETAILS

SHEET 3 OF 17 SHEETS
STRATA PLAN BCS 4280

SCALE 1:100



All distances are in metres.

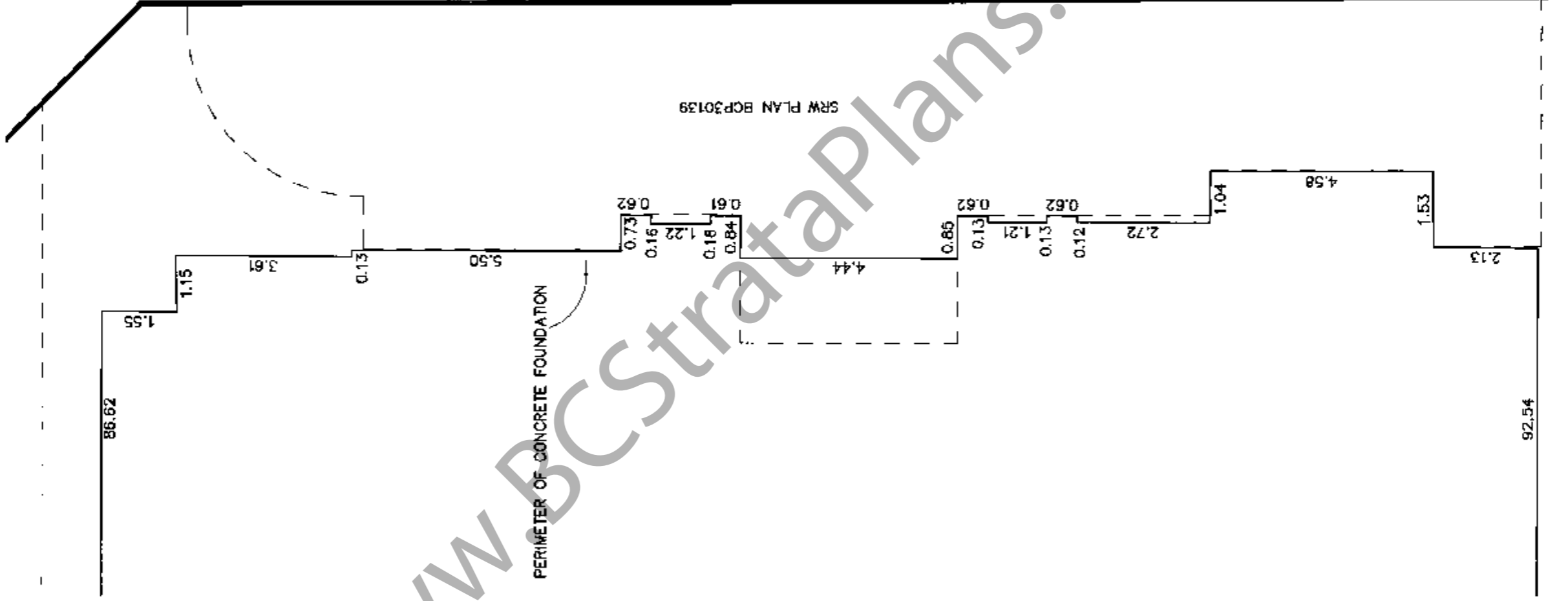

H.Y. AND ASSOCIATES
LAND SURVEYING LTD.

200, 9128 - 152nd STREET
SURREY, B.C.

V3R 4E7

(ph) 583-1616

(fx) 583-1737

Job : 052264LS

File: 052264_PC3.DWG

DATE: NOVEMBER 7, 2011

B.C.L.S.

UNDERGROUND PARKING (EAST)

STRATA PLAN BCS 4280

SCALE 1:200



All distances are in metres.

SEE PAGE 5
MATCH LINE

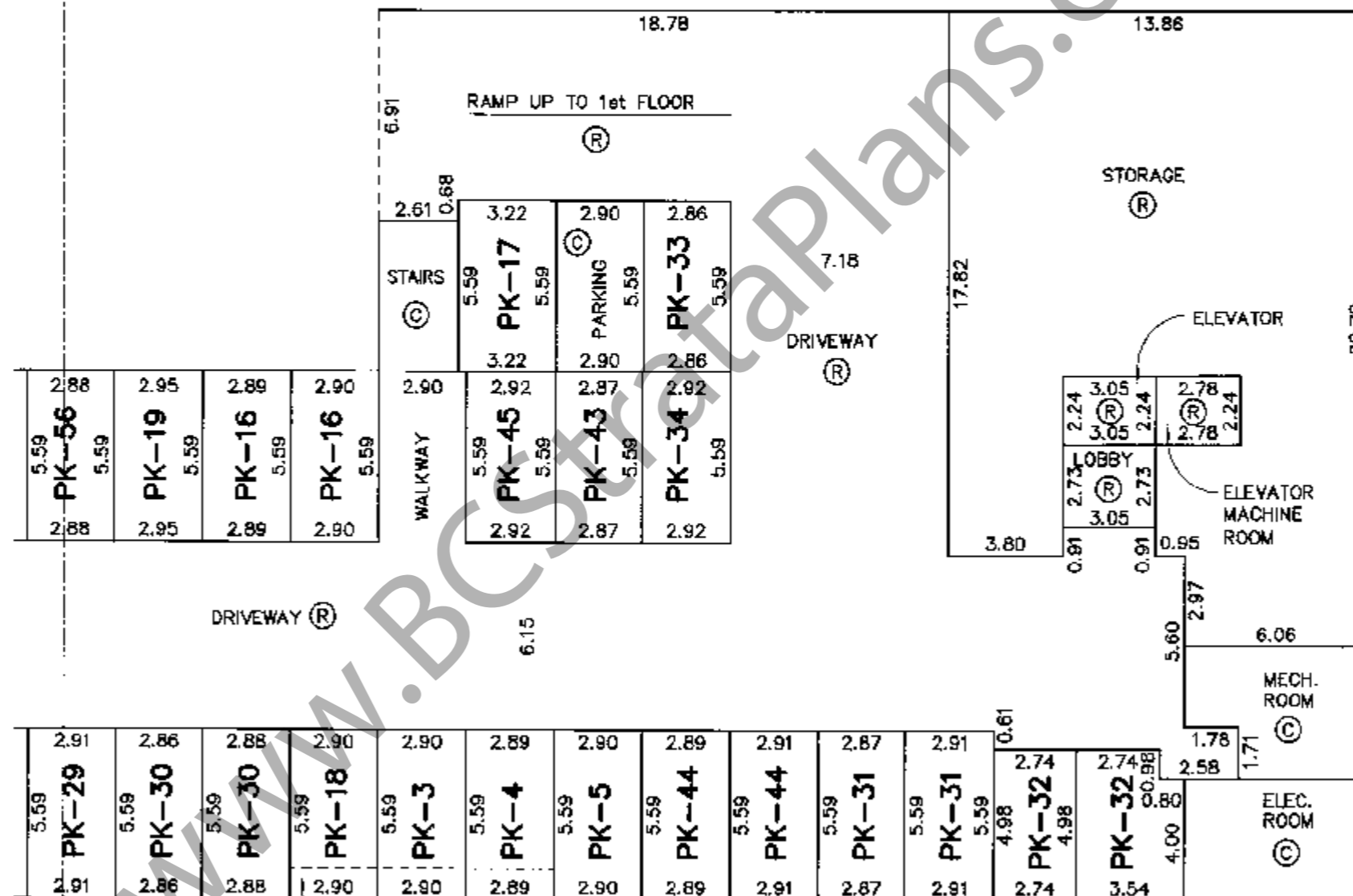

**H.Y. AND ASSOCIATES
LAND SURVEYING LTD.**

200, 9128 - 152nd STREET
SURREY, B.C.

V3R 4E7

(ph) 583-1616

(fx) 583-1737

Job : 052264LS

File: 052264_UG_E.DWG

EXHAUST AND DUCT
1.8m ABOVE

CENTERLINE OF CONCRETE WALL

DATE: NOVEMBER 7, 2011

B.C.L.S.

UNDERGROUND PARKING (WEST)

STRATA PLAN BCS 4280

SCALE 1:200



All distances are in metres.

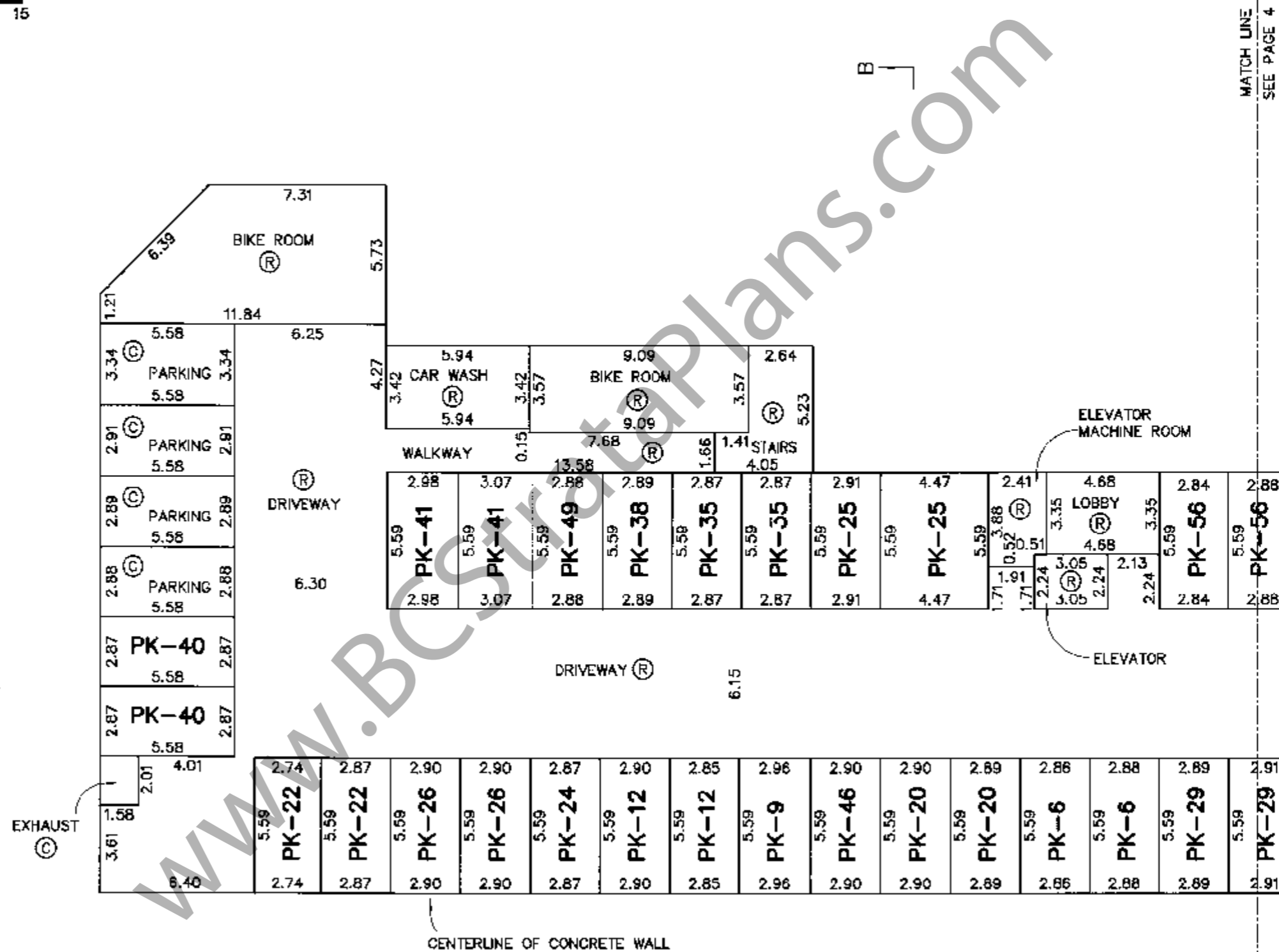

**H.Y. AND ASSOCIATES
LAND SURVEYING LTD.**

200, 9128 - 152nd STREET
SURREY, B.C.

V3R 4E7

(ph) 583-1618

(fx) 583-1737

Job : 052264LS

File: 052264_UG_W.DWG

DATE: NOVEMBER 7, 2011

B.C.L.S.

1st FLOOR (EAST)

STRATA PLAN BCS 1250

SCALE 1:200



All distances are in metres.

SEE PAGE 7
MATCH LINE

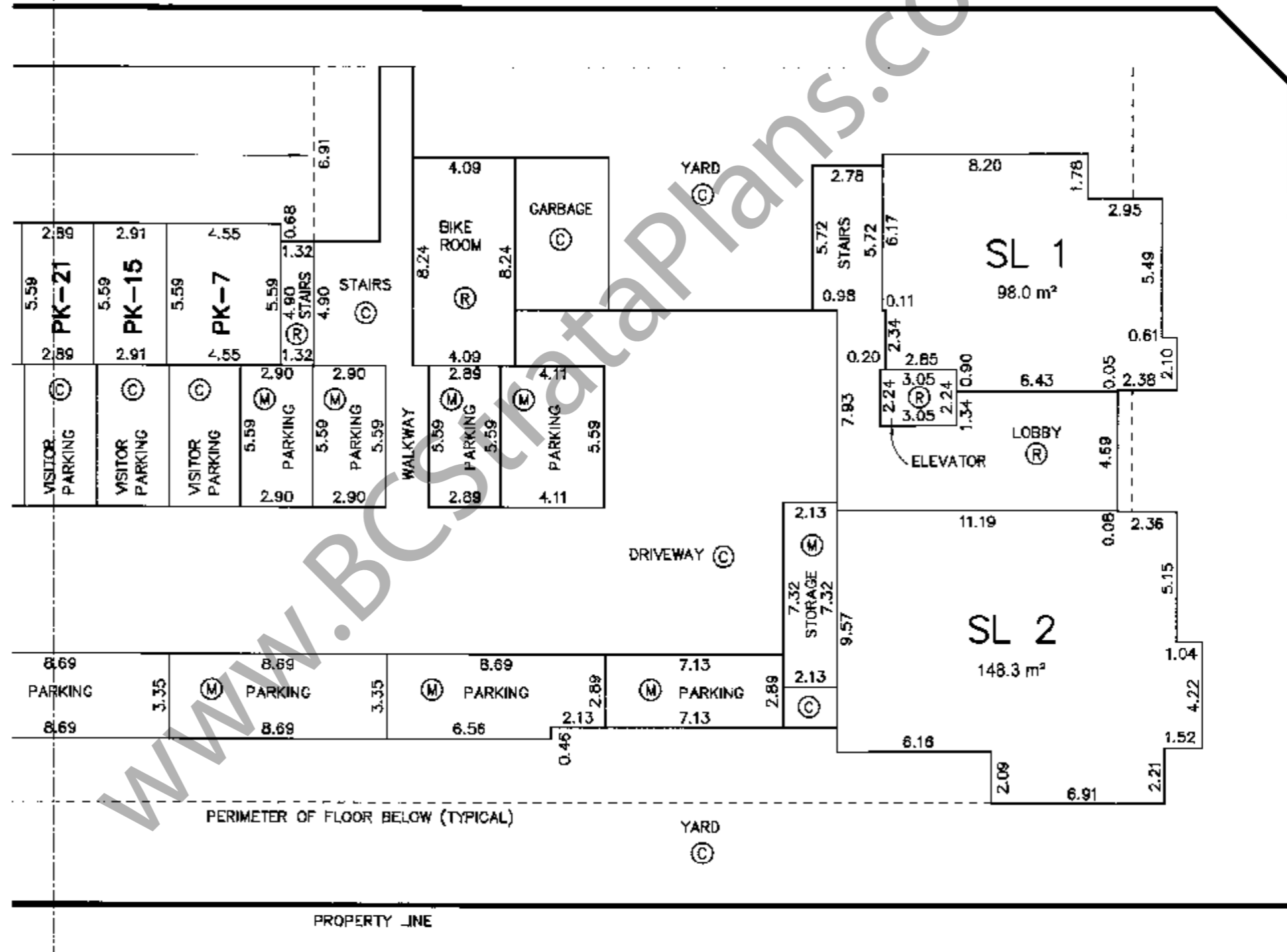

**H.Y. AND ASSOCIATES
LAND SURVEYING LTD.**

200, 9128 - 152nd STREET
SURREY, B.C.

V3R 4E7

(ph) 583-1616

(fx) 583-1737

Job : 052264LS

File: 052264_1_E.DWG

DATE: NOVEMBER 7, 2011

B.C.L.S.

ORIGINAL

2nd FLOOR (EAST)

STRATA PLAN BCS 4280

SCALE 1:200



All distances are in metres.

ELEVATOR, CORRIDOR, STAIRS, ELECTRICAL CLOSET (ELEC.), VENT, AND AMENITY ROOM SHOWN ON THIS PAGE ARE RESIDENTIAL LIMITED COMMON PROPERTIES

SEE PAGE 9 MATCH LINE

PERIMETER OF FLOOR BELOW (TYPICAL)



A

A

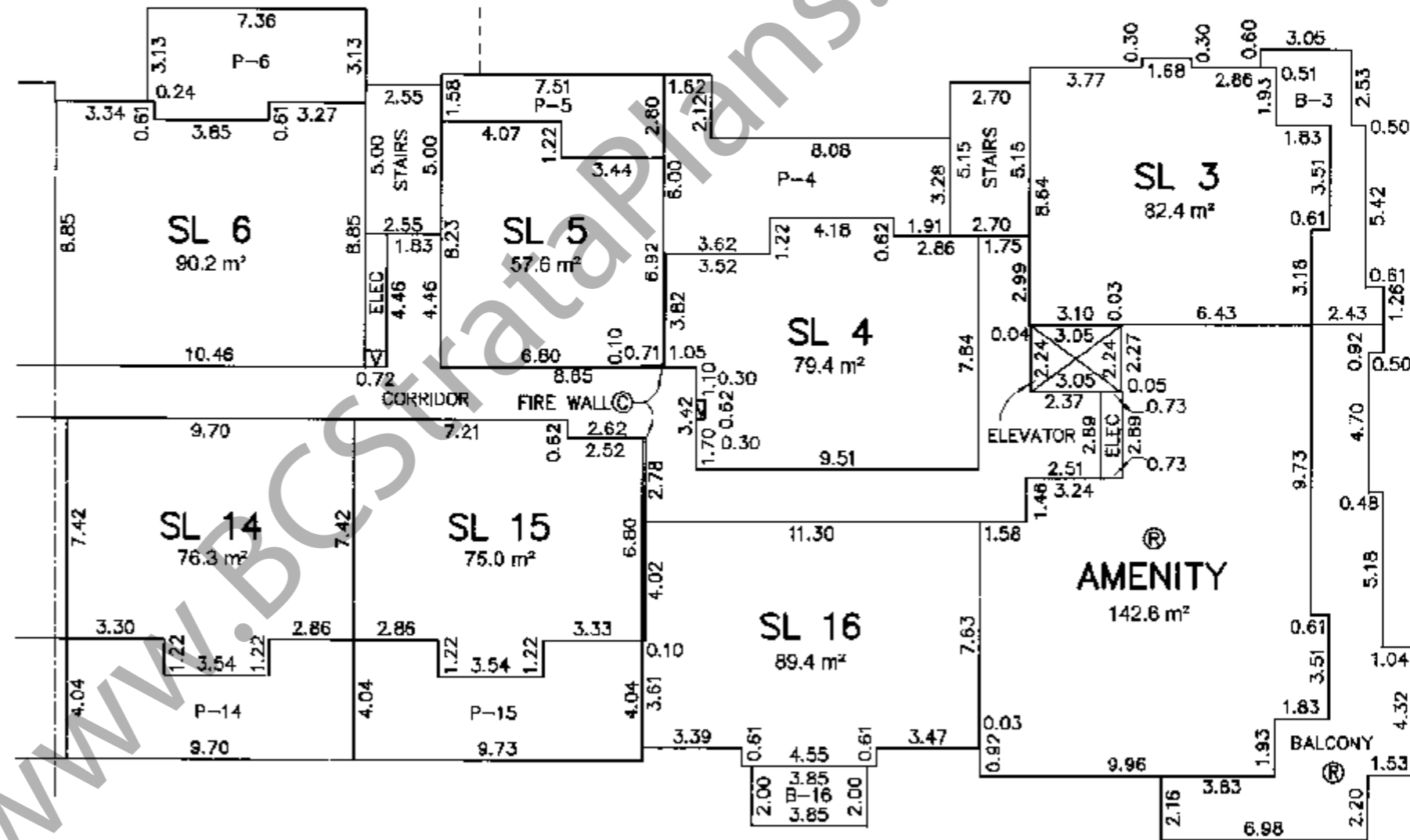

**H.Y. AND ASSOCIATES
LAND SURVEYING LTD.**

200, 9128 - 152nd STREET
SURREY, B.C.

V3R 4E7

(ph) 583-1616

(fx) 583-1737

Job : 052264LS

File: 052264_2_E.DWG

DATE: NOVEMBER 7, 2011

B.C.L.S.

3rd FLOOR (EAST)

STRATA PLAN BCS 4280

SCALE 1:200



All distances are in metres.

ELEVATOR, CORRIDOR, STAIRS, ELECTRICAL CLOSET (ELEC.), AND VENT, SHOWN ON THIS PAGE ARE RESIDENTIAL LIMITED COMMON PROPERTIES

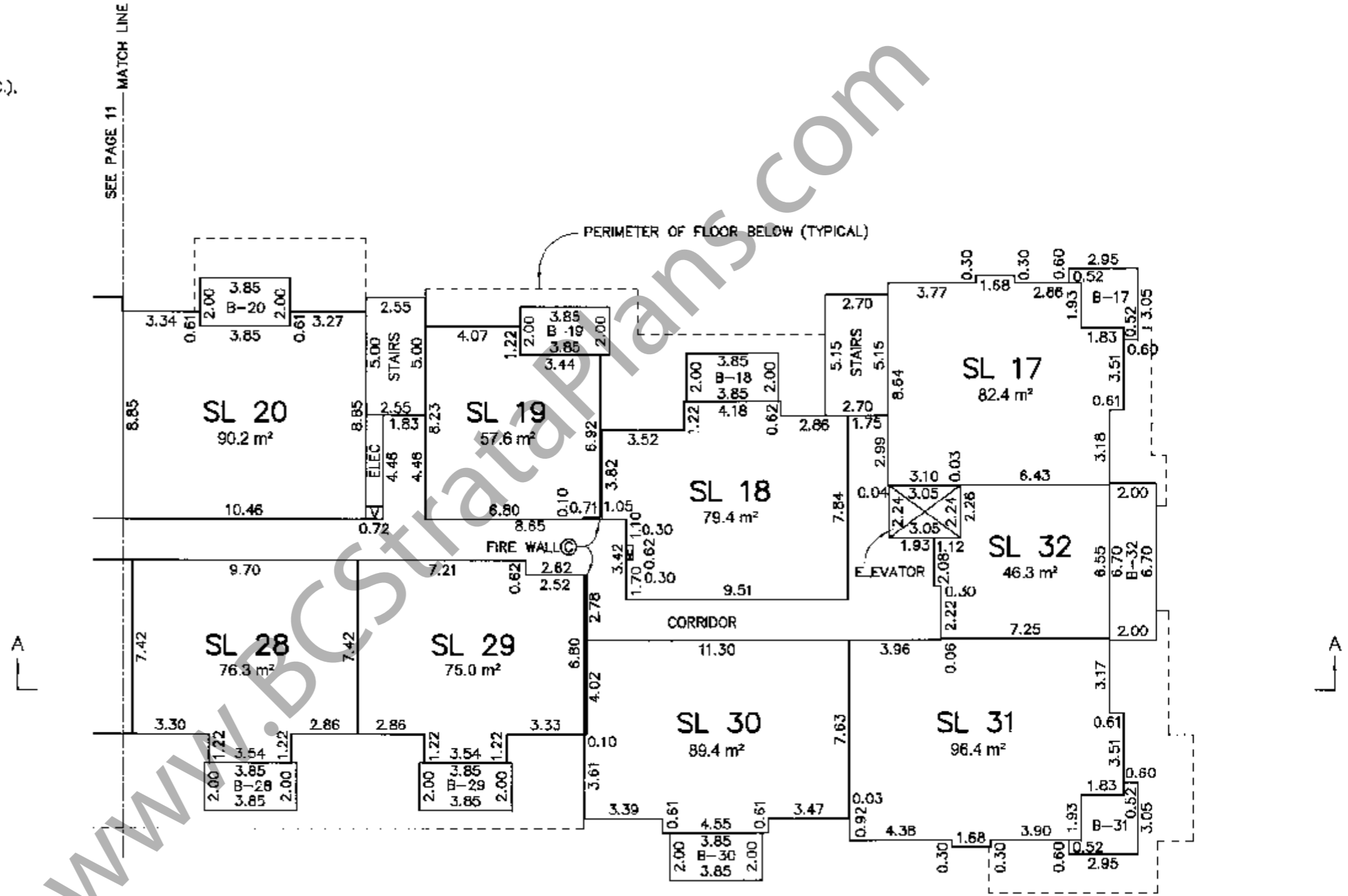

**H.Y. AND ASSOCIATES
LAND SURVEYING LTD.**

200, 9128 - 152nd STREET
SURREY, B.C.

V3R 4E7

(ph) 583-1616

(fx) 583-1737

Job : 052264LS

File: 052264_3_E.DWG

DATE: NOVEMBER 7, 2011

B.C.L.S.

3rd FLOOR (WEST)

STRATA PLAN BCS 4280

SCALE 1:200

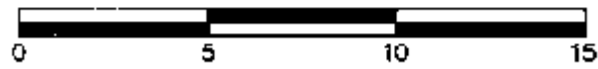

All distances are in metres.

ELEVATOR, CORRIDOR, STAIRS, AND VENT, SHOWN ON THIS PAGE ARE RESIDENTIAL LIMITED COMMON PROPERTIES

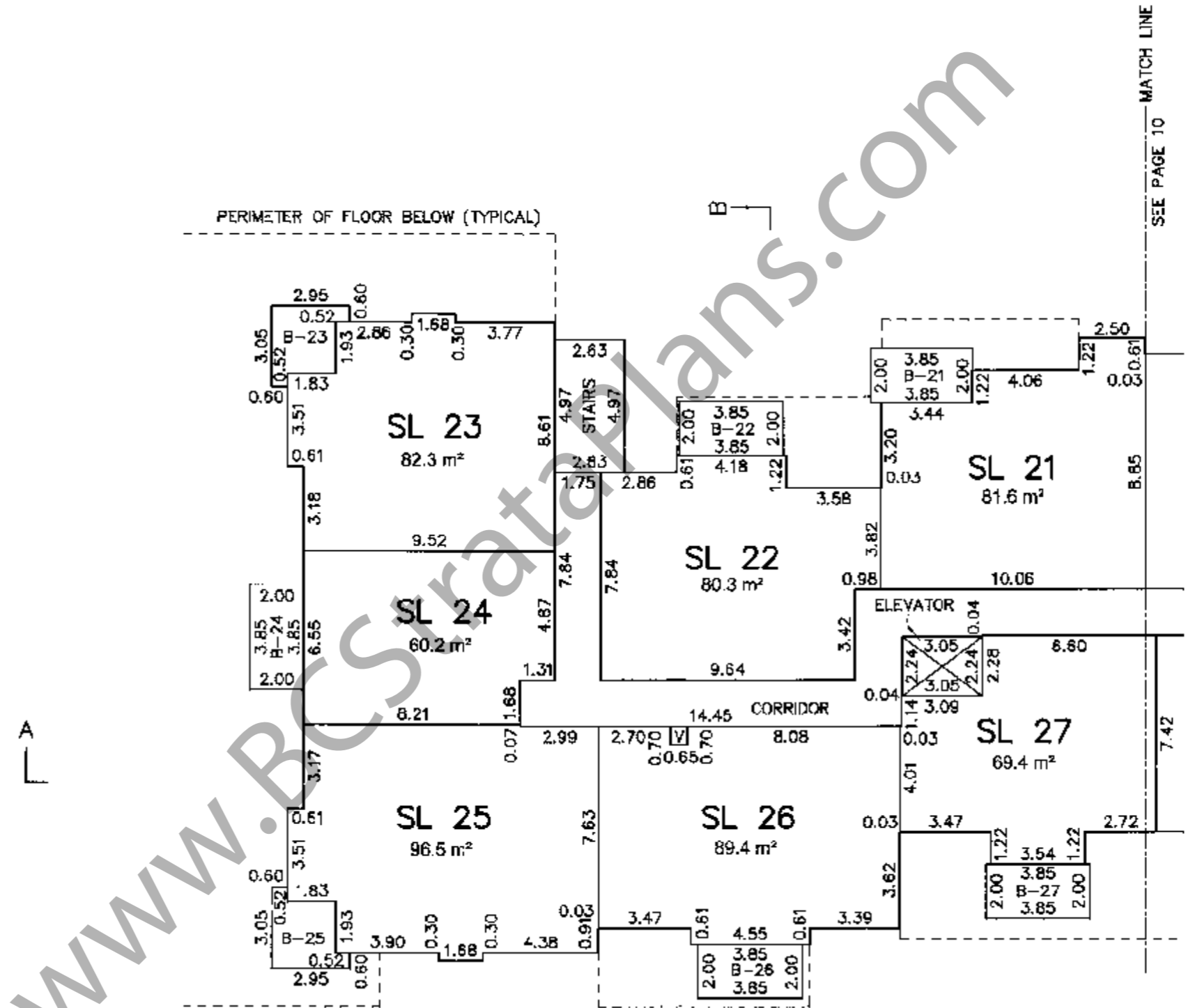

**H.Y. AND ASSOCIATES
LAND SURVEYING LTD.**

200, 9128 - 152nd STREET
SURREY, B.C.

V3R 4E7

(ph) 583-1616

(fx) 583-1737

Job : 052264LS

File: 052264_3_W.DWG

DATE: NOVEMBER 7, 2011

B.C.L.S.

4th FLOOR (EAST)

STRATA PLAN BCS 4280

SCALE 1:200



All distances are in metres.

ELEVATOR, CORRIDOR, STAIRS, ELECTRICAL CLOSET (ELEC.), AND VENT, SHOWN ON THIS PAGE ARE RESIDENTIAL LIMITED COMMON PROPERTIES

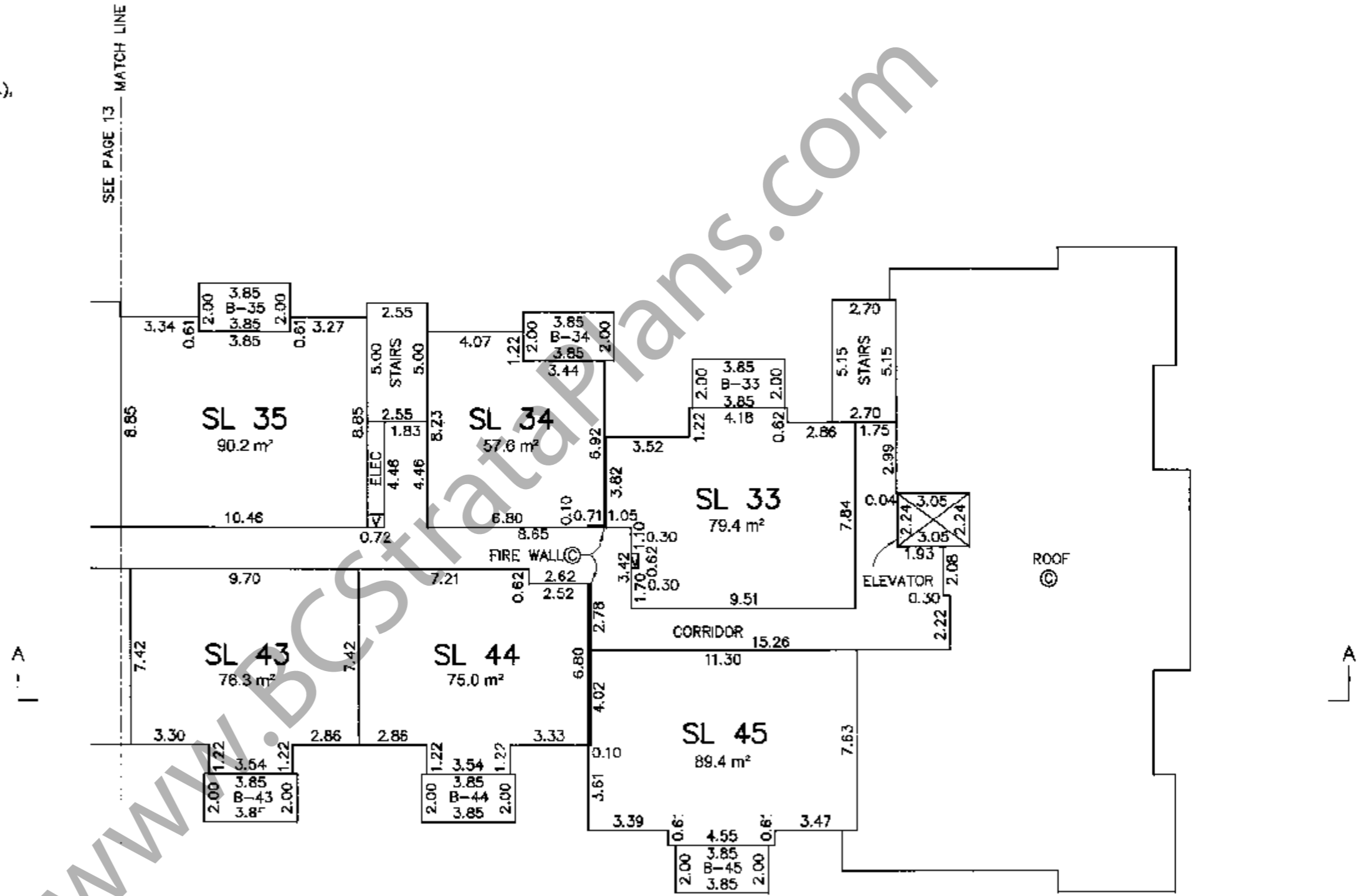

**H.Y. AND ASSOCIATES
LAND SURVEYING LTD.**

200, 9128 - 152nd STREET
SURREY, B.C.

V3R 4E7

(ph) 583-1616

(fx) 583-1737

Job : 052264LS

File: 052264_4_E.DWG

DATE: NOVEMBER 7, 2011

A handwritten signature in black ink.

B.C.L.S.

4th FLOOR (WEST)

STRATA PLAN BCS 4280

SCALE 1:200

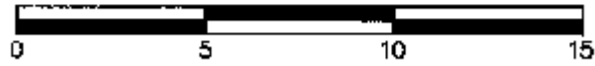

All distances are in metres.

ELEVATOR, CORRIDOR, STAIRS, AND VENT,
SHOWN ON THIS PAGE
ARE RESIDENTIAL LIMITED COMMON PROPERTIES



A

A

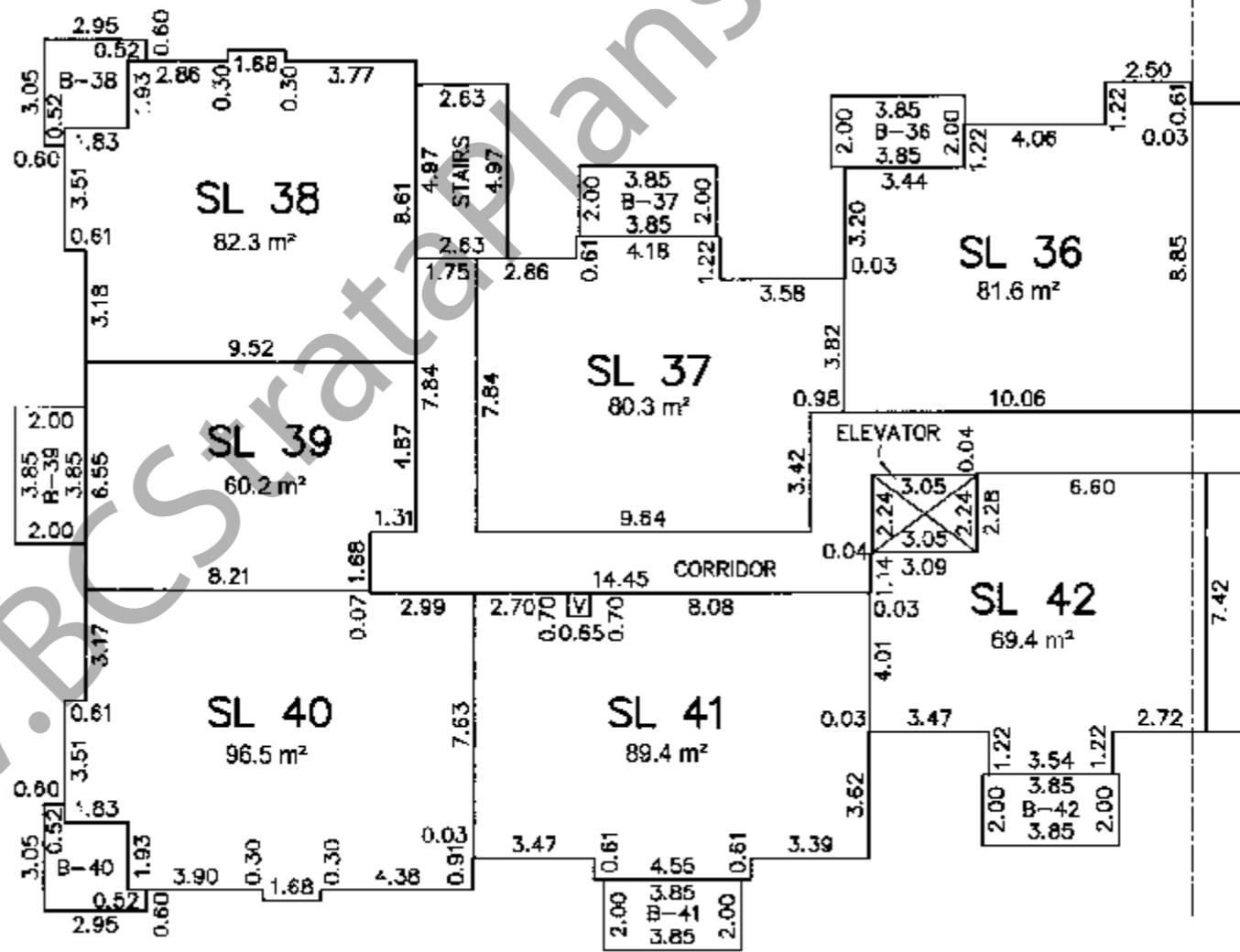

MATCH LINE
SEE PAGE 12

**H.Y. AND ASSOCIATES
LAND SURVEYING LTD.**

200, 9128 - 152nd STREET
SURREY, B.C.

V3R 4E7

(ph) 583-1616

(fx) 583-1737

Job : 052264LS

File: 052264_4_W.DWG

DATE: NOVEMBER 7, 2011

B.C.L.S.

5th FLOOR (EAST)

STRATA PLAN BCS 4380

SCALE 1:200



All distances are in metres.

ELEVATOR, CORRIDOR, STAIRS, ELECTRICAL CLOSET (ELEC.), AND VENT, SHOWN ON THIS PAGE ARE RESIDENTIAL LIMITED COMMON PROPERTIES

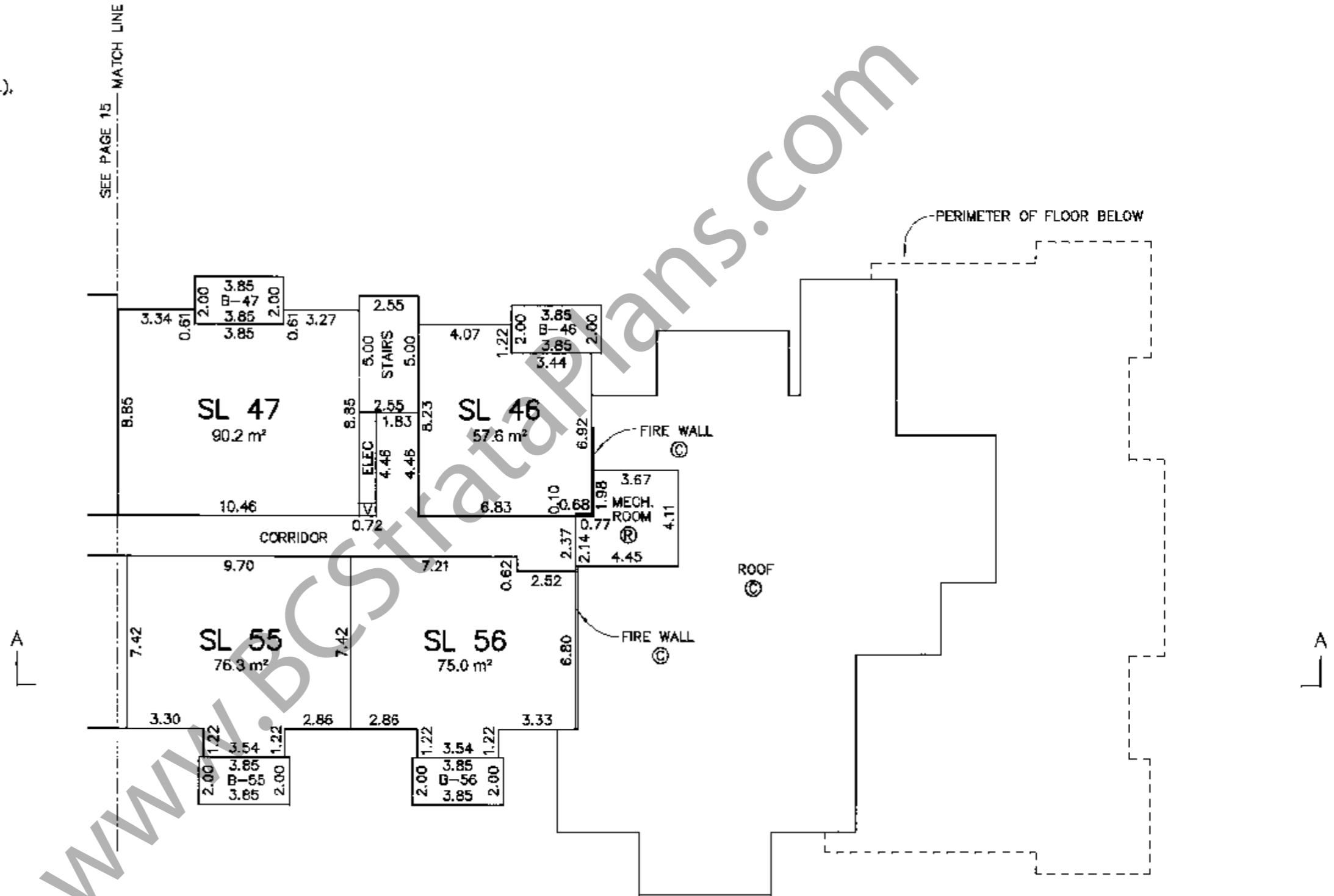

**H.Y. AND ASSOCIATES
LAND SURVEYING LTD.**

200, 9128 - 152nd STREET
SURREY, B.C.

V3R 4E7

(ph) 583-1616

(fx) 583-1737

Job : 052264LS

File: 052264_5_E.DWG

DATE: NOVEMBER 7, 2011

B.C.L.S.

5th FLOOR (WEST)

STRATA PLAN BCS 4280

SCALE 1:200

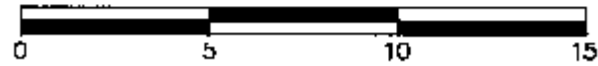

All distances are in metres.

ELEVATOR, CORRIDOR, STAIRS, AND VENT, SHOWN ON THIS PAGE ARE RESIDENTIAL LIMITED COMMON PROPERTIES



A

A

B

MATCH LINE
SEE PAGE 14

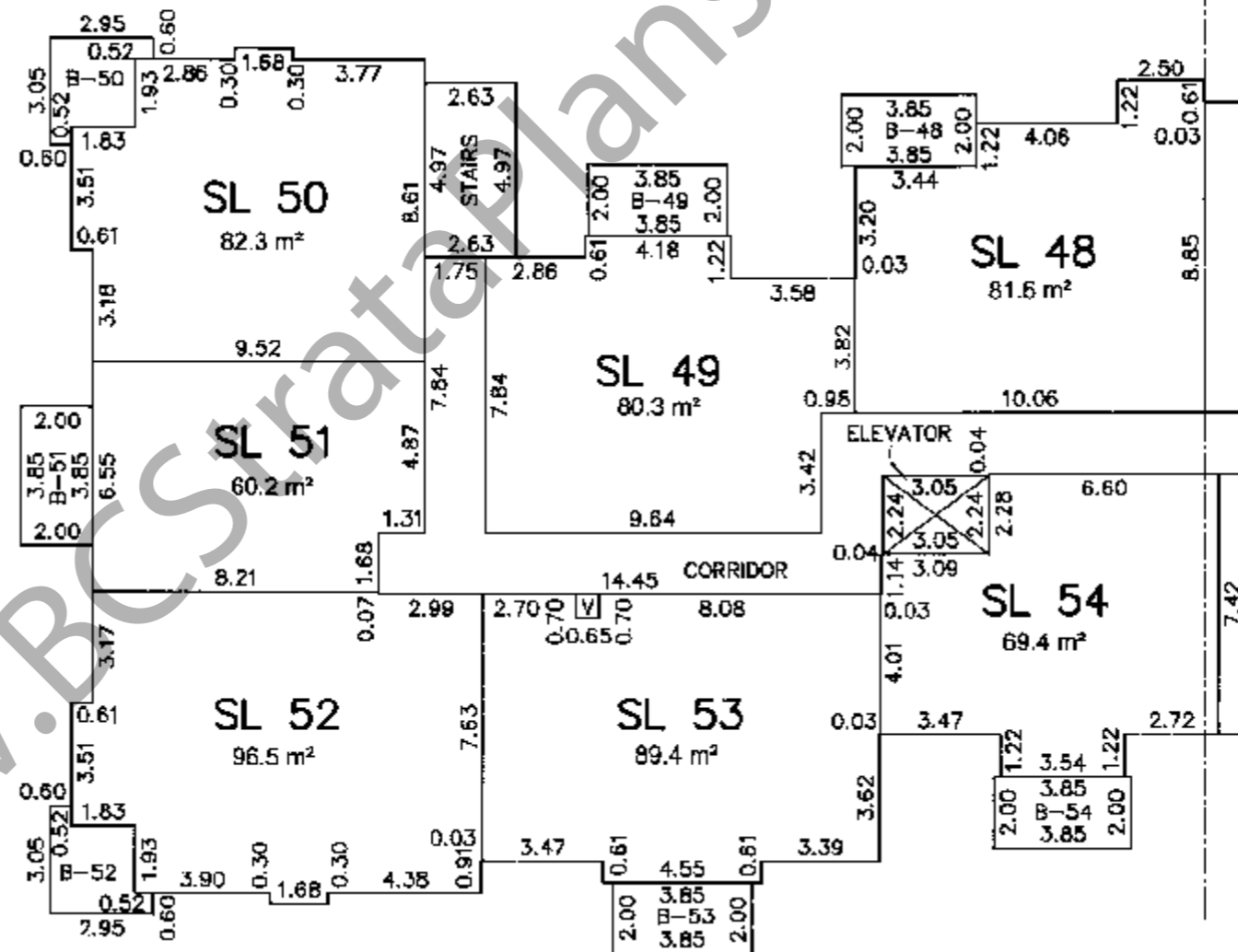

**H.Y. AND ASSOCIATES
LAND SURVEYING LTD.**

200, 9128 - 152nd STREET
SURREY, B.C.

V3R 4E7

(ph) 583-1616

(fx) 583-1737

Job : 052264LS

File: 052264_5_W.DWG

DATE: NOVEMBER 7, 2011

B.C.L.S.

SECTION A

STRATA PLAN BCS 4281

SCALE 1:300

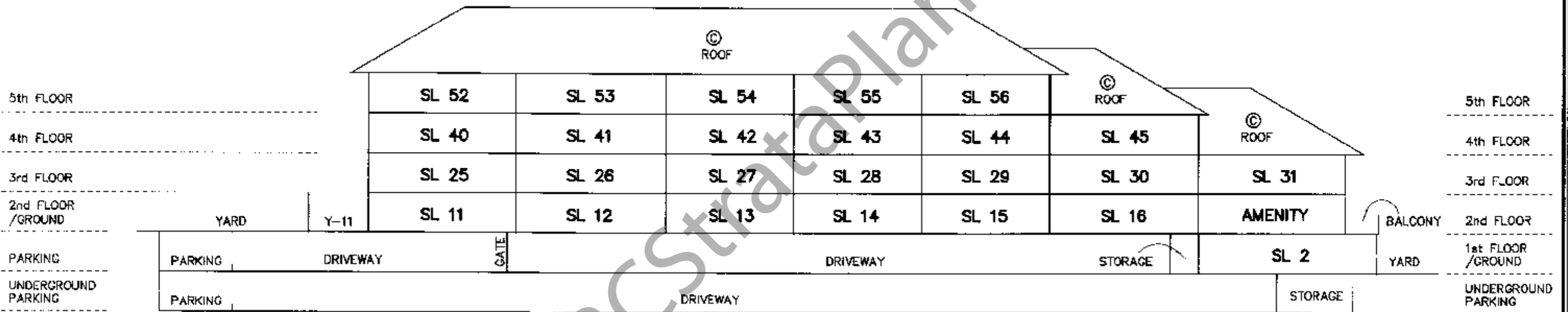
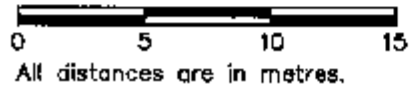

H.Y. AND ASSOCIATES
 LAND SURVEYING LTD.
 200, 9128 - 152nd STREET
 SURREY, B.C.
 V3R 4C7
 (ph) 583-1616
 (fx) 583 1737
 Job : 052264LS
 File: 052264_A.DWG

DATE: NOVEMBER 7, 2011

B.C.L.S.

ORIGINAL

SECTION B

STRATA PLAN BCS 4280

SCALE 1:250

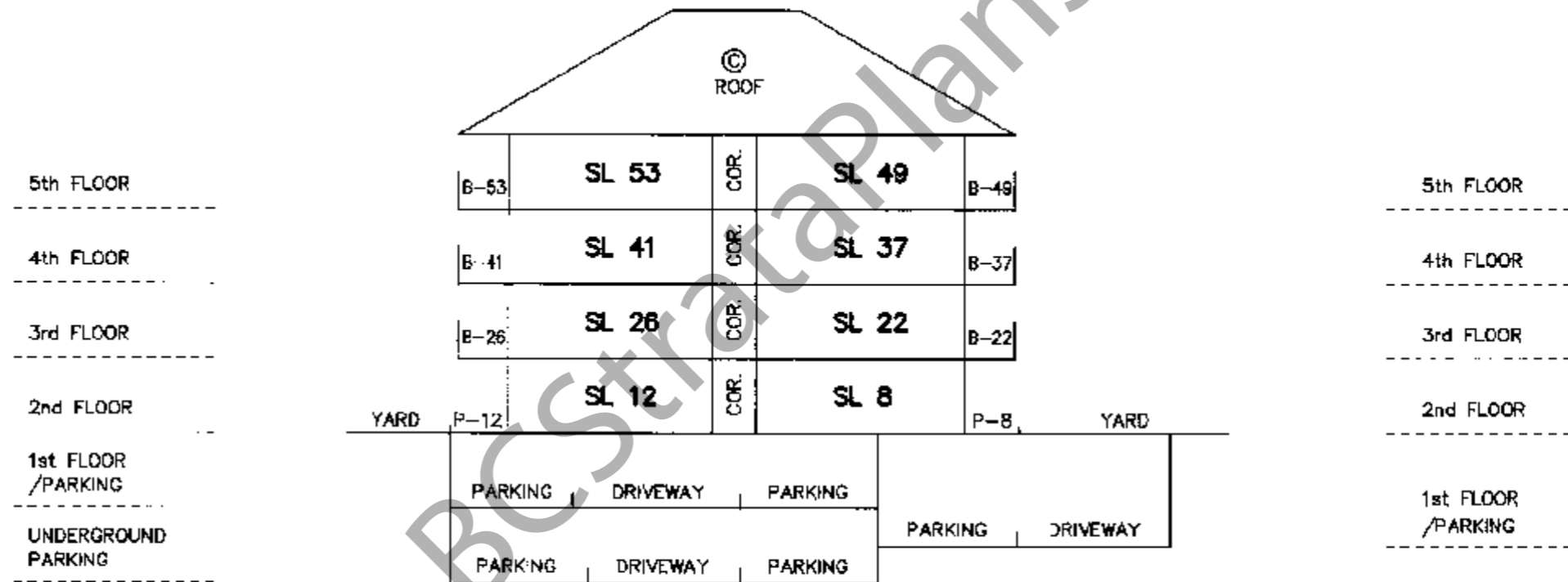
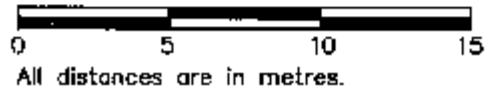

**H.Y. AND ASSOCIATES
LAND SURVEYING LTD.**

200, 9128 - 152nd STREET
SURREY, B.C.

V3R 4E7
(ph) 583-1616
(fx) 583-1737

Job : 052264LS
File: 052264_B.DWG

DATE: NOVEMBER 7, 2011

B.C.L.S.