

Have you been downtown lately?

Lifestyle

Location

Lofts

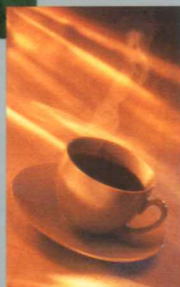

\$88,800

Prices starting from

Own for less than paying rent.

Don't miss the best home ownership opportunity of 1997.

[Lofts Location Lifestyle]

At an incredible price that guarantees this is the *only* place to be.



the | spot

Express yourself - Lo



BCCONDOS.NET





Loft living. If you thought it was just for painters, performers, or artists from the 1960s, take another look. It's now a fully-established and popular alternative for urbanites seeking flexibility in living space and homes with real personality.



The Real Thing

Name a world-class city and look to its commercial or industrial centre and you'll find innovative loft condominiums. New York's SoHo, TriBeCa, and Chelsea districts. Old Los Angeles. Berlin. Milan. Montreal, Vancouver. From the lower eastside to uptown city centre, lofts are being snapped up quickly by young professionals who find the location perfectly suited to busy careers and even busier social calendars. With a loft, there's no end to personal expression. Go minimalist or maximum funk. Stylish metropolitan or contemporary eclectic. With a two-level loft-style condominium, the open floorplans and inspired interior detailing give each owner the opportunity to personalize their living space at a price that typical condominiums can't match. It's the real thing... and it's at The Spot, city centre on Seymour Street.

13ft

n. 1. It's a home. 2. It's an investment. 3. It's an exciting alternative to cookie-cutter condos. 4. It's a way to express your lifestyle at the right time. The right price. The right Spot.



B C C O N D O S . N E T



make your own statement.

The Right Spot

Where are the most exciting changes happening in Vancouver these days? They're right in our own neighbourhood at The Spot. The Ford Centre for the Performing Arts. GM Place. Library Square. And the new stars on Robson Street - Planet Hollywood and Virgin Records. No question about it. The action's on Seymour and Robson... and The Spot is definitely the place to be - an excellent investment now and into the future.



[Downtown Excitement]

What a Way
to Live!

The Spot is not your typical 'cookie cutter' condominium project. It's a downtown home with character - a real New York-style loft with all the exciting features you've been looking for. And no one knows the market better than the builder, Pacific City Land Corp. Together with award-winning architects Kasian Kennedy, they've been behind the creation of The Van Horne and Space downtown, understanding that today's savvy urban consumers want innovation, *but at a reasonable price*. With lofts starting at \$88,800, and incredible amenities just part of the price, The Spot promises to be their next urban triumph.

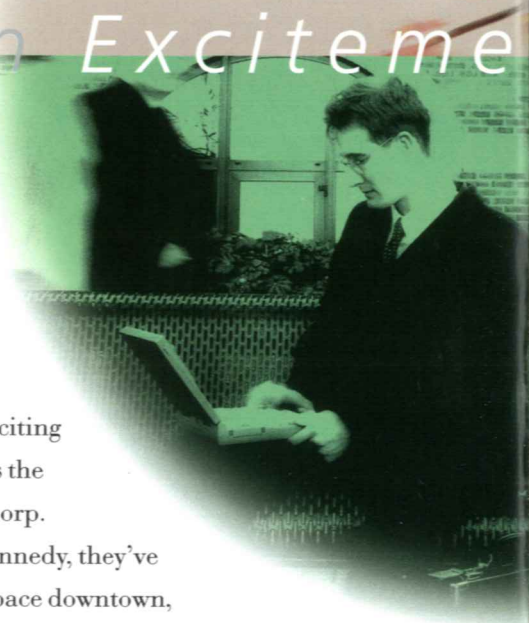

If you're looking for beige carpets or a series of boxy rooms, then The Spot is *definitely* not for you. But if you're interested in making an investment in a living style that's HOT and here to stay, don't miss out on the lofts at The Spot. They won't be around for long.



Hits *The Spot*]

Options? You won't believe the options at The Spot. Go minimalist and completely design your own space. Or choose our option package and move right in. The great thing about loft living is that every loft is as individual as its owner. And the great thing about The Spot is that we make it easy

for you to c



B C C O N D O S . N E T

Now's The Time

It's a green light ahead for purchasers at **The Spot**. Prices start from an incredible \$88,800. Monthly payments as low as \$580 per month... and all lofts under \$189,900! If you don't have a down-payment, we've even got a convenient Spot Savings Plan that allows you to make small monthly payments towards your down-payment so you can buy today. 1997 is definitely the year to say goodbye to your landlord forever!



Loft living offers lots of opportunity for freedom of expression. Beautifully finished space with great views, great light, and incredible finishing details – who could ask for a better spot for a downtown investment?

Own for as little as
\$580.00
per month!



The Inside Story

"Once the trendy territory of pioneering artists, lofts have gone mainstream. No longer rough-and-ready industrial spaces, lofts now come with all the amenities and feel like home."

Diane Dorrans Sacks, *The San Francisco Chronicle*, July 21, 1993

The Spot. Nowhere in Vancouver have price and quality come together as perfectly. Solid concrete and steel construction in a modern expressionist tower. Dramatic living spaces with full-width sleeping lofts. Double-height windows. Natural floors. Ebony or beechwood cabinets.



Loft of Roger Kaadoo, Designer

Building amenities include a landscaped roof garden, BBQ terrace, bicycle workshop and storage, fitness lounge, and Rogers WAVE™ Internet access and Business Centre space to hook up your laptop.

Now you'll understand why The Spot will

LOOK UP

Take a look at the downtown Vancouver residential scene and you'll know things are definitely looking up – way UP – with the introduction of The Spot, Vancouver's first *all-loft, all-affordable, hi-rise* tower. From London to Milan, San Francisco to Paris, the market has never been hotter for loft living. This is your exclusive opportunity to get in on the ground floor of Vancouver's *best* planned, *best* positioned, and *best* priced new loft condominium project.



[Priced from \$88,800 **the | spot** with all lofts under \$189,900!]

In fact, quality and price have never come together like this before in Vancouver. No wonder the interest is sky-high for those who want to be in on this once-in-a-city opportunity to own a two-level, New York-style loft home right in the heart of the entertainment and business centre of Vancouver. Live in. Rent out. Or keep The Spot as your downtown 'occasional' address. At starting prices from \$88,800, the lowest interest rates in 40 years, and no competition when it comes to value, now's the time to hit The Spot.



BC CONDOS.NET



Today... before it's too late.

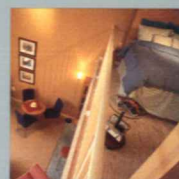

the | spot

Vancouver's Only All-Loft Hi-Rise Residences

priced from just

\$88,800



The Spot is destined to become one of Vancouver's most sought-after residences. Incredible value. Fantastic floorplans. An opportunity to express how you live. Plus a location that lets you work and play in the heart of the city.

Public Grand Opening

Saturday, March 15th at
12 noon. Presentation Centre
at 933 Seymour Street
(between Nelson & Smith)
Vancouver, British Columbia.
e-mail: spot@mindlink.bc.ca

CALL 684-LOFT
For Your Exclusive
Loft Lifestyle Discovery Kit

- | | |
|---------------------------------------|---|
| 1 The Spot | 8 Robson Street Shopping District |
| 2 Theatre Row | 9 Pacific Centre |
| 3 Ford Centre for the Performing Arts | 10 Queen Elizabeth Theatre |
| 4 Library Square | 11 BC Place Stadium |
| 5 GM Place | 12 SkyTrain Station |
| 6 Yaletown | 13 Seawall access to Granville Island Ferry |
| 7 Vogue | 14 Orpheum Theatre |



M · I · L · B · O · R · N · E

To maintain the high

Payments based on a three-year term, 0% down, and 1/2% per month.

B C C O N D O S . N E T

lications, and features.

time of printing.

ARCHITECTURAL CONCEPT AND
DISCUSSION PAPERS FOR:

THE SPOT DEVELOPMENT 1997

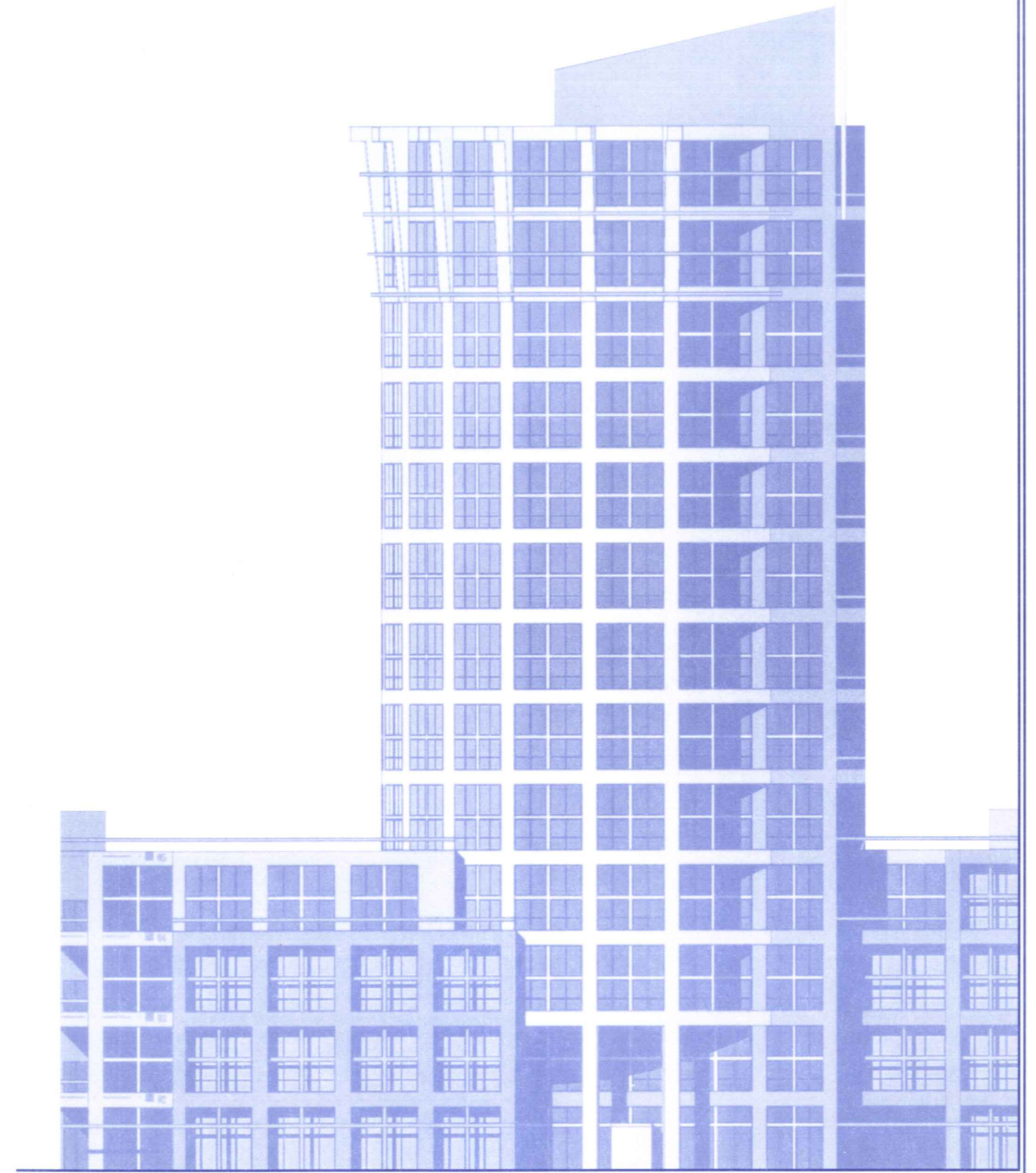

DEVELOPMENT TEAM	
DEVELOPER	PACIFIC CITY LAND CORPORATION
ARCHITECT	KASIAN KENNEDY DESIGN PARTNERSHIP
DESIGNER	FALSE CREEK DESIGN
MARKETING & SALES	MILBORNE REAL ESTATE CORPORATION

THE SPOT	PAGE 1
PLANS PREPARED FOR:	 the spot



BCCONDOS.NET



Draft Copy for the Spot: These drawings are taken from preliminary discussions at the early stage of design and may be subject to change without notice. E. & O.E.

THE SPOT -

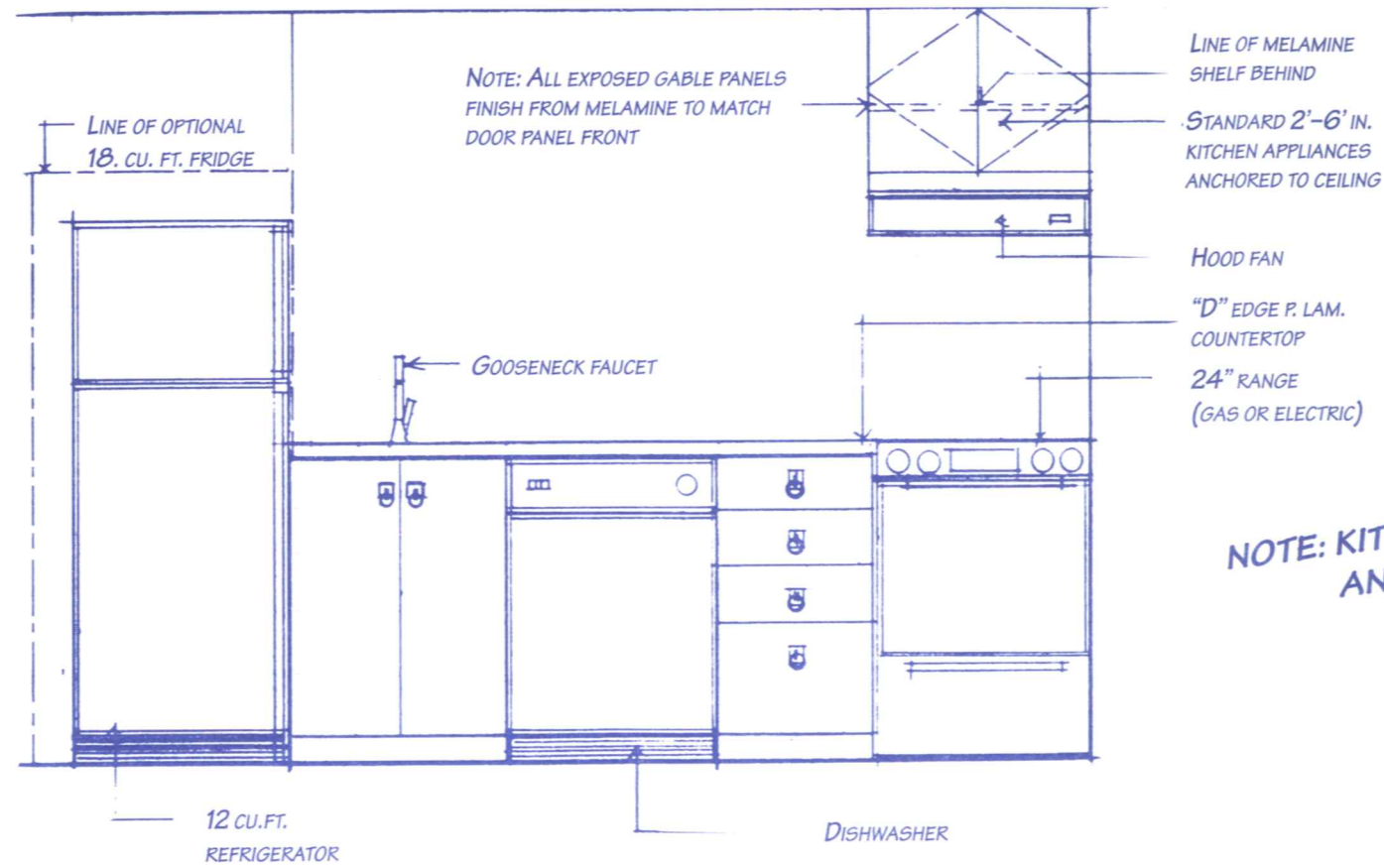

NOTE: KITCHEN POSITIONED FOR OPEN AND BRIGHT FEELING

CUSTOM DESIGN KITCHEN

- Maximum counter space and entertainment layout -

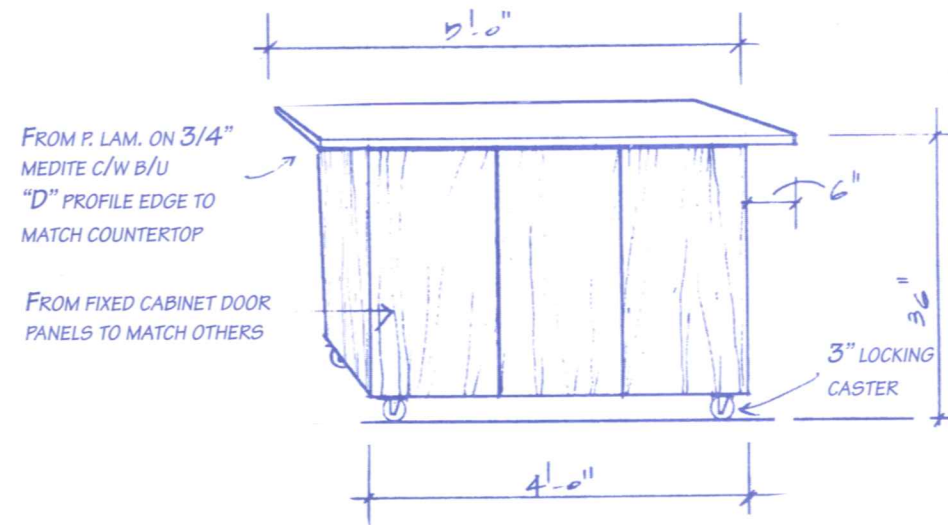

CONVENIENT ROLLING ISLAND

- Custom-designed to provide storage space -



THE SPOT - SITE CONTEXT AND NEIGHBOURHOOD ANALYSIS

**LOCATION, LOCATION, LOCATION:
IT'S ALL IN THE CENTRE OF THE CITY**

- LIVE, WORK AND PLAY IN CANADA'S NUMBER-ONE CITY, VANCOUVER
- IN THE HEART OF DOWNTOWN
- STEPS TO YALETOWN
- NEXT TO THEATRE ROW
- TWO BLOCKS TO THE NEW ENTERTAINMENT DISTRICT: THE FORD THEATRE, GM PLACE, AND LIBRARY SQUARE
- CLOSE TO SHOPPING, RESTAURANTS, AND FINANCIAL DISTRICT
- ROLLERBLADE TO THE SEA WALL
- WALK TO WORK

LEGEND OF KEY LOCATIONS

- 1 THE SPOT
- 2 VOGUE THEATRE
- 3 THEATRE ROW
- 4 ORPHEUM THEATRE
- 5 ROBSON STREET SHOPPING DISTRICT
- 6 PACIFIC CENTRE
- 7 FORD CENTRE FOR THE PERFORMING ARTS
- 8 LIBRARY SQUARE
- 9 YALETOWN
- 10 QUEEN ELIZABETH THEATRE
- 11 SKYTRAIN STATION
- 12 GM PLACE
- 13 BC PLACE STADIUM
- 14 SEAWALL ACCESS TO GRANVILLE ISLAND FERRY



THE SPOT	PAGE 3
AREA ANALYSIS NOTES	 the spot



THE SPOT - FEATURES & AMENITIES

At First Glance

- At the centre of Downtown Vancouver and the new entertainment district
- Modern Expressionist tower
- A new Downtown landmark
- Dramatic views of English Bay and Downtown
- Double-height lobby with glass entry

Amenities

- On-site resident manager
- Landscaped 2nd floor deck complete with BBQ & gathering area
- 5th floor landscaped terrace
- Residents' lounge area with fully equipped kitchen opening onto terrace
- Business Centre & Meeting Room
- Equipped fitness studio overlooking landscaped terrace
- Handyman area with work bench
- Bicycle storage
- Rooftop observation deck
- Gated underground parking
- Two high-speed elevators

Creative Living Space

- Two urban-inspired colour schemes
- Solid-core birch veneer entry doors
- Chrome hardware deadbolt and custom escutcheon plate
- Natural concrete floors
- Decora light switches
- Painted wood baseboards
- Double-height living areas
- 14' double-glazed windows with opening sections
- Custom-designed, open-tread stairs with aluminum and plexi railings
- Dramatic loft spaces with full-width overlooks

Designer Kitchen

- Ebony or beechwood laminate cabinets
- High-pressure matte finish laminate countertops
- Open pantry shelving
- Polished chrome gooseneck faucet
- Stainless steel kitchen sink
- 1/3 h.p. waste disposal
- Halogen track lighting
- Ebony gas stove by GE
- Ebony energy-efficient dishwasher by GE
- Ebony refrigerator by GE

Bathrooms

- 5-foot acrylic soaker tub by Jacuzzi
- Oval stainless steel sink
- Oval low-flush toilet by Kohler
- European-style polished chrome faucets by Euromix
- White or beechwood laminate cabinets
- Hand-set ceramic tile tub surround with architectural pattern
- Ceramic tile flooring
- Full-width vanity mirror
- Custom-designed vanity light fixture
- Chrome-finished towel rack
- Distinct bathroom accessories

Energy Efficiency and Soundproofing

- All suites and common areas are fully sprinklered
- Energy-efficient lighting in all common areas
- Solid concrete and steel construction
- Superior party wall construction
- Double-glazed thermally broken windows
- Rough-in for stacking washer and dryer
- Rough-in for ceiling fan

Security

- Card access to lobby, parkade and elevator vestibule
- Underground parking entrance with infra-red device
- 24-hour camera surveillance of entrances, parkade, bike storage and amenity deck
- Video enterphone

Proposed Spot Card Privileges

- \$500 Ikea decorating certificate
- Rogers Wave Installation
- A loft book to help you get creative with your new loft residence
- Downtown entertainment pack
- Free legal package
- 1/2% off current mortgage rates

THE SPOT

PAGE 4

PROPOSED FINISHING
SPECIFICATIONS



the | spot



BCCNCONDOS.NET



Soft Copy for the Spot: These drawings are taken from preliminary discussions at the early stage of design and may be subject to change without notice. E. & O.E.

April 6, 1997

Province

SUNDAY Homes

C1

Live the loft life



This Spot's for you

By Judy Swanson
Sunday Homes Reporter

Personalizing your space from a menu of upgrade options is a pretty common selling tool these days in the fiercely competitive condo marketplace.

Will you have maple or white cabinetry, hardwood floor or carpeting?

The Spot, Pacific City Land Corp.'s new 26-storey tower soon to rise on Seymour Street between



OPEN HOUSE

Smythe and Nelson goes one step farther.

At The Spot, Vancouver's first all-loft highrise, you can decide whether you even want floors.

Actually that might be slightly overstating it.

Each unit comes with floors but whether you cover them at all is your call.

"What we deliver is a constructed two-level loft with unfinished concrete floors with a kitchen and bathroom. It's unfinished in terms of decoration," said Pacific City's Howard Raphael.

Raphael said many of the first-time buyers in the building are choosing to forego traditional floor coverings in favor of acid-washing the concrete with a resulting shiny finish he described as "quite pretty."

Please turn to page C2

At the Seymour Street presentation centre for The Spot, Vancouver's first all-loft highrise, there are two display suites: One, shown above, is the bare-bones basic unit. The other, at right, is embellished with carpet, hardwood flooring and furnishings.



Staff photos by David Clark

MIX AND MATCH TO DESIGN YOUR OWN DOWNTOWN SPACE



BCCONDOS.NET





Open-tread stairs with aluminum and glass railings lead to the loft bedroom.

Staff photo by David Clark

Jacuzzi is standard issue

Continued from page C1

The 187-unit tower will be arranged in 13 floors of two-level lofts which range in size from 550 to 750 sq. ft.

Under 800 sq. ft. may sound small but the upper bedroom loft covers only part of the lower level so the resulting vaulted ceiling and 14-foot windows give a very airy open feeling to the space.

There are two display models at the presentation centre on Seymour.

One is the bare-bones basic unit. The other is embellished with carpet, hardwood flooring and furnishings.

Kitchens at The Spot offer a choice between ebony or beechwood laminate lower cabinets.

The upper cabinet unit is an upgrade.

The single stainless steel sink has a garburetor and is very handsomely appointed with a polished chrome gooseneck faucet.

The fridge, stove and dishwasher are black and buyers can choose between electric or gas range.

Open pantry shelving and a moveable island counter complete each kitchen.

The moveable island is a nice feature offering storage, meal-prep space and breakfast bar in one.

Depending on your entertaining tastes the

island could eliminate the need for a dining table with an added bonus: It can be pushed off to one side when it's not being used.

Each unit has one bathroom which can be dressed in either a beechwood and blue or black-and-white color scheme.

An oval stainless steel sink adds decorating interest and the five-foot Jacuzzi soaker tub is standard issue.

Open-tread stairs with aluminum and glass railings lead to the loft bedroom.

There also is a storage space upstairs that can be outfitted in a stackable washer and dryer but the building also will offer common laundry facilities so a small home office could

be tucked nicely into this space.

Each unit comes with pot lights, halogen cable lighting and a ceiling fan.

The complex will be anchored with retail space at street level.

The building is divided into two sections — a seven-storey podium with a glass tower rising from its centre.

Residents will be able to enjoy an elevated landscaped terrace as well as a roof-top observatory.

Other building amenities include a fitness studio overlooking the terrace and a business centre.

Prices at The Spot start at \$88,800 and run to \$189,900 — hard to beat for a penthouse in the downtown entertainment district.

Vaulted ceiling, 14-foot windows give airy feeling



[Features & Amenities]

At First Glance

- At the centre of Downtown Vancouver and the new entertainment district
- Modern Expressionist tower
- A new Downtown landmark
- Dramatic views of False Creek and Downtown
- Double-height lobby with glass entry

Amenities

- On-site resident manager
- Landscaped deck complete with BBQ & gathering area
- 5th floor landscaped terrace
- Residents' lounge area with fully equipped kitchen
- Business Centre & Meeting Room
- Equipped fitness studio overlooking landscaped terrace
- Handyman area with workbench
- Bicycle storage
- Rooftop observation deck
- Two high-speed elevators

Creative Living Space

- Two urban-inspired colour schemes
- Solid-core birch veneer entry doors
- Chrome hardware deadbolt and custom escutcheon plate
- Natural concrete floors

- Decora light switches
- Painted wood baseboards
- Double-height living areas
- 14' double-glazed windows with opening sections
- Custom-designed, open-tread stairs with aluminum and glass railings
- Dramatic loft spaces with overlooks
- Halogen cable lighting

Designer Kitchens

- Ebony or beechwood laminate cabinets
- High-pressure matte finish laminate countertops
- Open pantry shelving
- Polished chrome gooseneck faucet
- Stainless steel kitchen sink
- 1/3 h.p. waste disposal
- Black gas stove
- Black energy-efficient dishwasher
- Black refrigerator

Bathrooms

- 5' acrylic soaker tub by Jacuzzi
- Oval stainless steel sink
- Oval low-flush toilet by Kohler
- Euromix polished chrome faucets
- White or beechwood laminate cabinets

- Ceramic tile flooring
- Full-width vanity mirror
- Custom-designed vanity light fixture
- Chrome-finished towel rack and bathroom accessories

Energy Efficiency and Soundproofing

- All suites and common areas are fully sprinklered
- Energy-efficient lighting in all common areas
- Solid concrete and steel construction
- Superior party wall construction
- Double-glazed windows
- Rough-in for stacking washer and dryer

Security

- Card access to lobby, parkade and elevator vestibule
- 24-hour camera surveillance of entrances, parkade, bike storage, and amenity deck
- Video enterphone
- Gated underground parking



the | spot



B C C O N D O S . N E T



To maintain the high standard of this project, the builder reserves the right to modify plans, specifications, and features. Correct at time of printing.

Pacific City Land Corp

Capturing the style of a city

Today more than ever before, people are looking for homes with a distinct personality; living spaces that reflect both their lifestyles and their ambitions. In Vancouver, few builders have been as successful at meeting the needs of the urban homeowner as Pacific City Land Corp.

Artech. Space. The Van Horne. Carrall Station. Memorable residential projects that capture the style of a vibrant city.

Now ... The Spot. Real lofts without sacrificing the amenities of a modern building. From the team at Pacific City Land Corp who first introduced the unique loft lifestyle to downtown Vancouver.



An incredible modern expressionist building

Vancouver's only place to be!

The Spot is destined to become one of





Vancouver's most sought-after residences.

Incredible value. Fantastic floorplans.

An opportunity to express how you live.

Plus a location that lets you work and play in the heart of the city.



-  Yaletown
-  English Bay
-  Entertainment District
-  Robson Street Shopping

- 1 The Spot
- 2 Vogue Theatre
- 3 Theatre Row
- 4 Orpheum Theatre
- 5 Robson Street Shopping
- 6 Pacific Centre
- 7 Ford Centre for the Perfo
- 8 Library Square
- 9 Yaletown
- 10 Queen Elizabeth Theatre
- 11 SkyTrain Station
- 12 GM Place
- 13 BC Place Stadium

CALL 684-LOFT

e-mail: spot@mindlink.bc.ca



BCCONDOS.NET



NEW HOME WARRANTY

MILBORNE