

STRATA PLAN OF PART OF LOT 2
SECTION 14 TOWNSHIP 39
NEW WESTMINSTER DISTRICT PLAN BCP481
CITY OF COQUITLAM

STRATA PLAN BCS 790
PHASE 1

B.C.G.S. 92G.027

DEPOSITED AND REGISTERED IN THE LAND
TITLE OFFICE AT NEW WESTMINSTER B.C.
May 3 2004

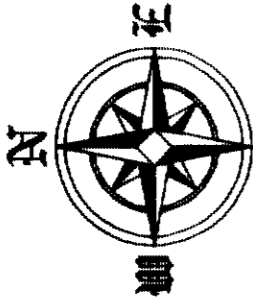
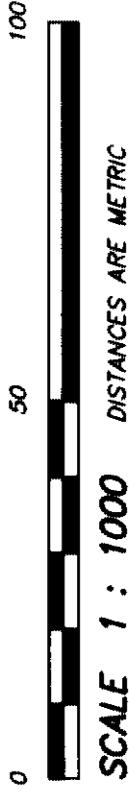

B. Bignardos
DEPUTY REGISTRAR

BW183694 - DW 183733
FORM P - DW 183693

PLAN BCP473

INTEGRATED SURVEY AREA NO. 14 (COQUITLAM)
NAD83(CSRS)

THIS PLAN SHOWS HORIZONTAL GROUND-LEVEL DISTANCES EXCEPT
WHERE OTHERWISE NOTED TO COMPUTE GRID DISTANCES. MULTIPLY
GROUND-LEVEL DISTANCES BY COMBINED FACTOR, 0.99995910

CIVIC ADDRESS:
2978 WHISPER WAY
COQUITLAM, B.C.

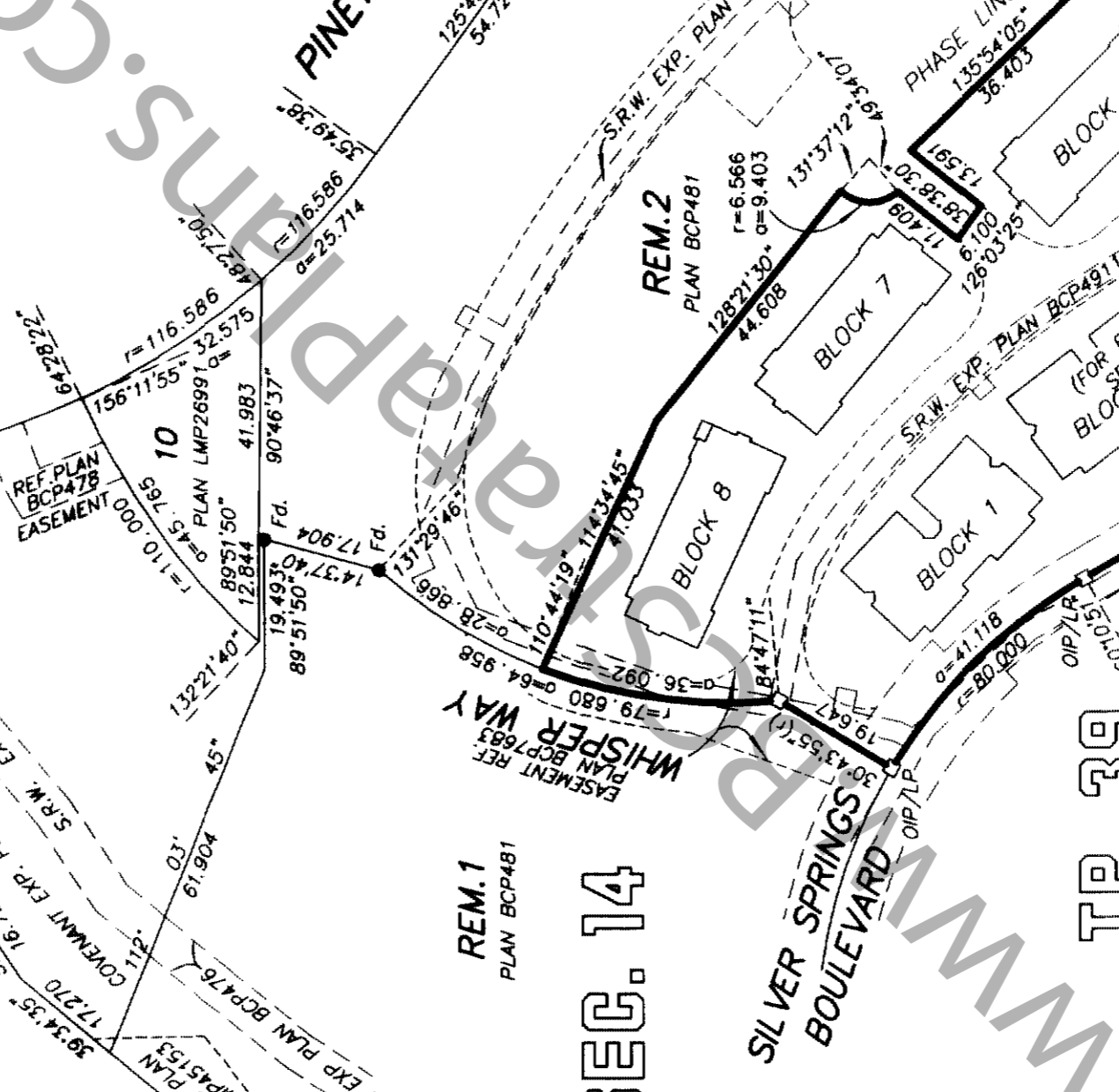

REM.1
PLAN BCP481

SEC. 14

SILVER SPRINGS
BOULEVARD

PINETREE WAY

WHISPER WAY

TP. 39

BCS541
PHASE 1
PLAN BCP481

I, GARY SUNDVICK, A BRITISH COLUMBIA LAND SURVEYOR,
OF LANGLEY, BRITISH COLUMBIA, CERTIFY THAT I WAS
PRESENT AT AND PERSONALLY SUPERINTENDED THE SURVEY
REPRESENTED BY THIS PLAN, AND THAT THE SURVEY AND
PLAN ARE CORRECT. THE FIELD SURVEY WAS COMPLETED ON
THE 26th DAY OF FEBRUARY, 2004. THE PLAN WAS COMPLETED
AND CHECKED, AND THE CHECKLIST FILED UNDER #12270
ON THE 2nd DAY OF MARCH, 2004.

B.C.L.S.

THIS PLAN LIES WITHIN THE GREATER VANCOUVER REGIONAL DISTRICT

DYCK & ASSOCIATES
PROFESSIONAL LAND SURVEYORS
#4 - 19089 94th AVENUE
SURREY, B.C. V4N 3S4
TEL: 513-9611 FAX: 513-2202
FILE : 2935
DWG : 2935-S10

STRATA PLAN BCS 790 PHASE 1

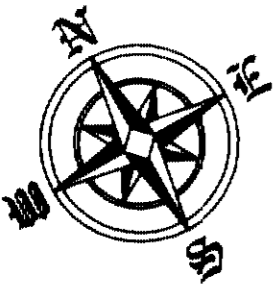

SCALE 1 : 400 DISTANCES ARE METRIC

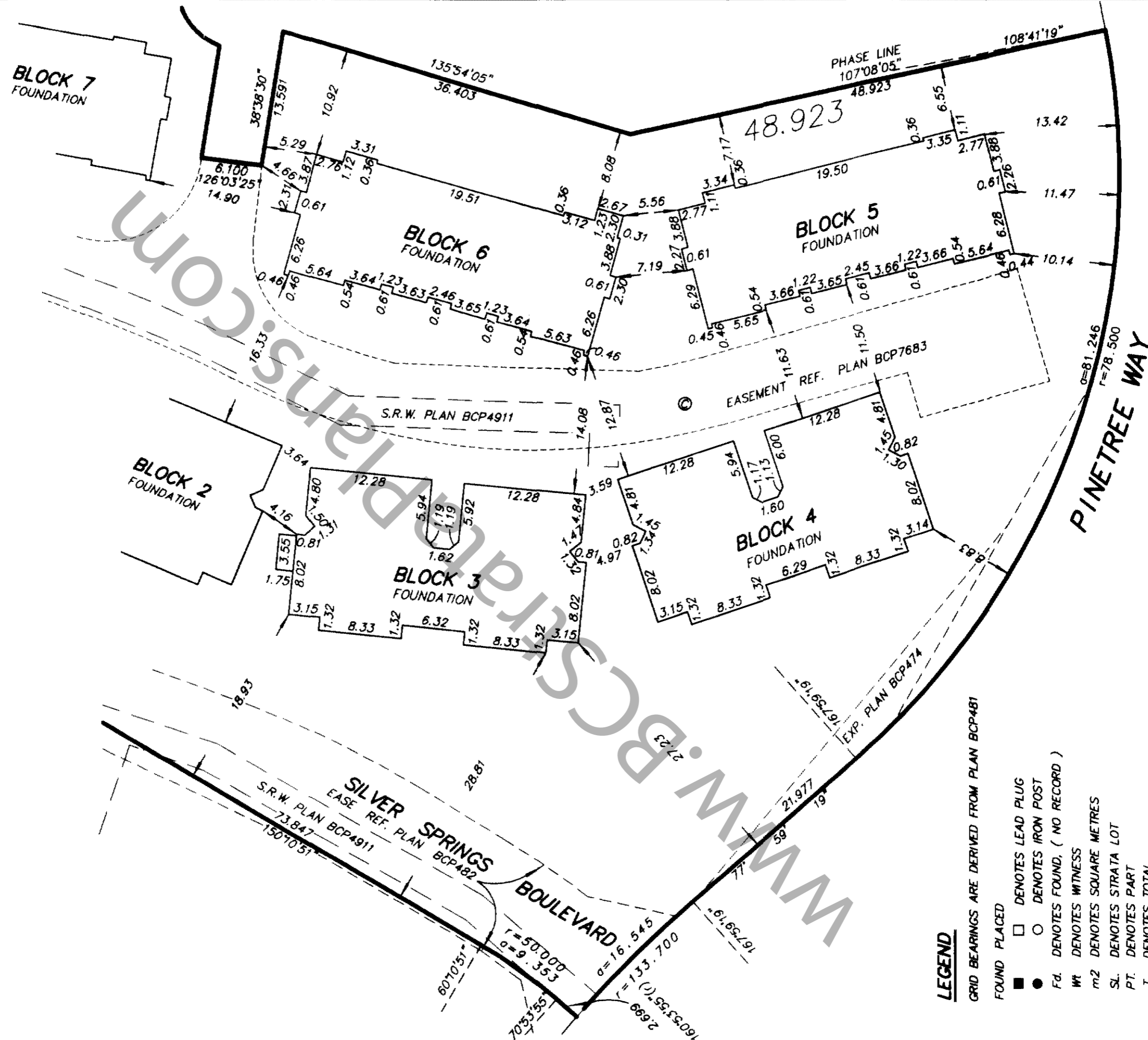

LEGEND

- GRID BEARINGS ARE DERIVED FROM PLAN BCP481
- FOUND PLACED
- DENOTES LEAD PLUG
 - DENOTES IRON POST
 - Fd. DENOTES FOUND, (NO RECORD)
 - Wt DENOTES WITNESS
 - m2 DENOTES SQUARE METRES
 - SL. DENOTES STRATA LOT
 - PT. DENOTES PART
 - T DENOTES TOTAL
 - ⊙ DENOTES COMMON PROPERTY
 - Ⓢ DENOTES DECK BEING LIMITED COMMON PROPERTY FOR EXCLUSIVE USE OF ADJOINING STRATA LOT
 - Ⓣ DENOTES ELECTRICAL ROOM BEING COMMON PROPERTY
 - Ⓟ DENOTES PATIO BEING LIMITED COMMON PROPERTY FOR EXCLUSIVE USE OF ADJOINING STRATA LOT
 - Ⓠ (L.C.P.-28) DENOTES L.C.P. BEING LIMITED COMMON PROPERTY FOR EXCLUSIVE USE OF STRATA LOT 28 (TYPICAL)

FEBRUARY 27, 2004
FILE: 2935-511

SHEET 3 OF 12 SHEETS

STRATA PLAN BCS 790
PHASE 1



SCALE 1 : 400 DISTANCES ARE METRIC

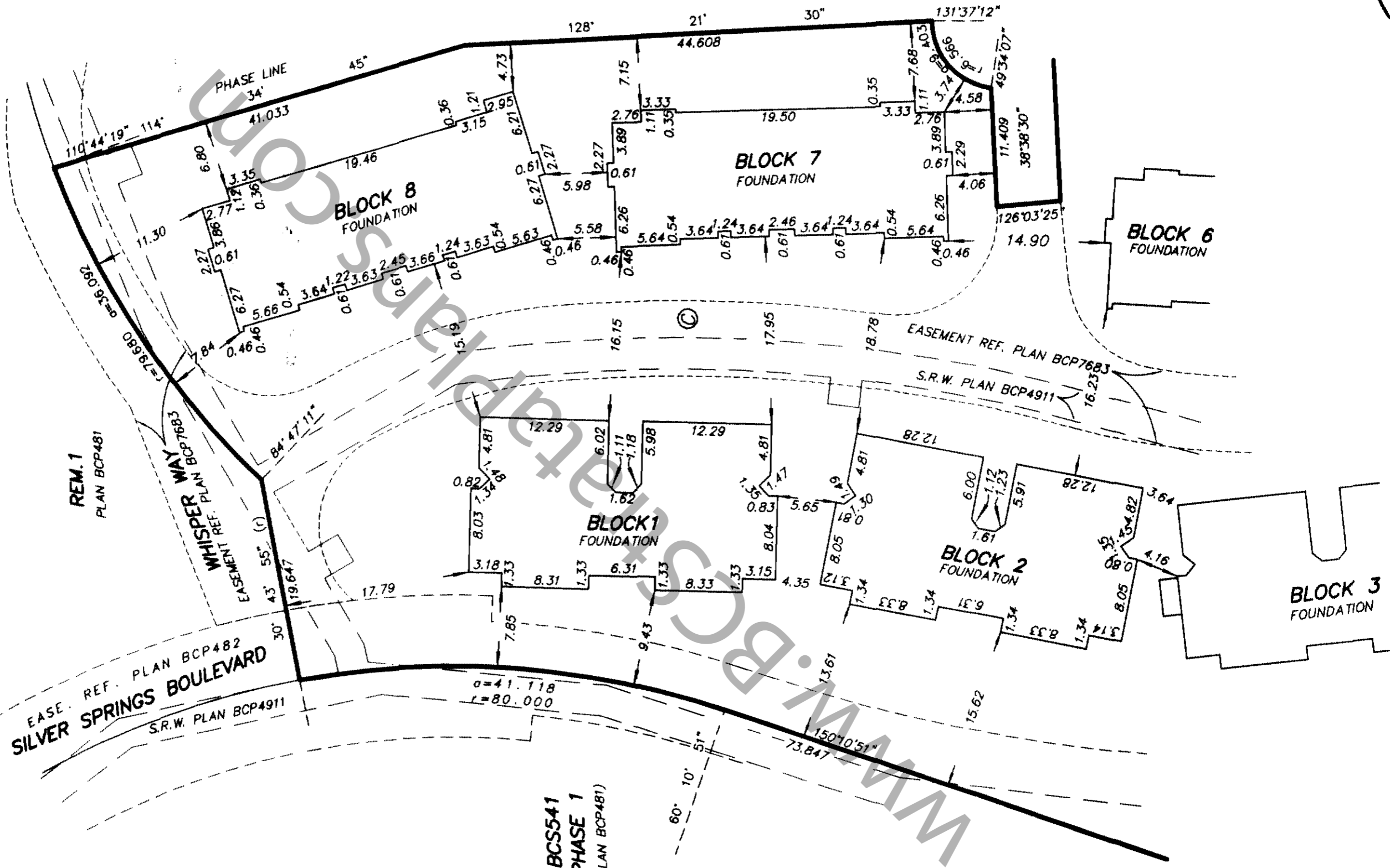

BCS541
PHASE 1
(PLAN BCP481)

FEBRUARY 26, 2004
DWC : 2935-S12

STRATA PLAN BCS 790
PHASE 1

STRATA PROPERTY ACT

OWNER:
POLYGON SILVER SPRINGS DEVELOPMENT LTD.
(INCORPORATION No. 493367)

MORTGAGEE:
THE BANK OF NOVA SCOTIA

Name: NEIL CRYSTAL
Authorized Signatory

Name: PATRICK BAENMAN
Authorized Signatory

Name: RALE SCHMIDTKE
Authorized Signatory

Name: MICHAEL DOWNING
Authorized Signatory

WITNESS AS TO BOTH SIGNATURES
Name: Jeannie Irwong

Name: Gary Allan
WITNESS AS TO BOTH SIGNATURES

Address: Suite 900, 1355 West
Broadway, Vancouver, B.C.
Development Coordinator
OCCUPATION OF WITNESS

Name: D. ATKAR
WITNESS AS TO BOTH SIGNATURES

Address: 650 W. GEORGIA VANCOUVER
V6B 4N7

Occupation: BANKER

ON BEHALF OF HER MAJESTY
THE QUEEN IN RIGHT OF THE
PROVINCE OF BRITISH COLUMBIA as
represented by the Minister of Water,
Land and Air Protection in
respect of Covenant B049501 and

THE CITY OF COQUITLAM, THE REGISTERED OWNER OF THE
COVENANTS BP49501, BT110232, BT281744, BT281747,
BT281749, BT281751, BT281753, BT281767, BT281768,
BT281786, BT281798, BT281806, BT281810, AND BV73089
HEREBY CONSENT TO THE DEPOSIT OF THIS PLAN.
AUTHORIZED SIGNATURES

APPROVED AS PHASE ONE OF A THREE PHASE STRATA PLAN
UNDER SECTION 224 OF THE STRATA PROPERTY ACT.

DATE: March 08/04

[Signature]
APPROVING OFFICER
CITY OF COQUITLAM

[Signature]
APPROVING OFFICER
CITY OF COQUITLAM

I, GARY SUNDVICK, A BRITISH COLUMBIA
LAND SURVEYOR CERTIFY THAT THE BUILDINGS INCLUDED
IN THIS STRATA PLAN HAVE NOT, AS OF
FEBRUARY 26, 2004 BEEN PREVIOUSLY OCCUPIED.

[Signature]
B.C.L.S.

I, GARY SUNDVICK, A BRITISH COLUMBIA
LAND SURVEYOR CERTIFY THAT THE BUILDINGS
SHOWN ON THIS STRATA PLAN ARE WITHIN
THE EXTERNAL BOUNDARIES OF THE LAND THAT
IS THE SUBJECT OF THE STRATA PLAN.
DATE: FEBRUARY 26, 2004

[Signature]
B.C.L.S.

FLOOR PLANS
BLOCK 1

STRATA PLAN BCS 790
PHASE 1

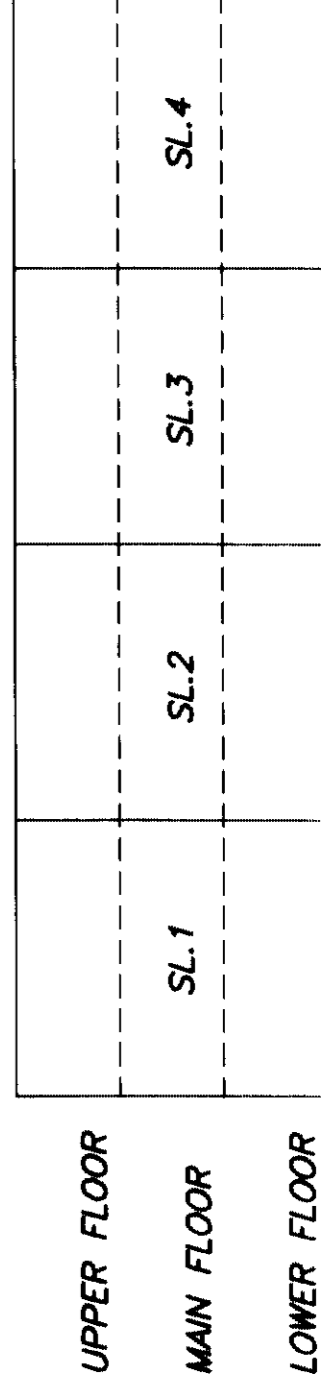
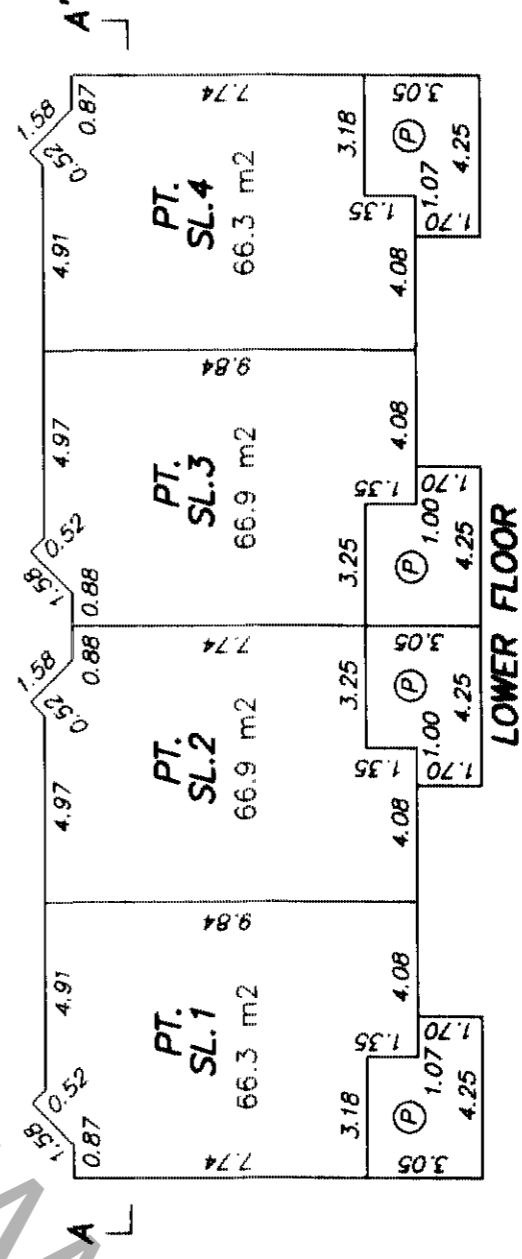
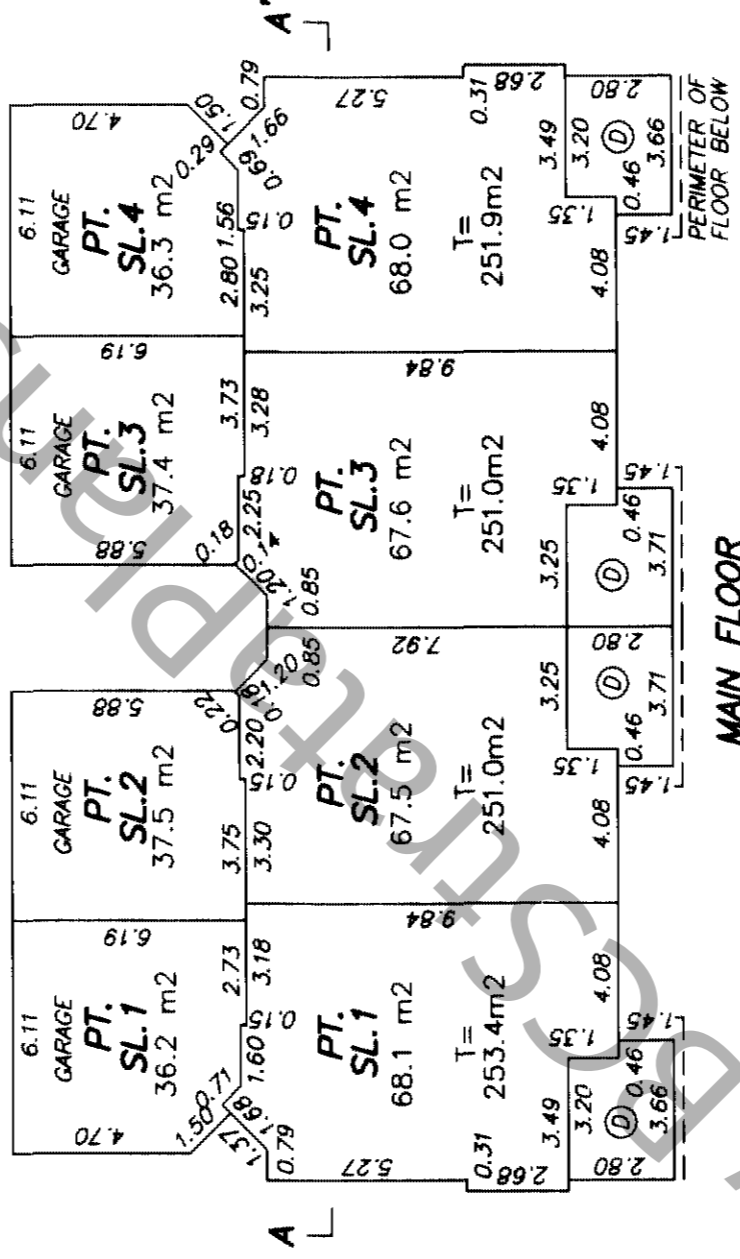
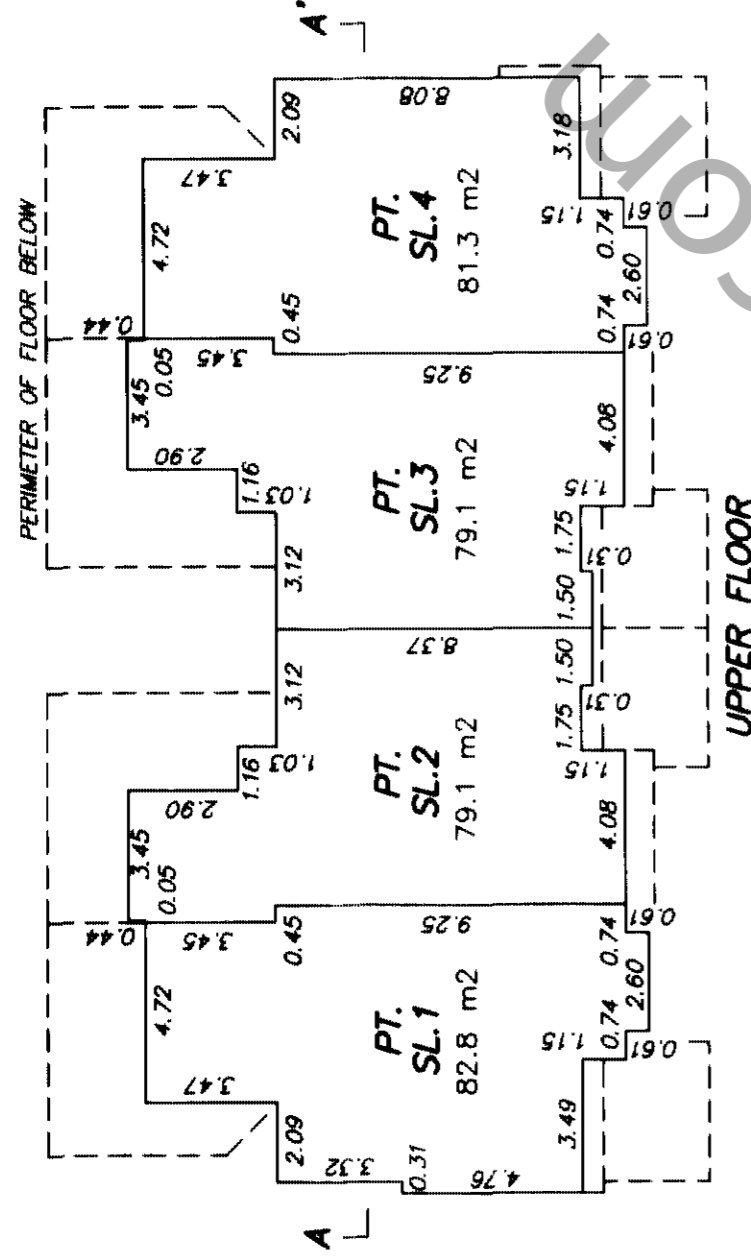

[Handwritten signature]

FLOOR PLANS
BLOCK 2

STRATA PLAN BCS 790
PHASE 1

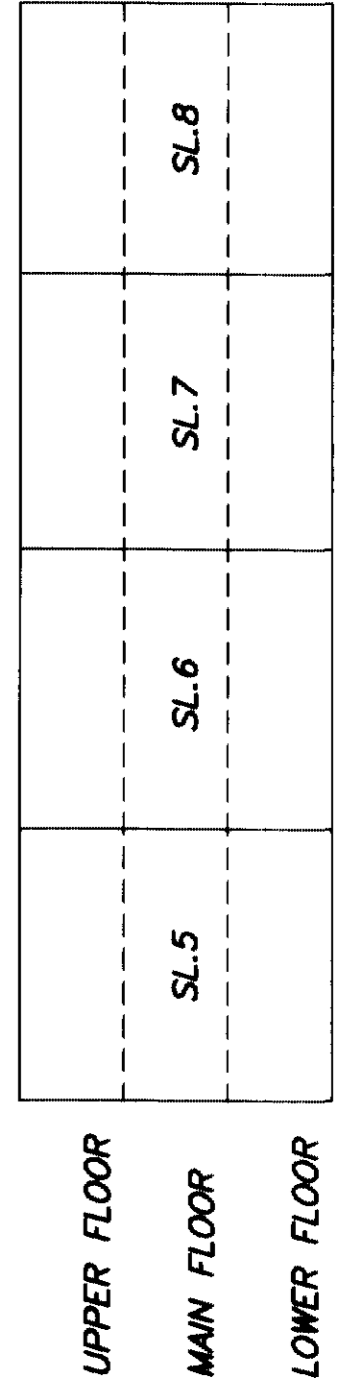
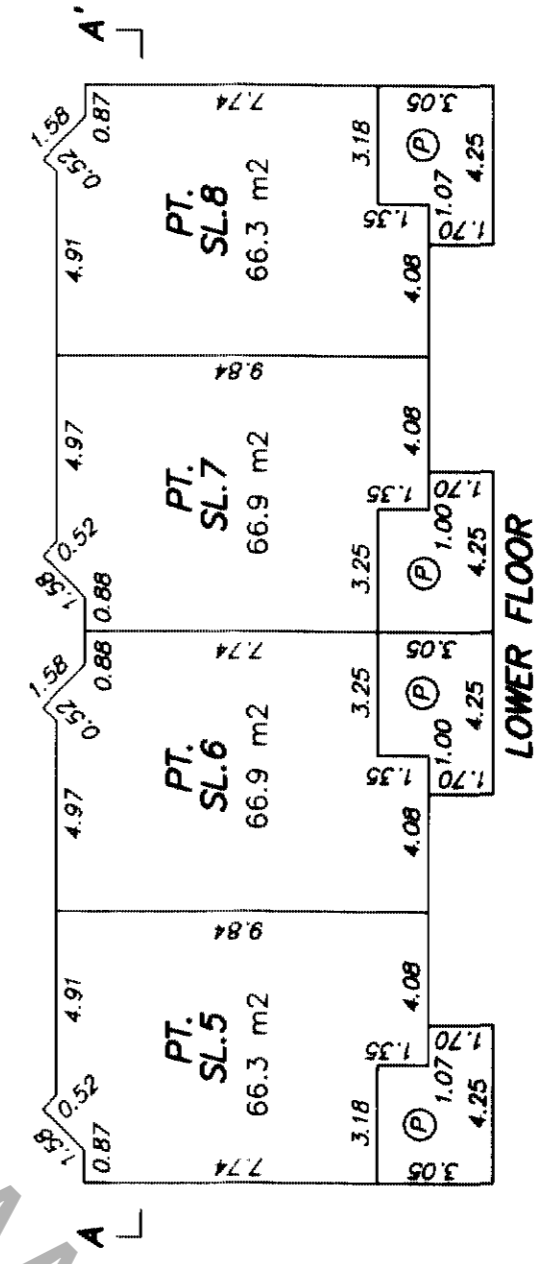
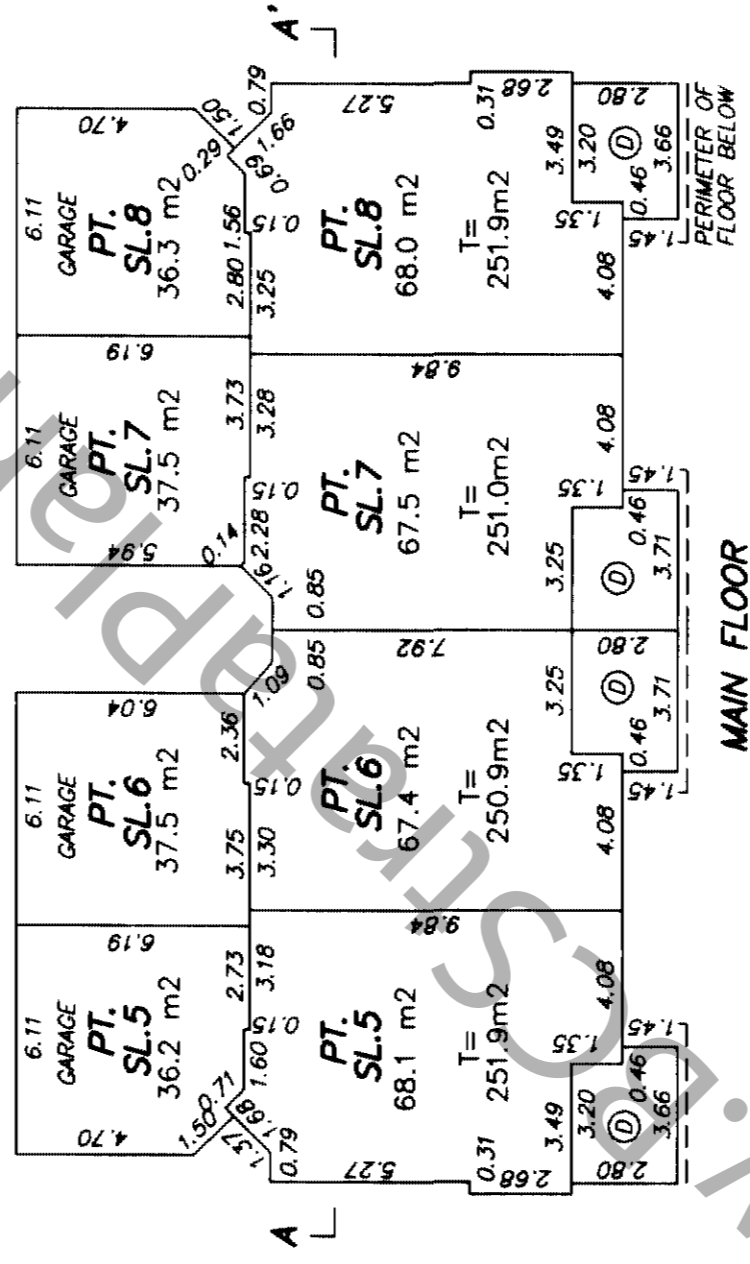
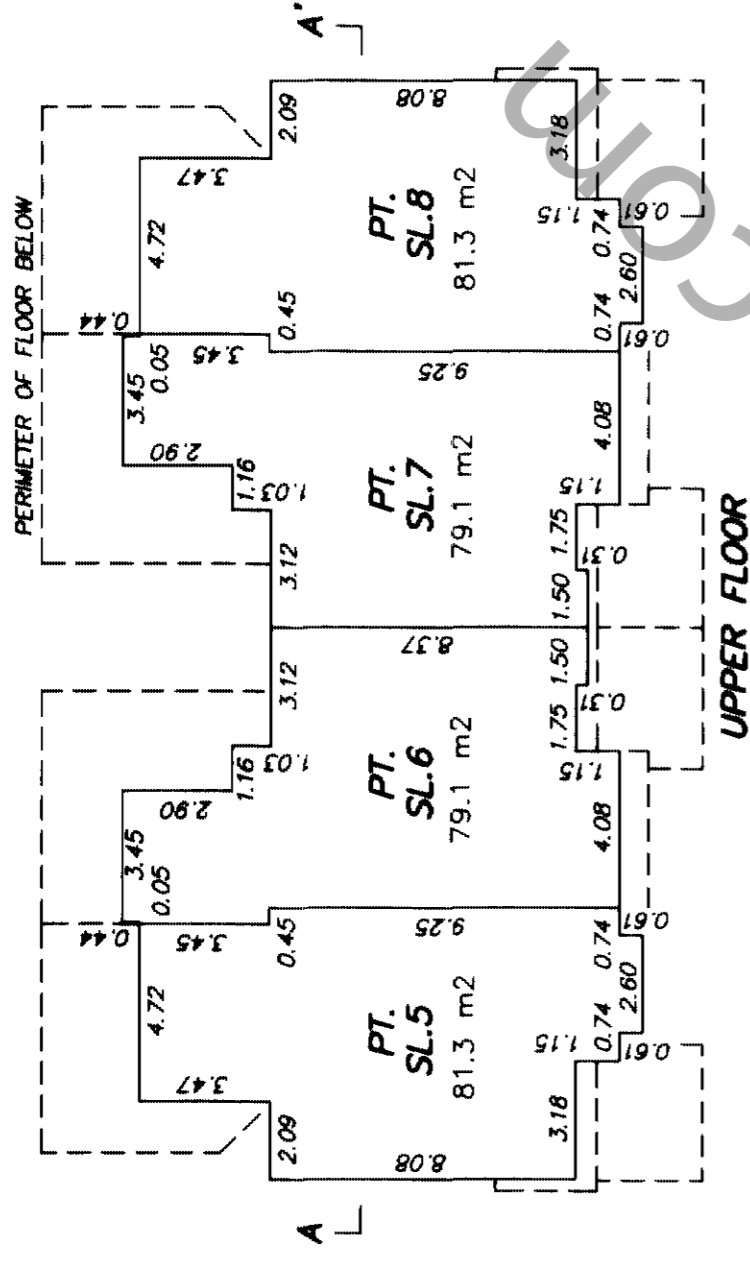

[Signature]
FEBRUARY 26, 2004
FILE: 2935-S13

FLOOR PLANS
BLOCK 3

STRATA PLAN BCS 790
PHASE 1

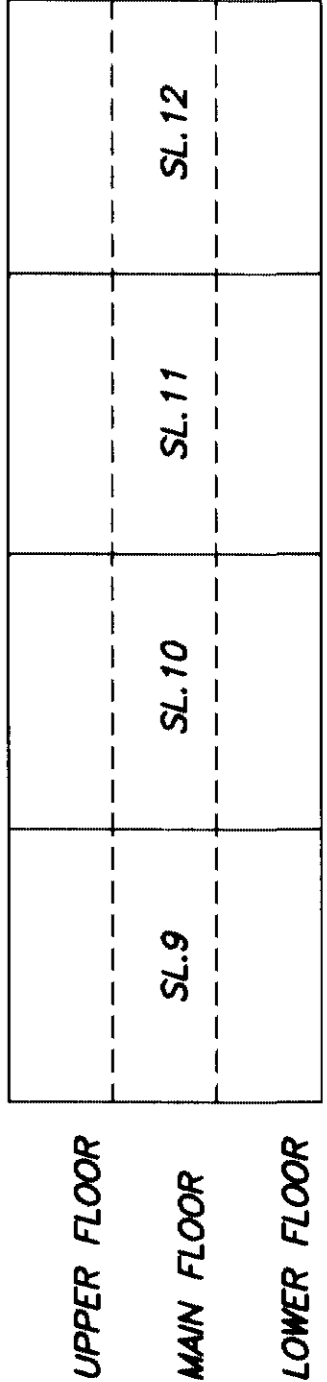
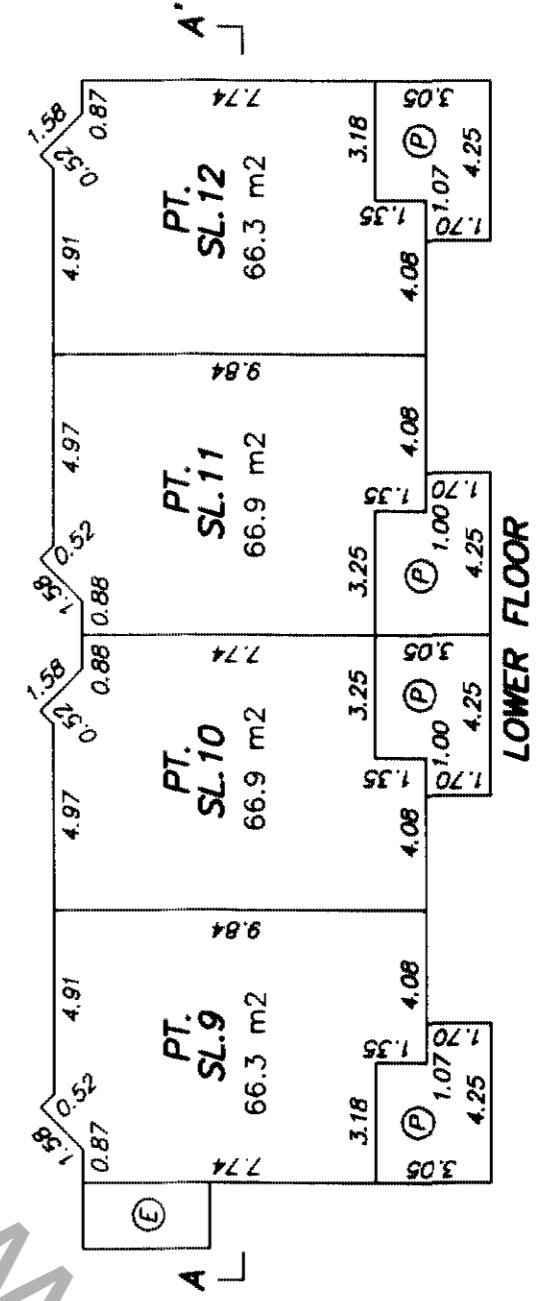
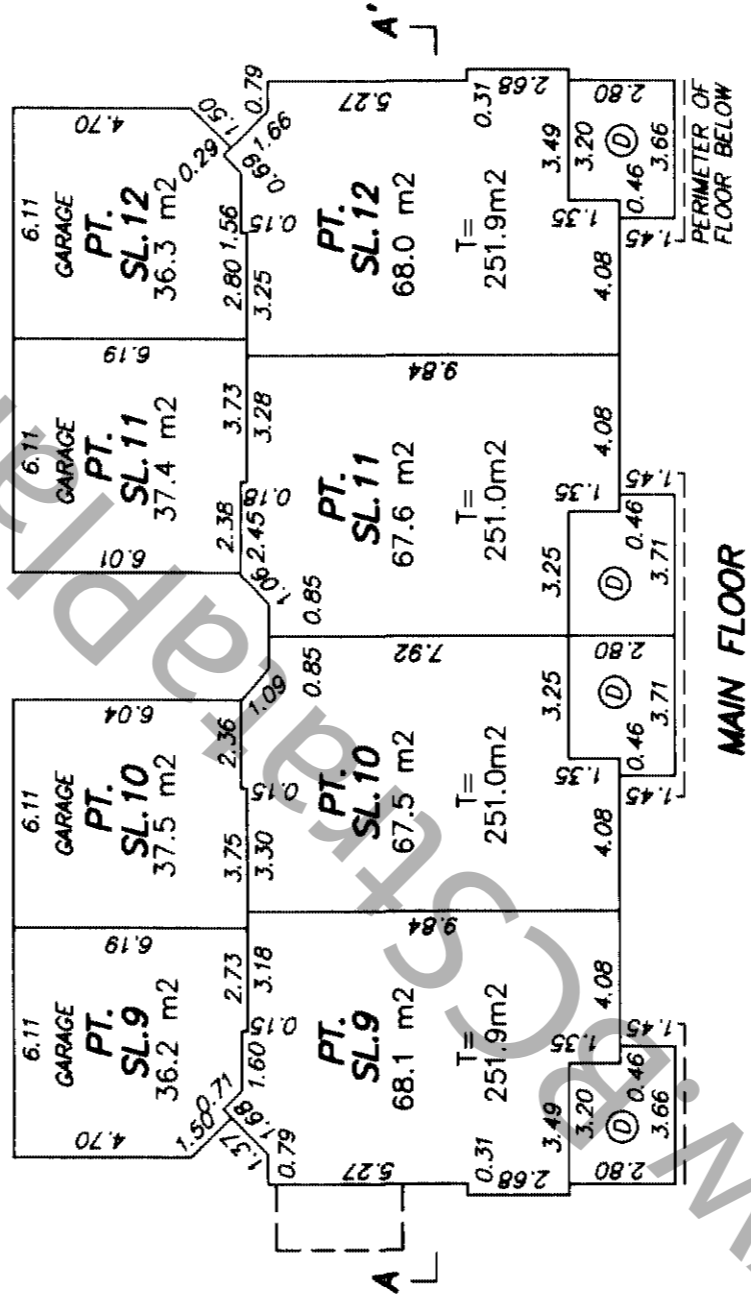
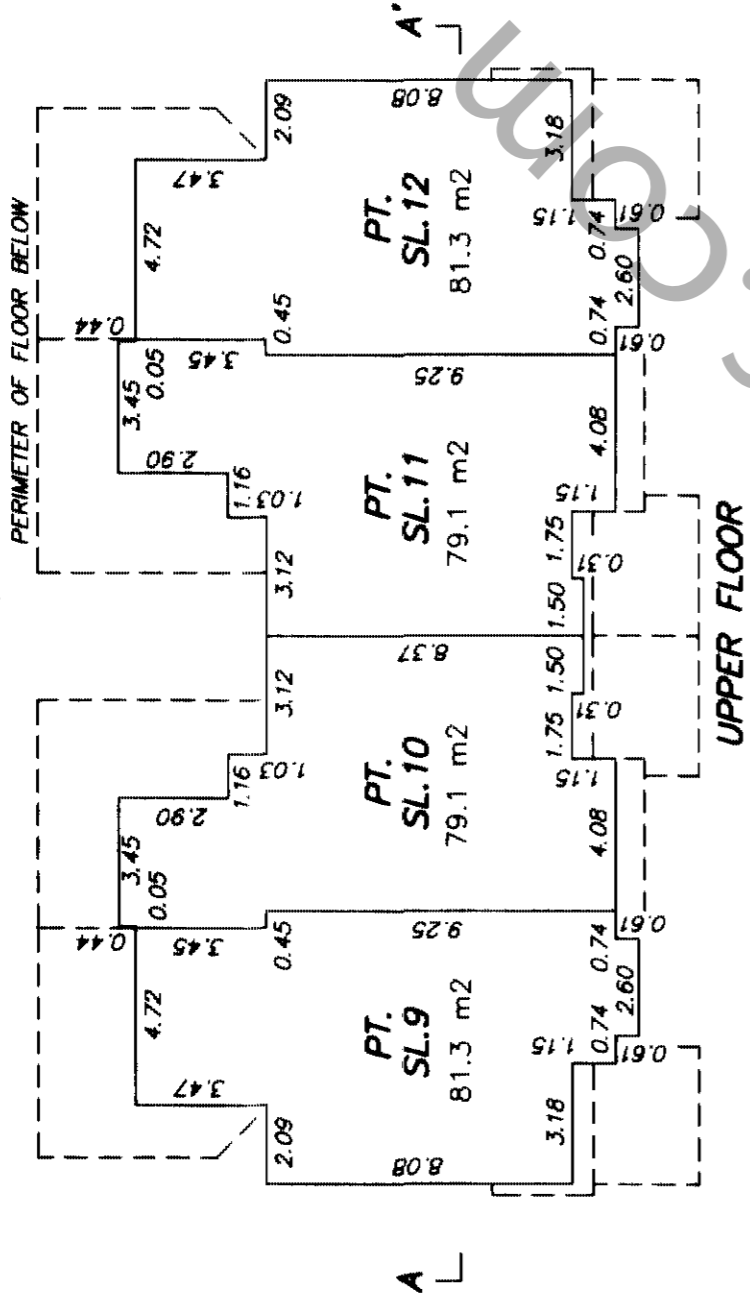
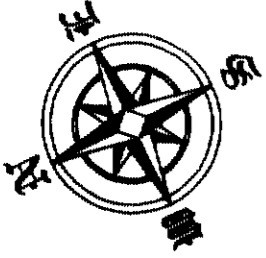

[Signature]

FEBRUARY 26, 2004
FILE: 2935-S13

FLOOR PLANS
BLOCK 4

STRATA PLAN BCS 790
PHASE 1

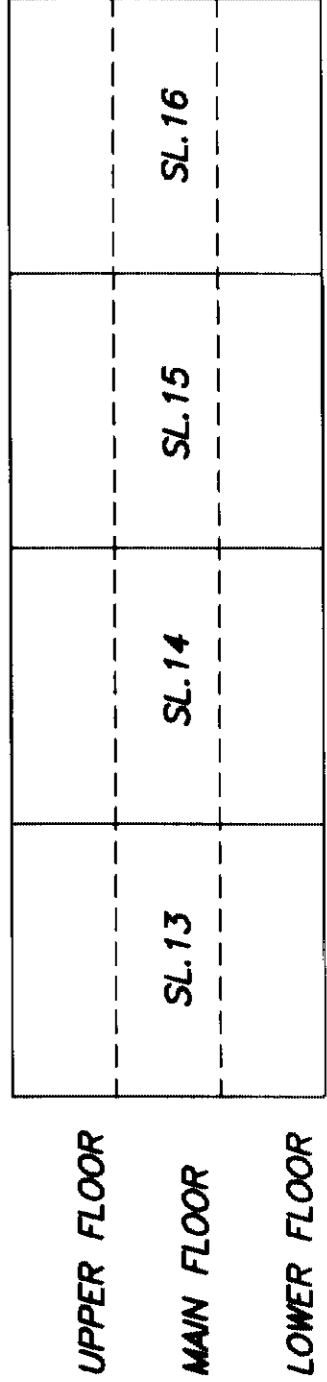
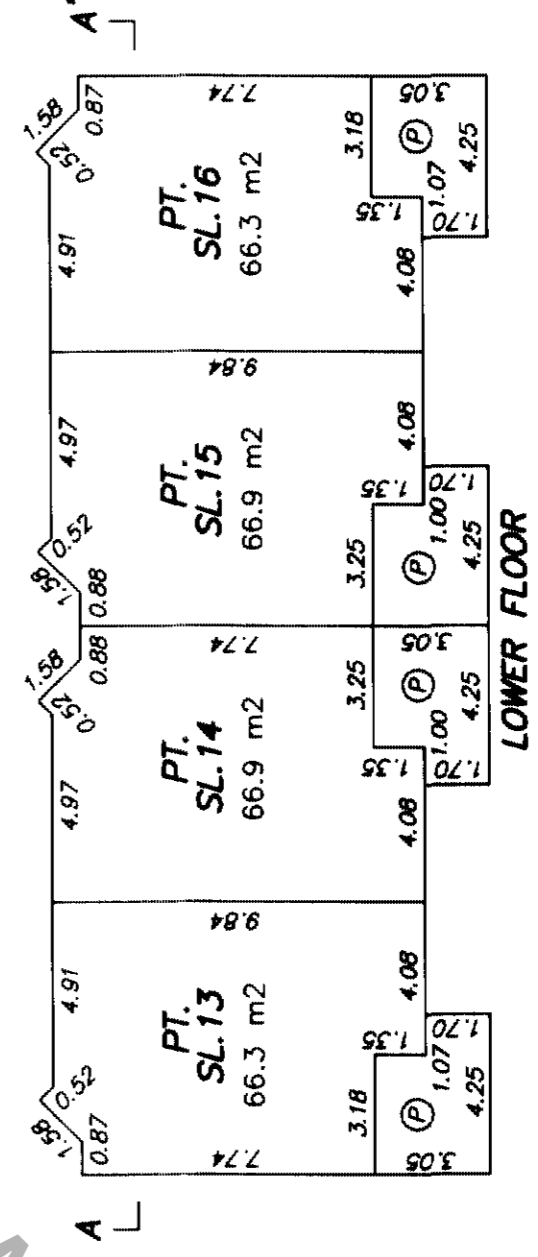
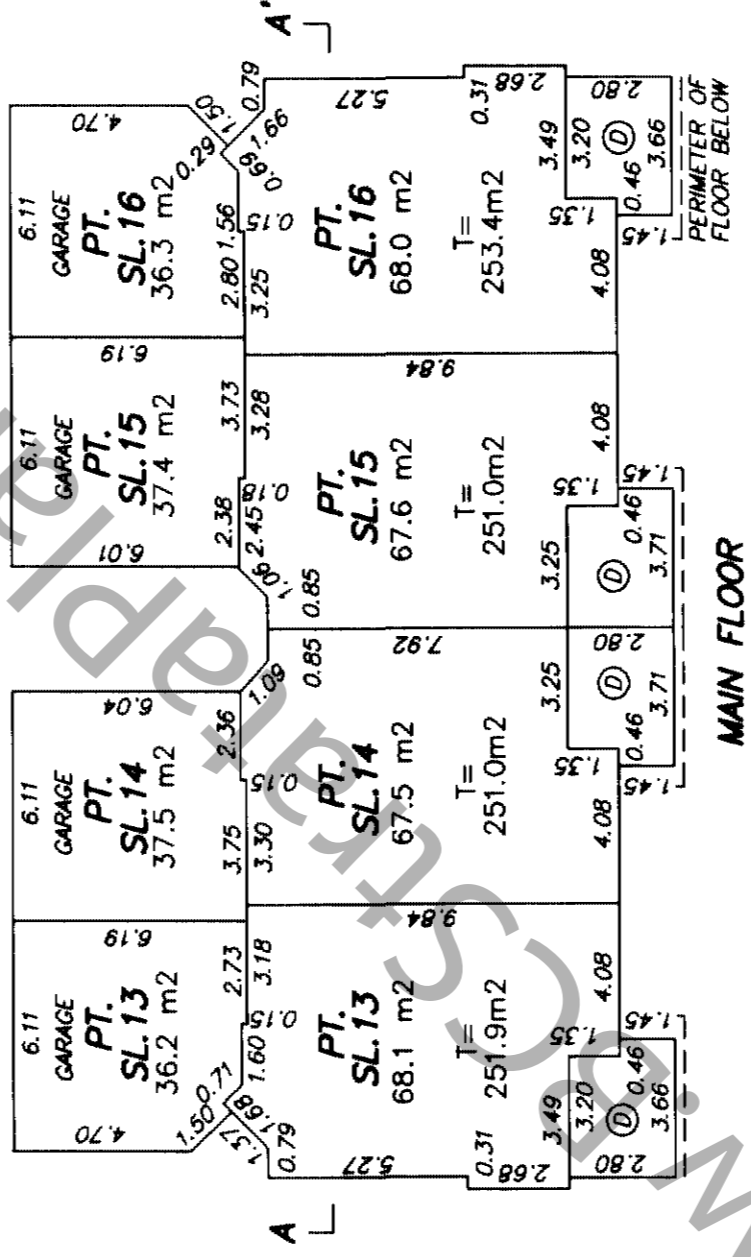
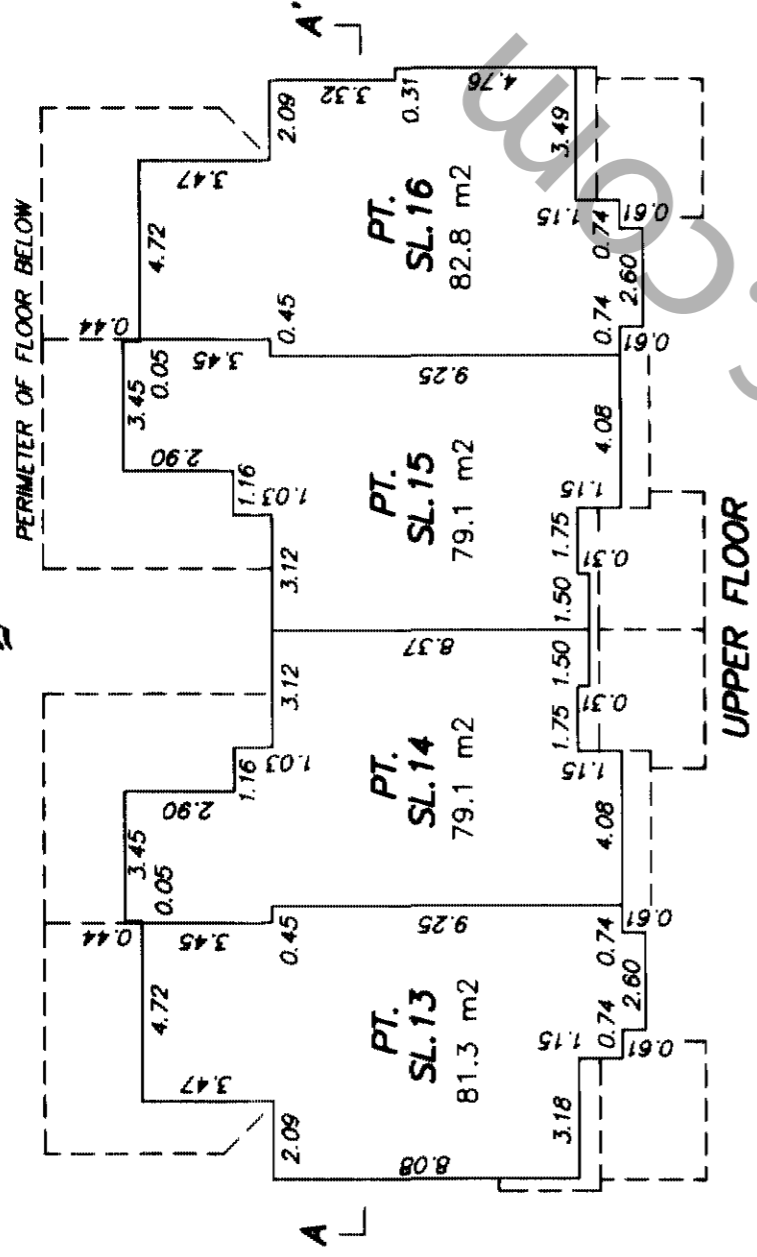
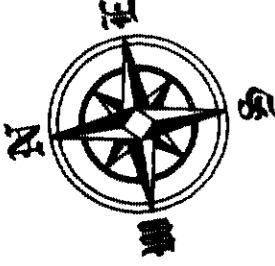

SECTION A-A'

[Signature]
FEBRUARY 26, 2004
FILE: 2935-S13

FLOOR PLANS
BLOCK 5

STRATA PLAN BCS 790
PHASE 1

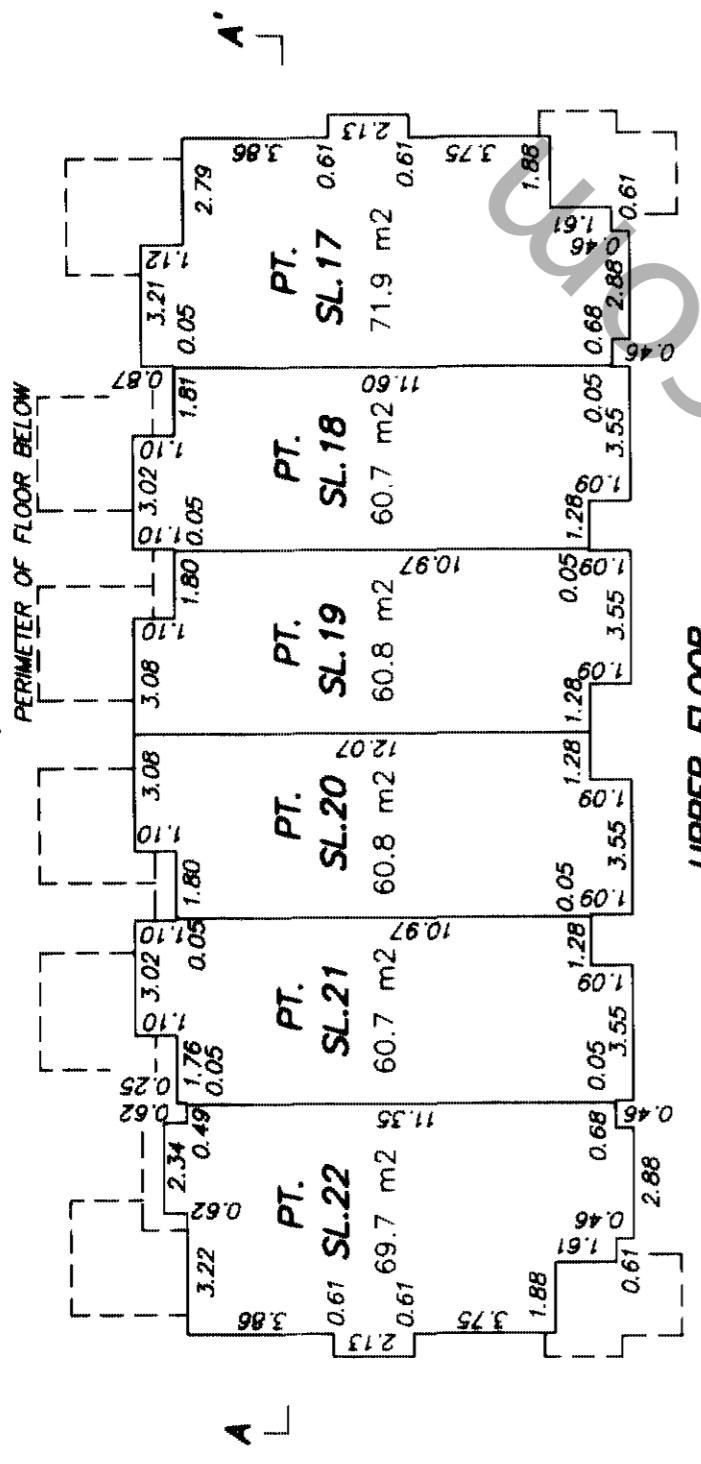

UPPER FLOOR

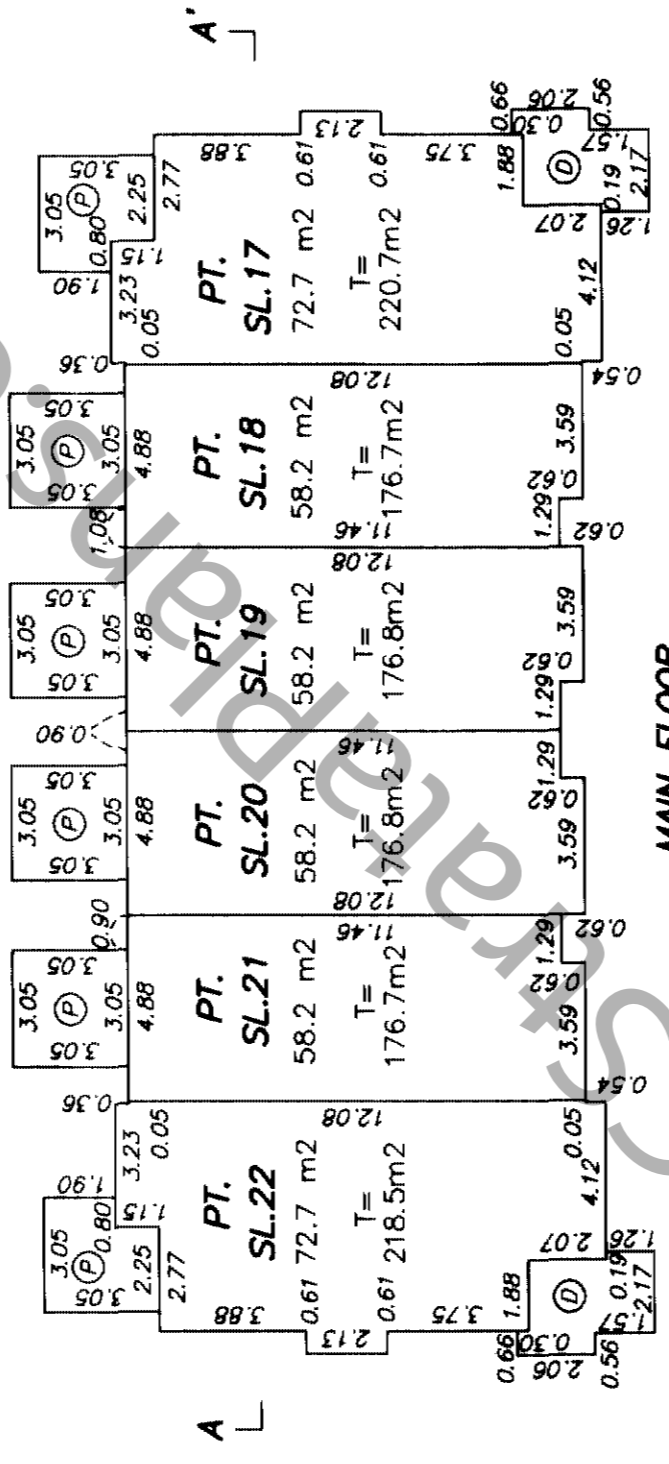

MAIN FLOOR

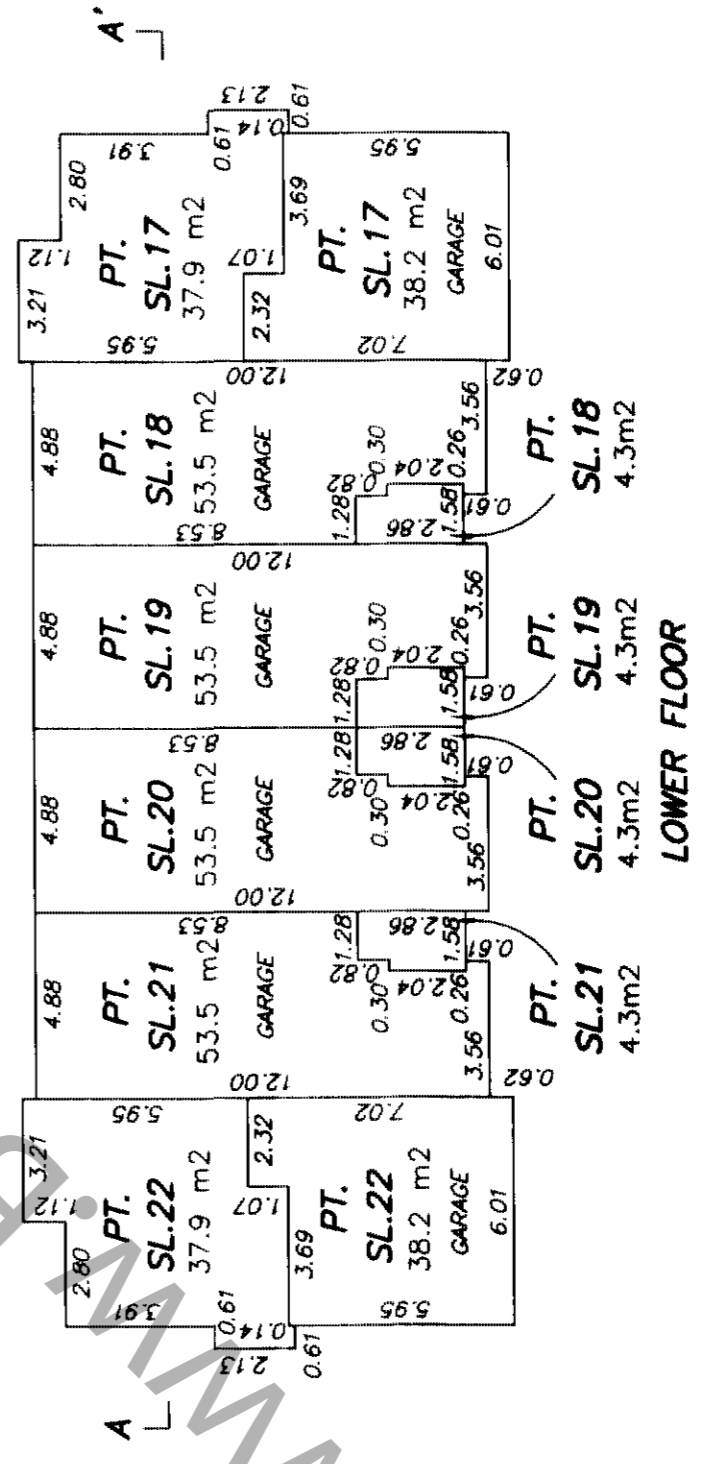

LOWER FLOOR

UPPER FLOOR	MAIN FLOOR	LOWER FLOOR
	SL.22	
	SL.21	GARAGE
	SL.20	GARAGE
	SL.19	GARAGE
	SL.18	GARAGE
	SL.17	

SECTION A-A'

**FLOOR PLANS
BLOCK 6**

**STRATA PLAN BCS 790
PHASE 1**



0 5 10 15
SCALE 1:200
DISTANCES ARE METRIC

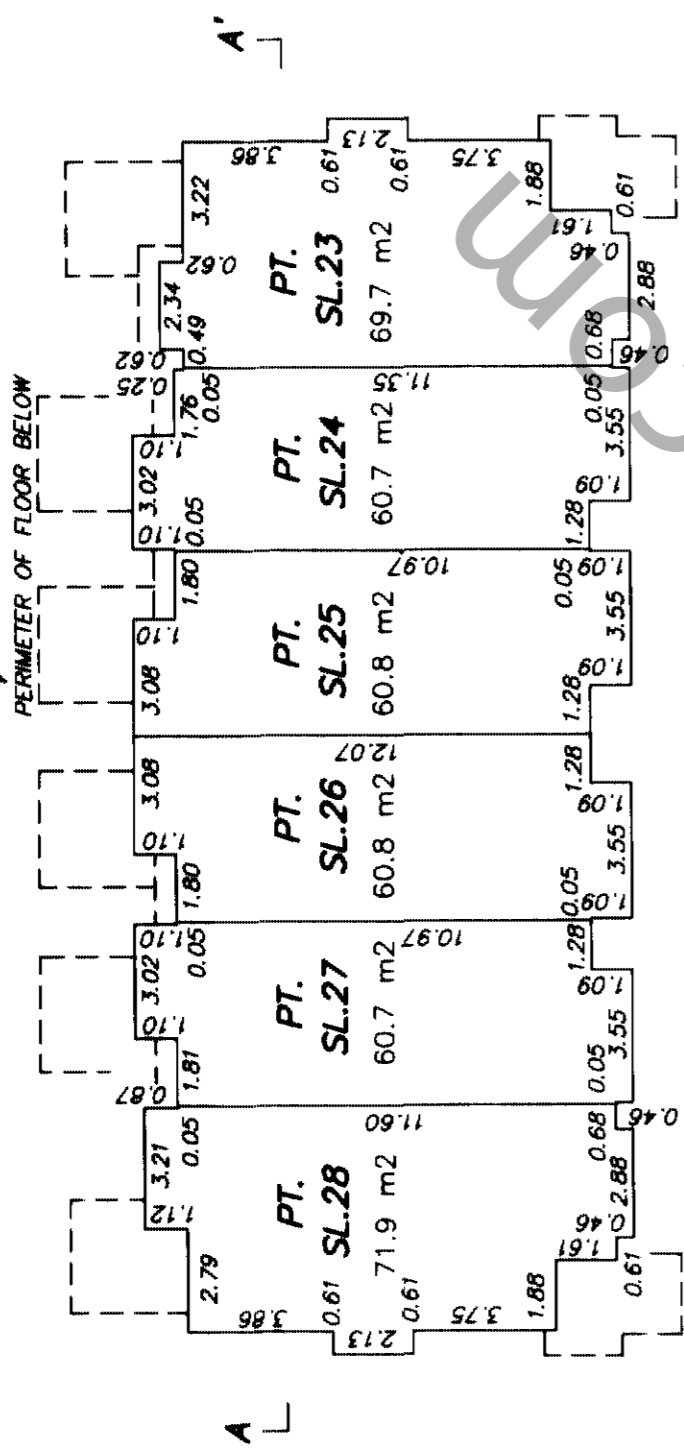

UPPER FLOOR

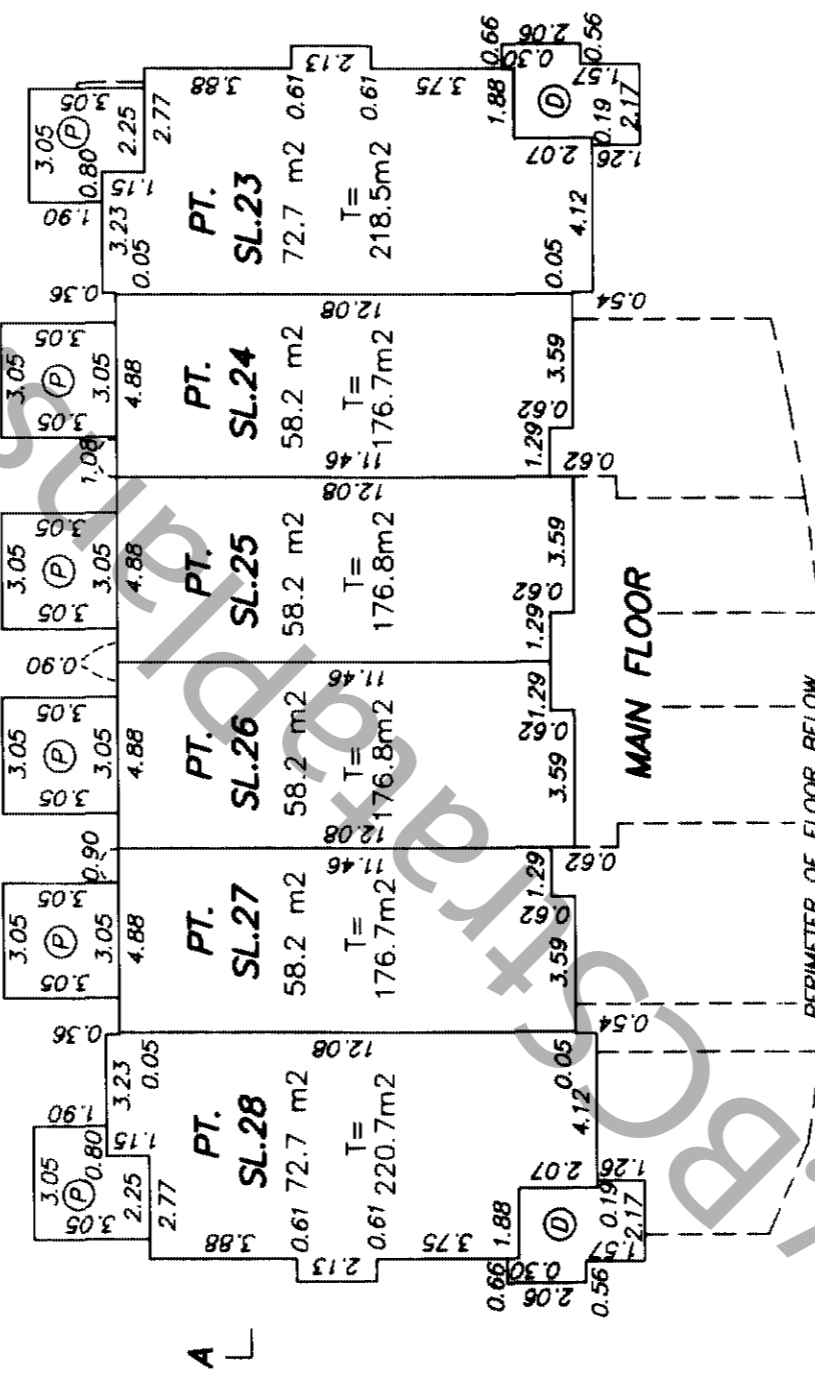

MAIN FLOOR

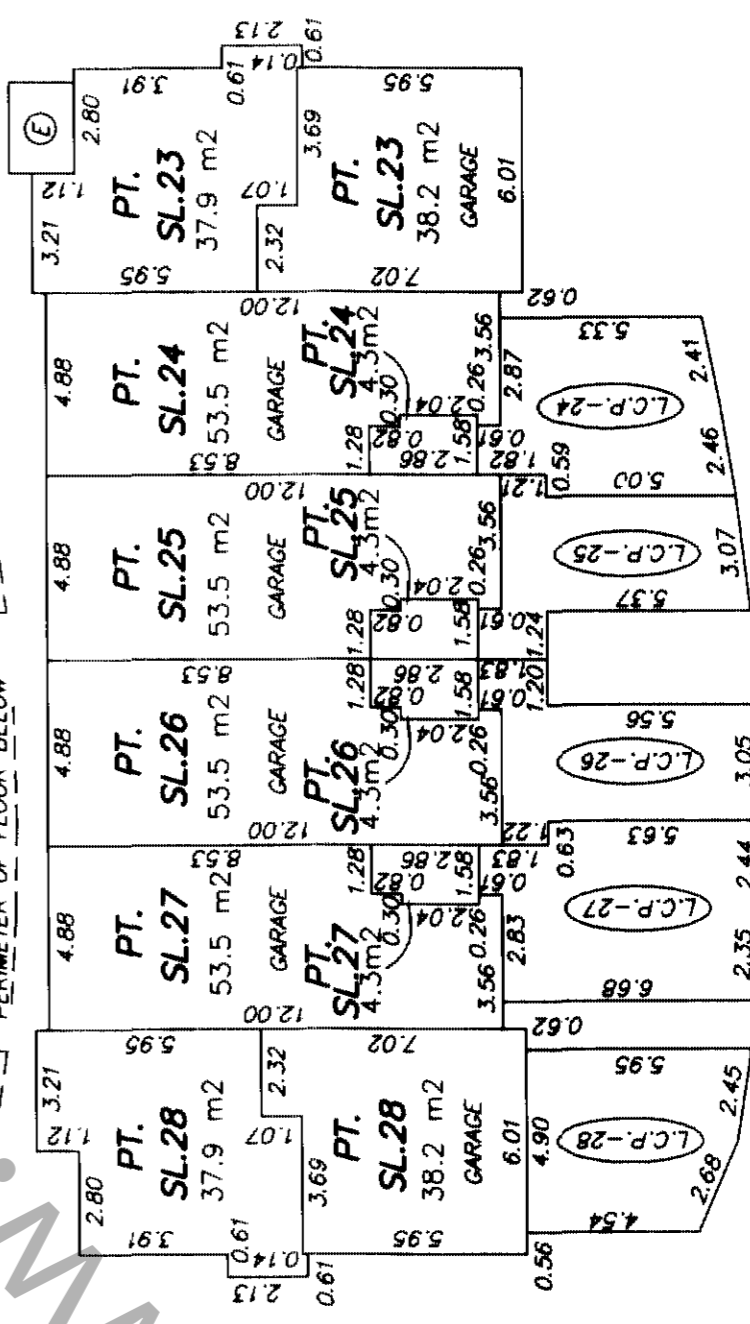

LOWER FLOOR

UPPER FLOOR						
MAIN FLOOR	SL.28	SL.27	SL.26	SL.25	SL.24	SL.23
LOWER FLOOR						

SECTION A-A'

FEBRUARY 26, 2004
FILE: 2935-S13

FLOOR PLANS
BLOCK 7

STRATA PLAN BCS 790
PHASE 1



SCALE 1:200 DISTANCES ARE METRIC

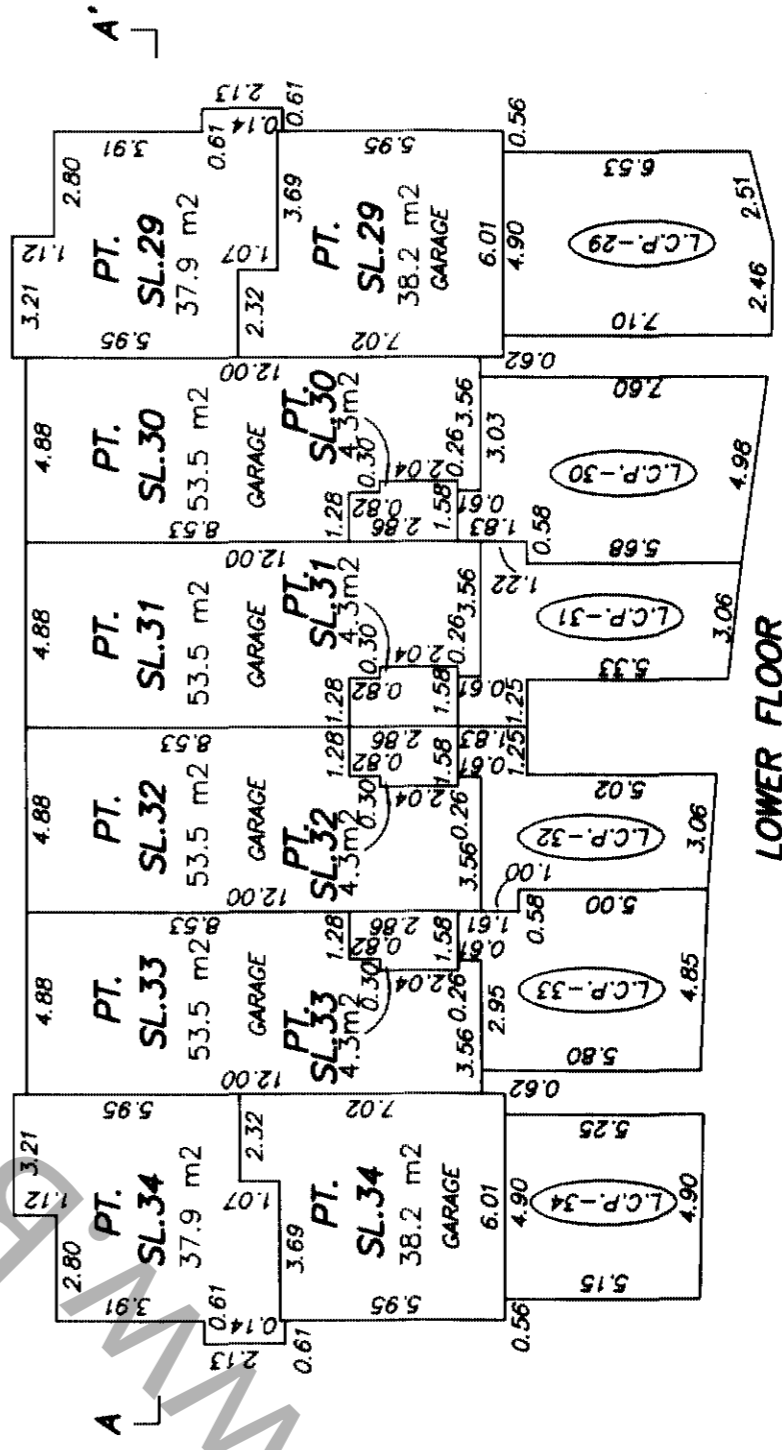
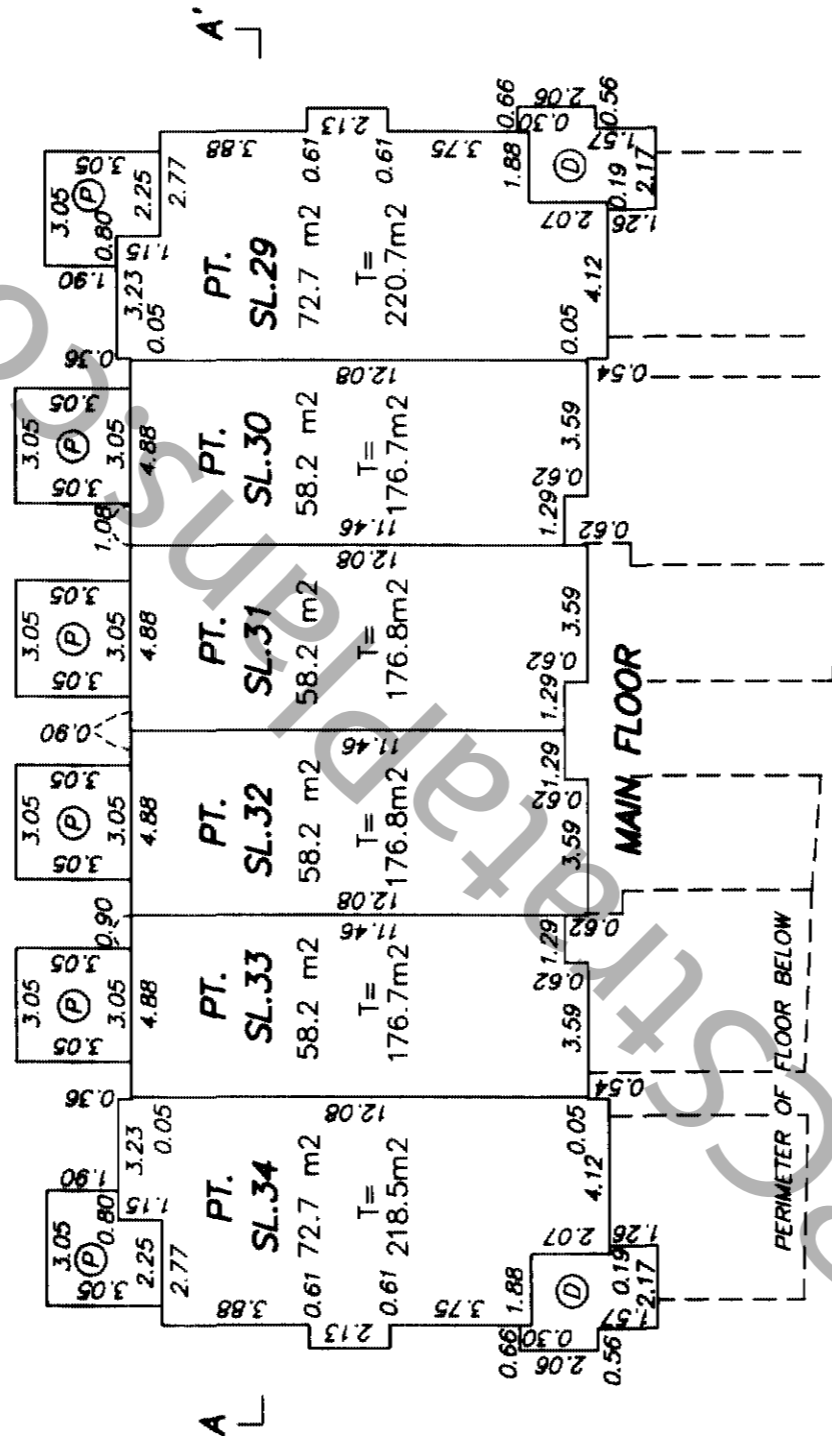
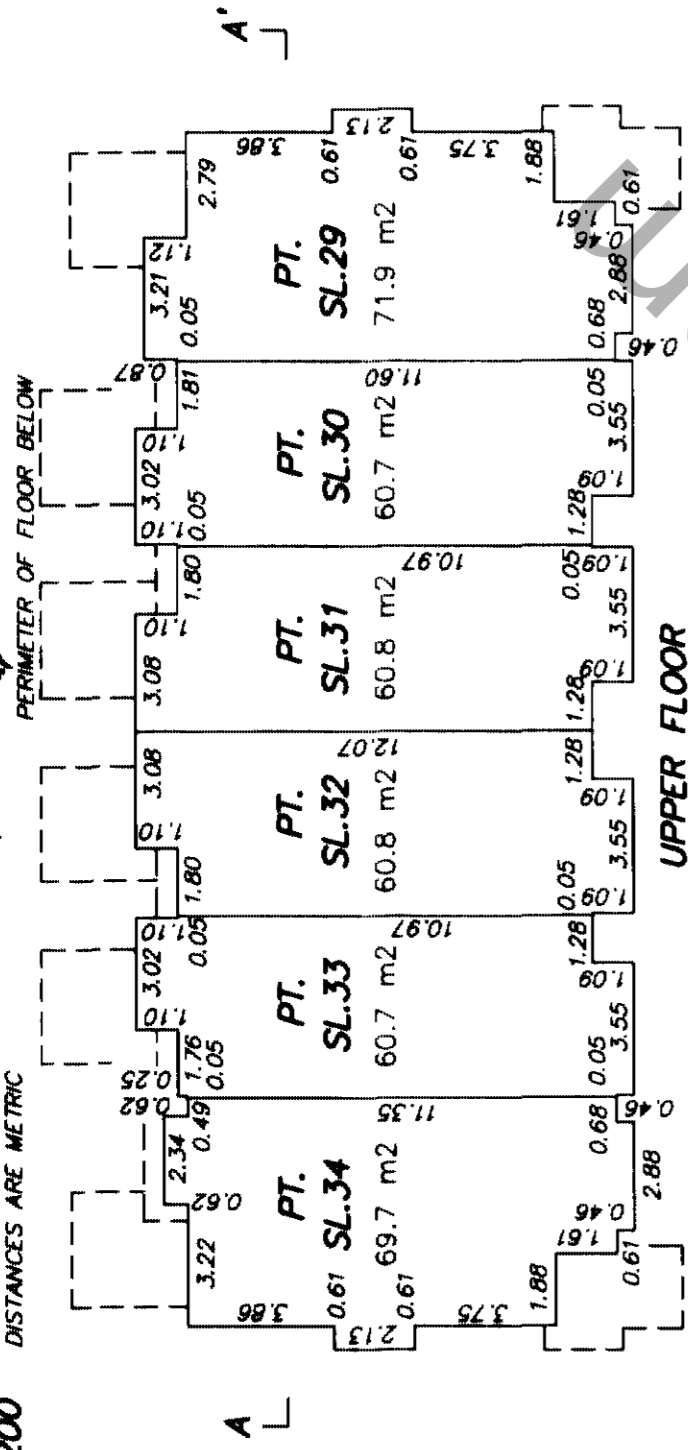

FLOOR	UNIT	TYPE
UPPER FLOOR	SL.34	
UPPER FLOOR	SL.33	
UPPER FLOOR	SL.32	
UPPER FLOOR	SL.31	
UPPER FLOOR	SL.30	
UPPER FLOOR	SL.29	
MAIN FLOOR	SL.34	
MAIN FLOOR	SL.33	
MAIN FLOOR	SL.32	
MAIN FLOOR	SL.31	
MAIN FLOOR	SL.30	
MAIN FLOOR	SL.29	
LOWER FLOOR	SL.34	
LOWER FLOOR	SL.33	
LOWER FLOOR	SL.32	
LOWER FLOOR	SL.31	
LOWER FLOOR	SL.30	
LOWER FLOOR	SL.29	

SECTION A-A'

[Signature]

FLOOR PLANS
BLOCK 8

STRATA PLAN BCS 790
PHASE 1



SCALE 1:200 DISTANCES ARE METRIC

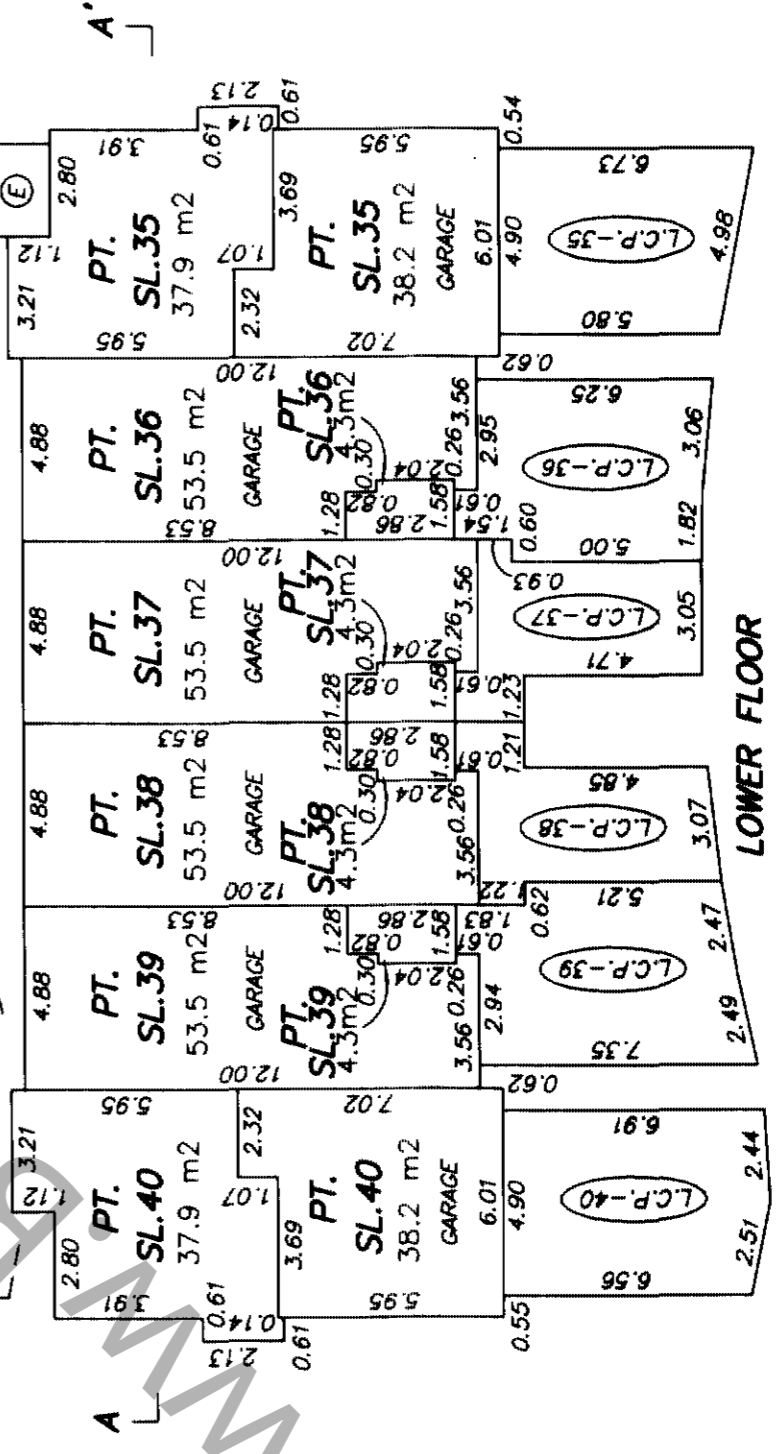
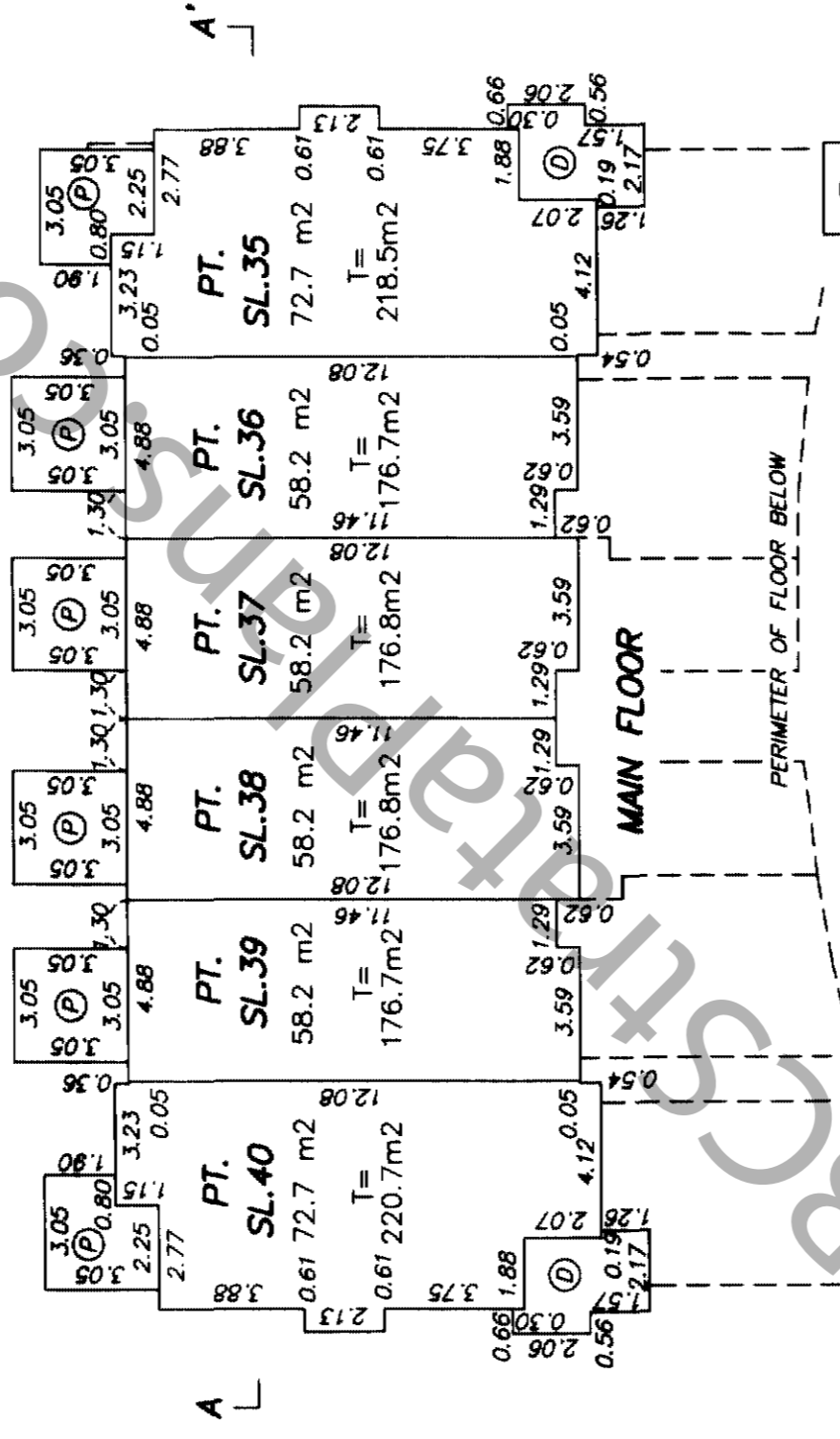
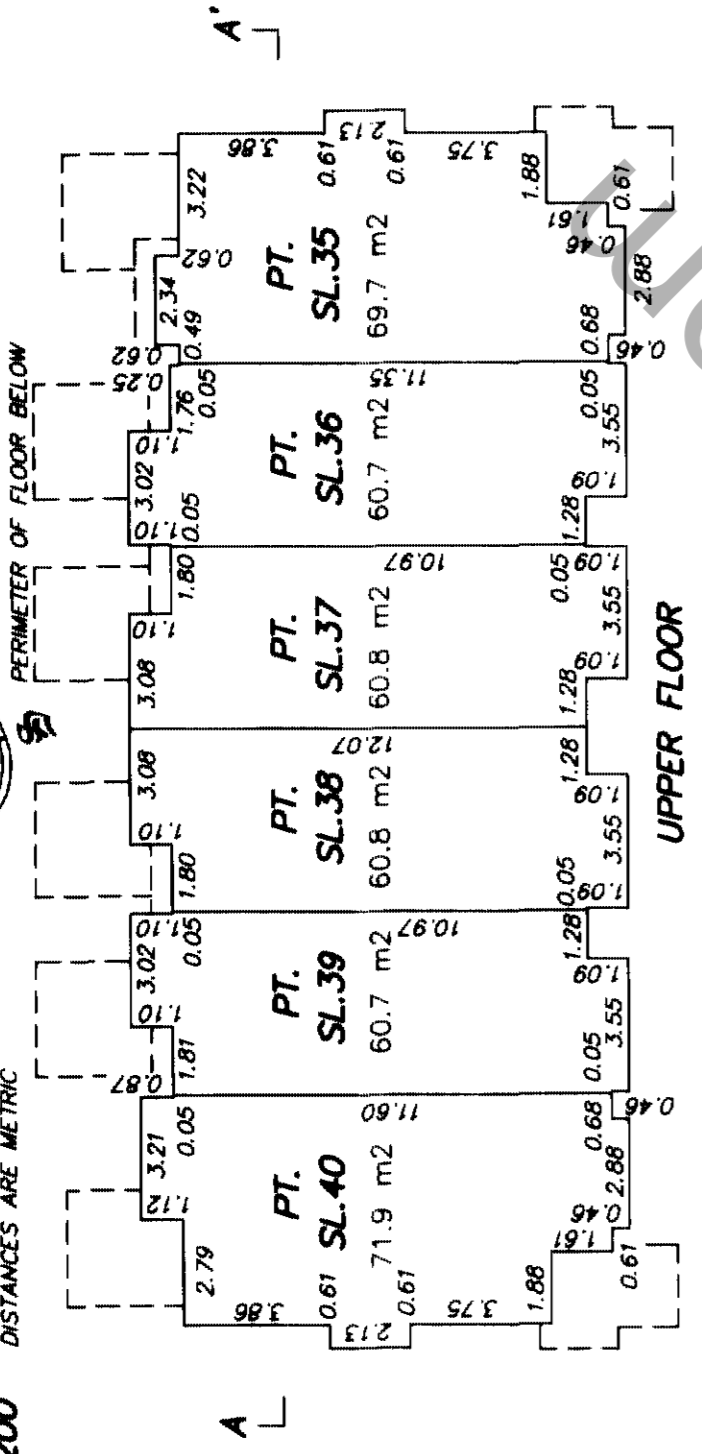

UPPER FLOOR					
MAIN FLOOR	SL.40	SL.39	SL.38	SL.37	SL.36
LOWER FLOOR					

SECTION A-A'

[Signature]

**STRATA PLAN OF PART OF LOT 2
EXCEPT FIRSTLY: PHASE ONE STRATA PLAN BCS790
SECTION 14 TOWNSHIP 39
NEW WESTMINSTER DISTRICT PLAN BCP481**

CITY OF COQUITLAM
B.C.G.S. 92G.027

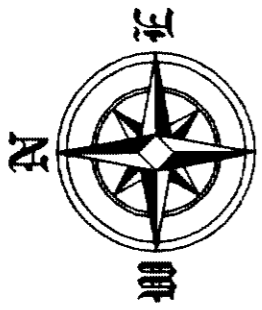
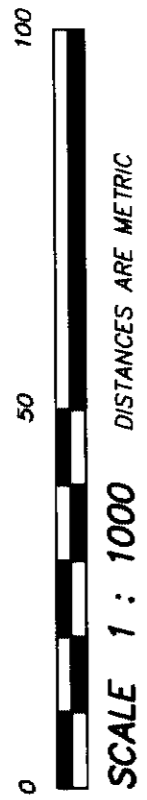

**STRATA PLAN BCS790
PHASE 2**

DEPOSITED AND REGISTERED IN THE LAND
TITLE OFFICE AT NEW WESTMINSTER B.C.
June 10 2004

W. Chens /os
Deputy REGISTRAR
Bw256486-523

**INTEGRATED SURVEY AREA NO. 14 (COQUITLAM)
NAD83(CSRS)**

THIS PLAN SHOWS HORIZONTAL GROUND-LEVEL DISTANCES EXCEPT
WHERE OTHERWISE NOTED. TO COMPUTE GRID DISTANCES, MULTIPLY
GROUND-LEVEL DISTANCES BY COMBINED FACTOR, 0.99995970

CIVIC ADDRESS:
2978 WHISPER WAY
COQUITLAM, B.C.

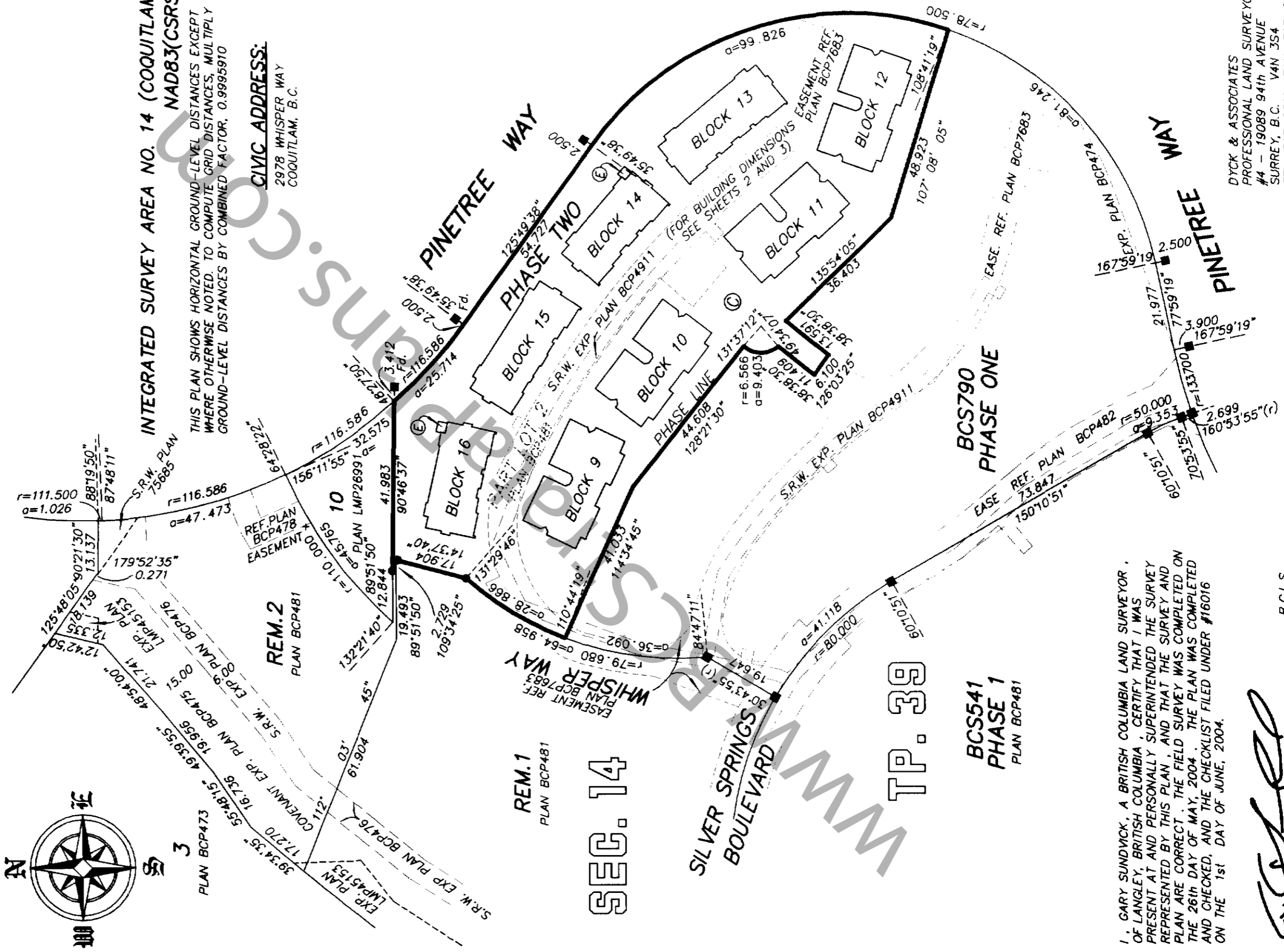

REM.1
PLAN BCP481

REM.2
PLAN BCP481

SEC. 14

BCS541
PHASE 1
PLAN BCP481

I, GARY SUNDVICK, A BRITISH COLUMBIA LAND SURVEYOR,
OF LANGLEY, BRITISH COLUMBIA, CERTIFY THAT I WAS
PRESENT AT AND PERSONALLY SUPERINTENDED THE SURVEY
REPRESENTED BY THIS PLAN, AND THAT THE SURVEY AND
PLAN ARE CORRECT. THE FIELD SURVEY WAS COMPLETED ON
THE 26th DAY OF MAY, 2004. THE PLAN WAS COMPLETED
AND CHECKED, AND THE CHECKLIST FILED UNDER #16016
ON THE 1st DAY OF JUNE, 2004.

G. Sundvick

B.C.L.S.

THIS PLAN LIES WITHIN THE GREATER VANCOUVER REGIONAL DISTRICT

DYCK & ASSOCIATES
PROFESSIONAL LAND SURVEYORS
#4 - 19089 94th AVENUE
SURREY, B.C. V4N 3S4
TEL: 513-9611 FAX: 513-2202
FILE : 2935
DWG : 2935-S20

STRATA PLAN BCS790
PHASE 2

BUILDING LOCATIONS

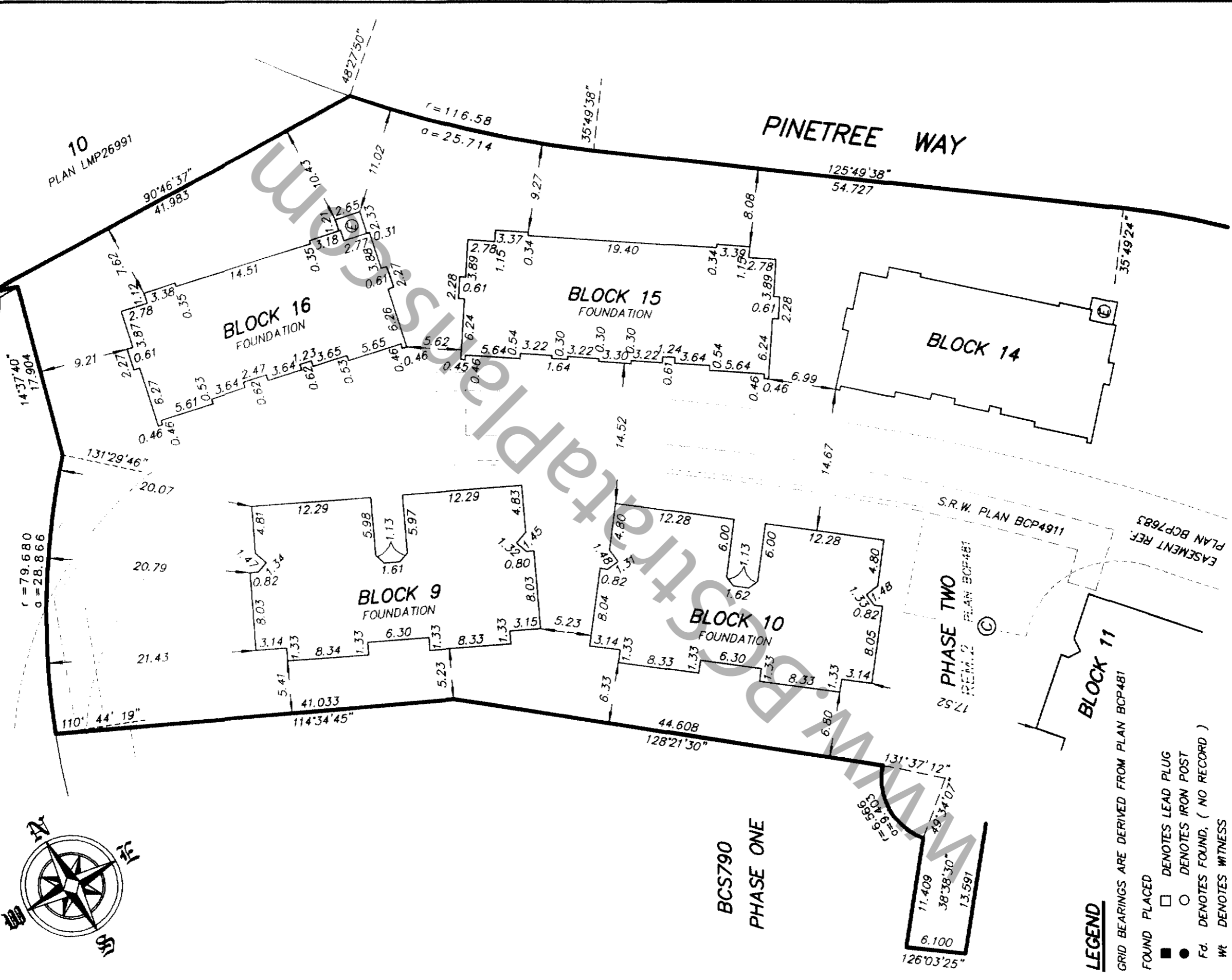
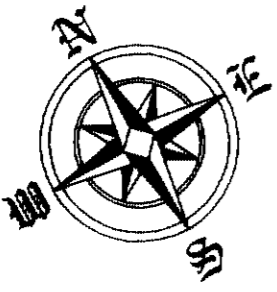
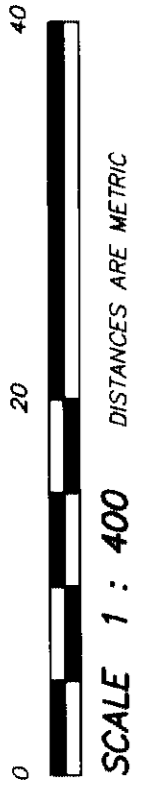

LEGEND

- GRID BEARINGS ARE DERIVED FROM PLAN BCP481
- FOUND PLACED
- DENOTES LEAD PLUG
 - DENOTES IRON POST
 - Fd. DENOTES FOUND, (NO RECORD)
 - Wt DENOTES WITNESS
 - m2 DENOTES SQUARE METRES
 - SL. DENOTES STRATA LOT
 - PT. DENOTES PART
 - T DENOTES TOTAL
 - Ⓢ DENOTES COMMON PROPERTY
 - Ⓣ DENOTES DECK BEING LIMITED COMMON PROPERTY FOR EXCLUSIVE USE OF ADJOINING STRATA LOT
 - Ⓤ DENOTES ELECTRICAL ROOM BEING COMMON PROPERTY
 - Ⓡ DENOTES PATIO BEING LIMITED COMMON PROPERTY FOR EXCLUSIVE USE OF ADJOINING STRATA LOT

[Signature]
MAY 26, 2004
FILE: 2935-S21

STRATA PLAN BCS790
PHASE 2

[Signature]
MAY 26, 2004
FILE:2935-S22

BUILDING LOCATIONS

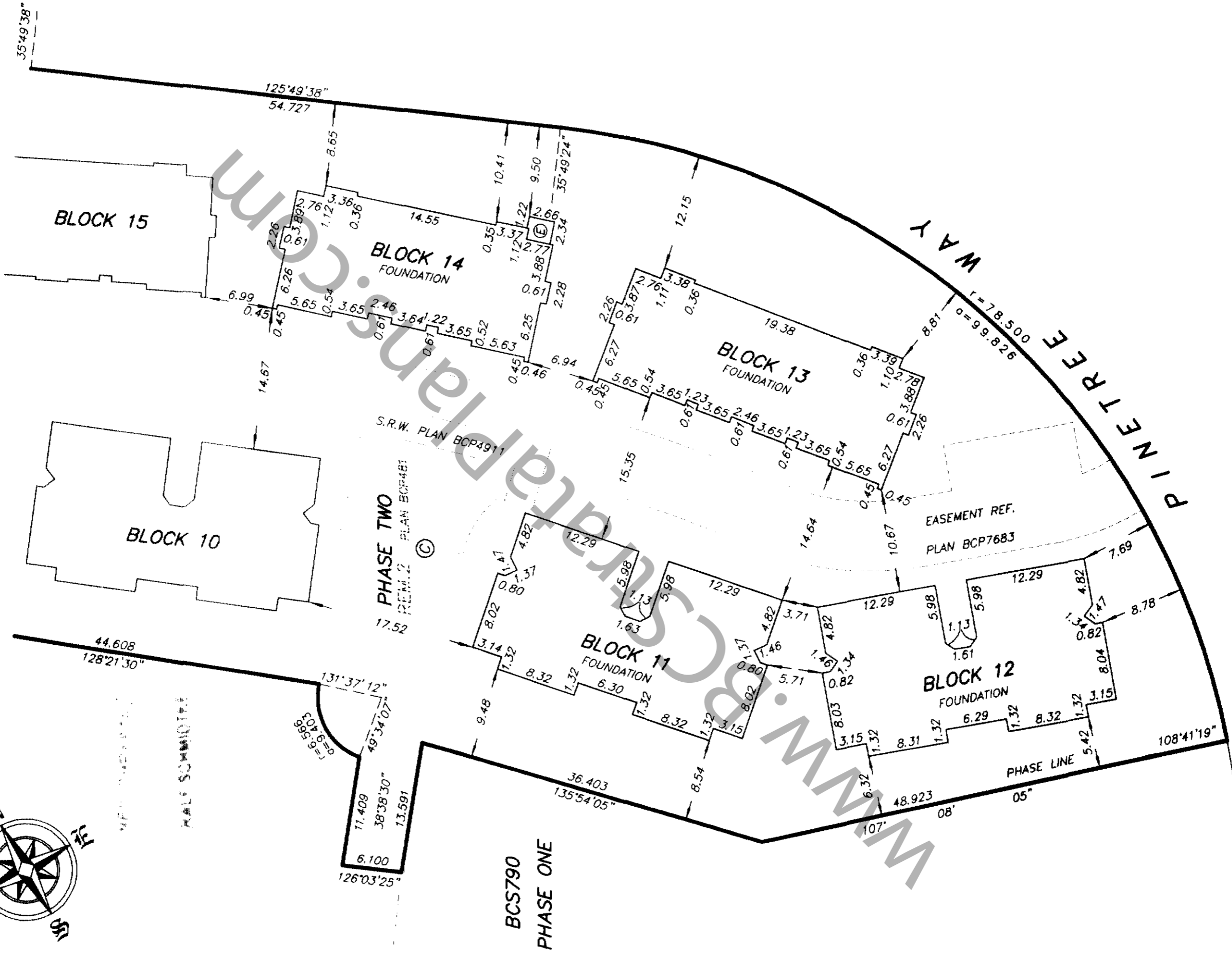
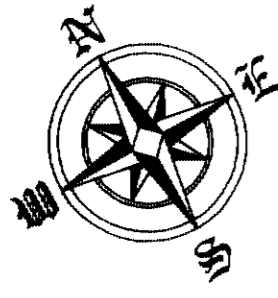
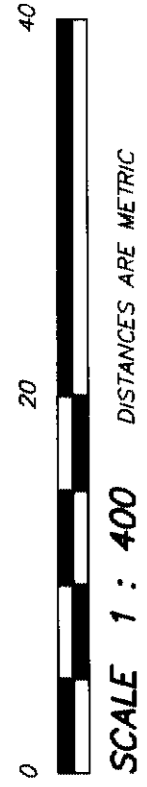

BCS790
PHASE ONE

STRATA PLAN BCS790
PHASE 2

STRATA PROPERTY ACT

OWNER:

POLYGON SILVER SPRINGS DEVELOPMENT LTD.
(INCORPORATION No. 481367)

Neil Chrystal

Name NEIL CHRYS TAL
Authorized Signatory

Ralf Schmidtke

Name RALF SCHMIDTKE
Authorized Signatory

Steve

WITNESS AS TO BOTH SIGNATURES
Name Steve Meyer

Address Suite 900, 1333 West

Broadway, Vancouver, B.C.

Development Coordinator

OCCUPATION: WITNESS

MORTGAGEE:

THE BANK OF NOVA SCOTIA

Patrick Brennan

Name PATRICK BRENNAN
Authorized Signatory

Michael Downing

Name MICHAEL DOWNING
Authorized Signatory

Bong Atkar

WITNESS AS TO BOTH SIGNATURES
Name B. ATKAR

Address 3400 - 650 W. GEORGIA VANCOUVER

V8B 4N7

OCCUPATION: BANKER

THE CITY OF COQUITLAM, THE REGISTERED OWNER OF THE COVENANTS BP49501, BT110232, BT281744, BT281747, BT281749, BT281751, BT281753, BT281767, BT281768, BT281786, BT281798, BT281806, BT281810, AND BV73089 HEREBY CONSENT TO THE DEPOSIT OF THIS PLAN.

AUTHORIZED SIGNATURES

Debra Meyer

APPROVING OFFICER
CITY OF COQUITLAM

APPROVED AS PHASE TWO OF A THREE PHASE STRATA PLAN UNDER SECTION 224 OF THE STRATA PROPERTY ACT.

DATE: JUNE 7, 2004

Debra Meyer

APPROVING OFFICER
CITY OF COQUITLAM

I, GARY SUNDVICK, A BRITISH COLUMBIA LAND SURVEYOR CERTIFY THAT THE BUILDINGS INCLUDED IN THIS STRATA PLAN HAVE NOT, AS OF MAY 26, 2004 BEEN PREVIOUSLY OCCUPIED.

Gary Sundvick

B.C.L.S.

I, GARY SUNDVICK, A BRITISH COLUMBIA LAND SURVEYOR CERTIFY THAT THE BUILDINGS SHOWN ON THIS STRATA PLAN ARE WITHIN THE EXTERNAL BOUNDARIES OF THE LAND THAT IS THE SUBJECT OF THE STRATA PLAN.
DATE: MAY 26, 2004

Gary Sundvick

B.C.L.S.

FLOOR PLANS
BLOCK 9

STRATA PLAN BCS790
PHASE 2

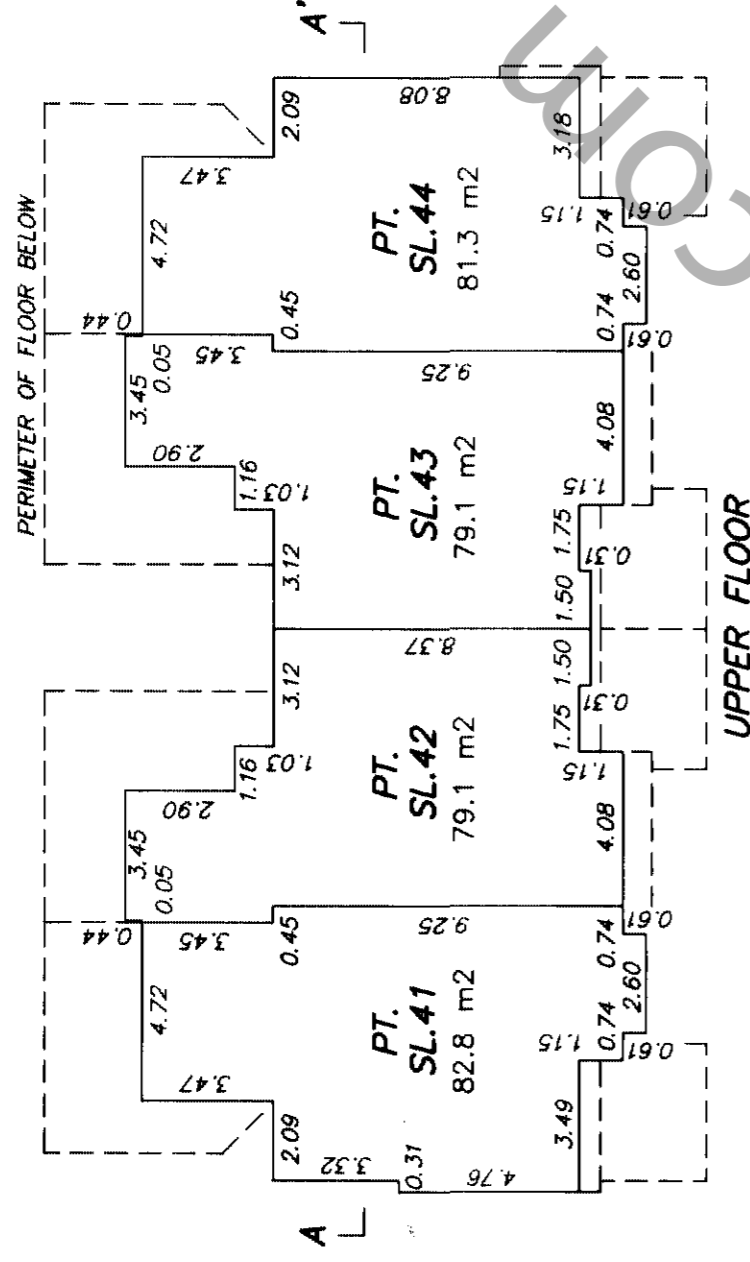
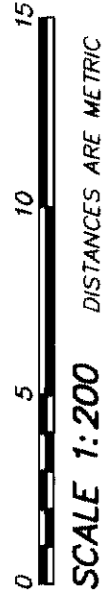
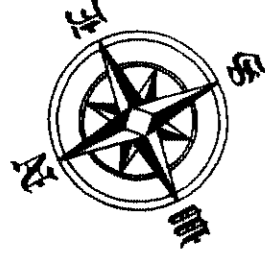

UPPER FLOOR

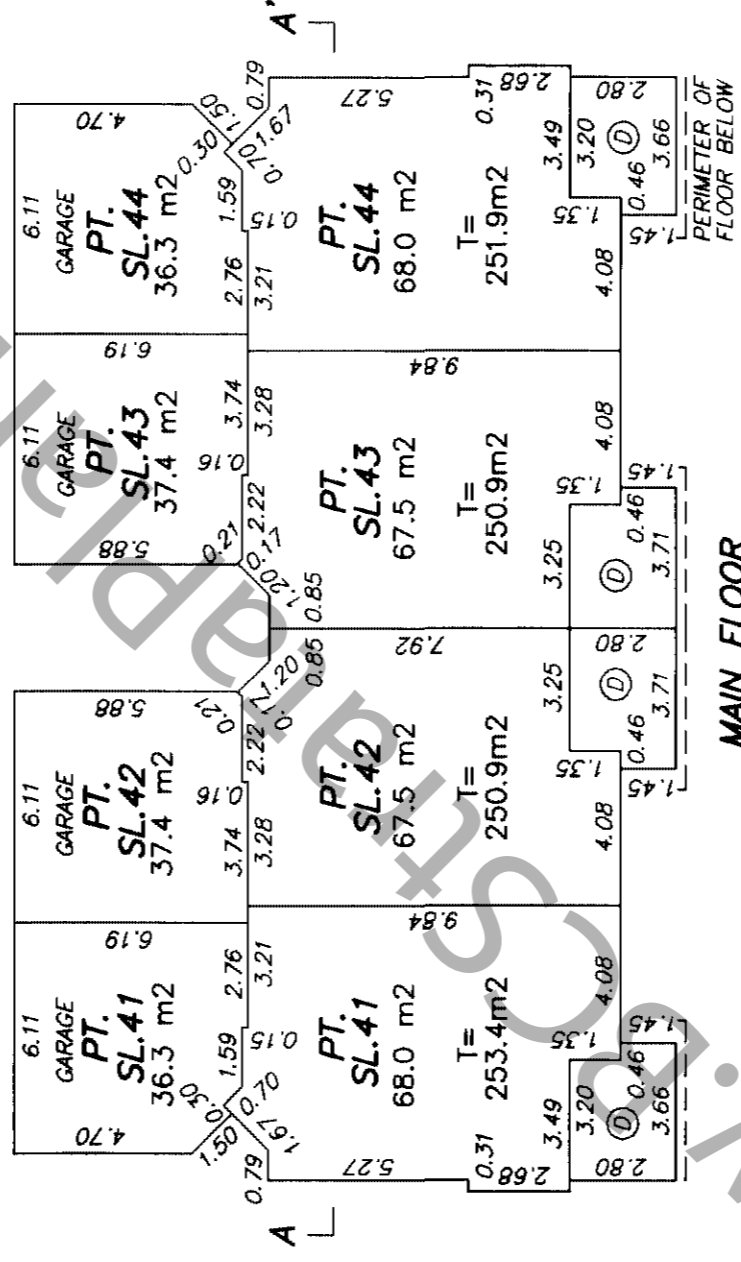

MAIN FLOOR

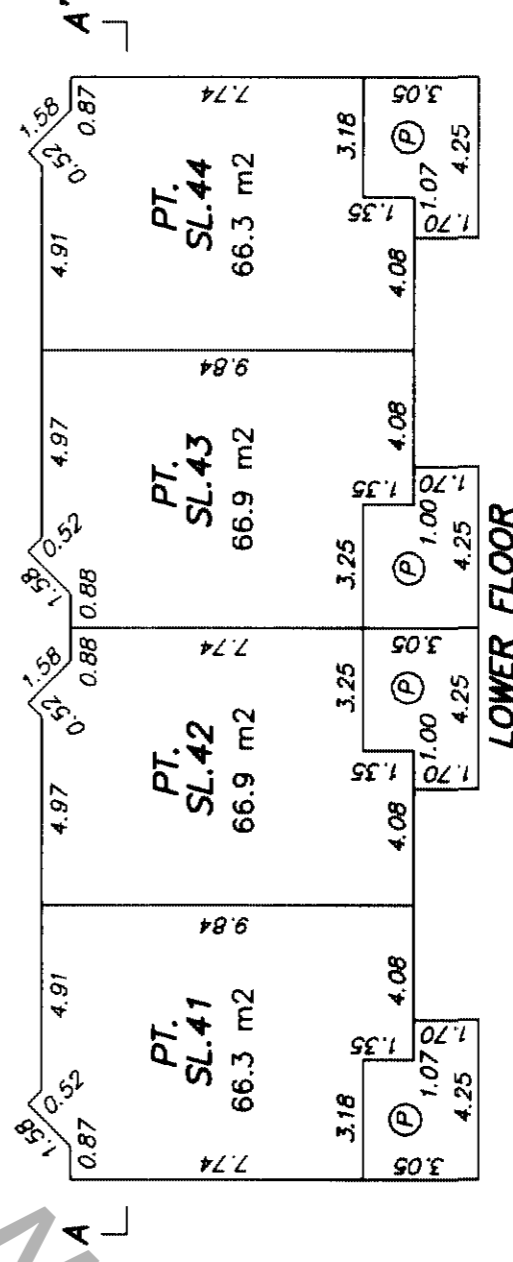

LOWER FLOOR

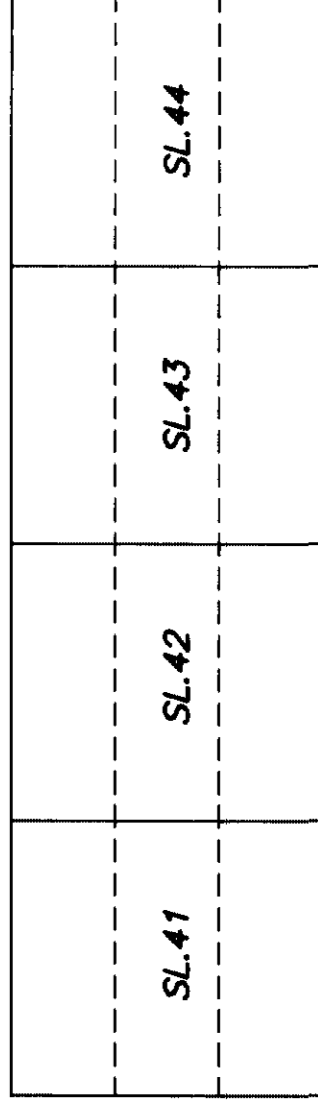

UPPER FLOOR

MAIN FLOOR

LOWER FLOOR

SECTION A-A'

FLOOR PLANS
BLOCK 10

STRATA PLAN BCS790
PHASE 2

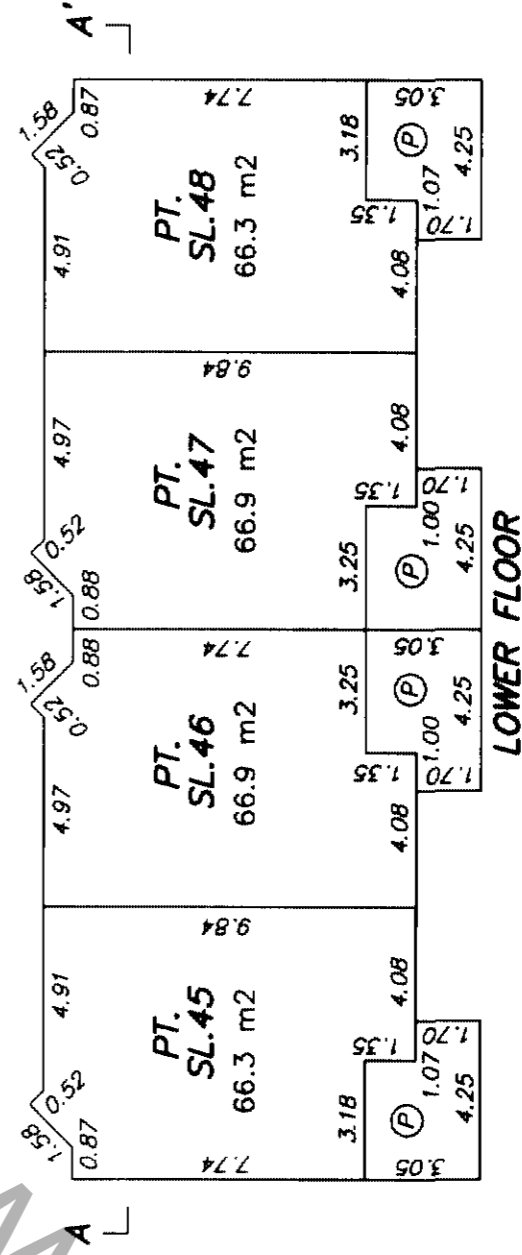
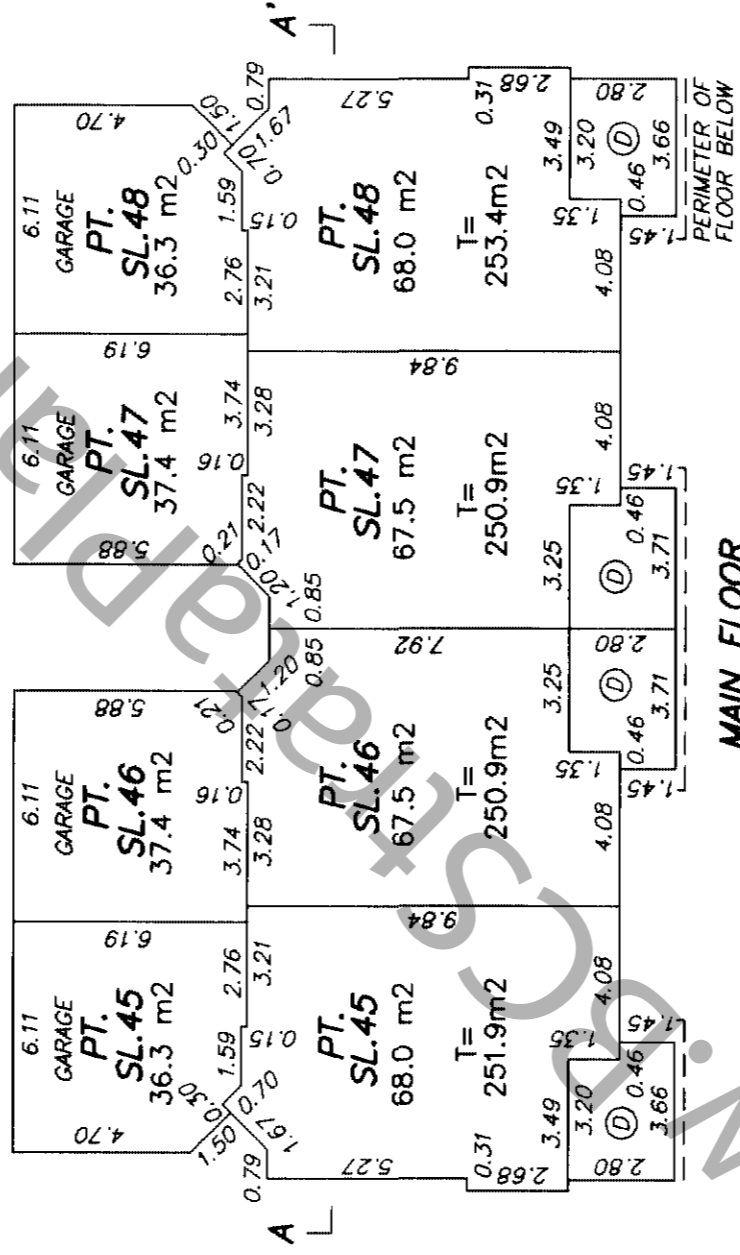
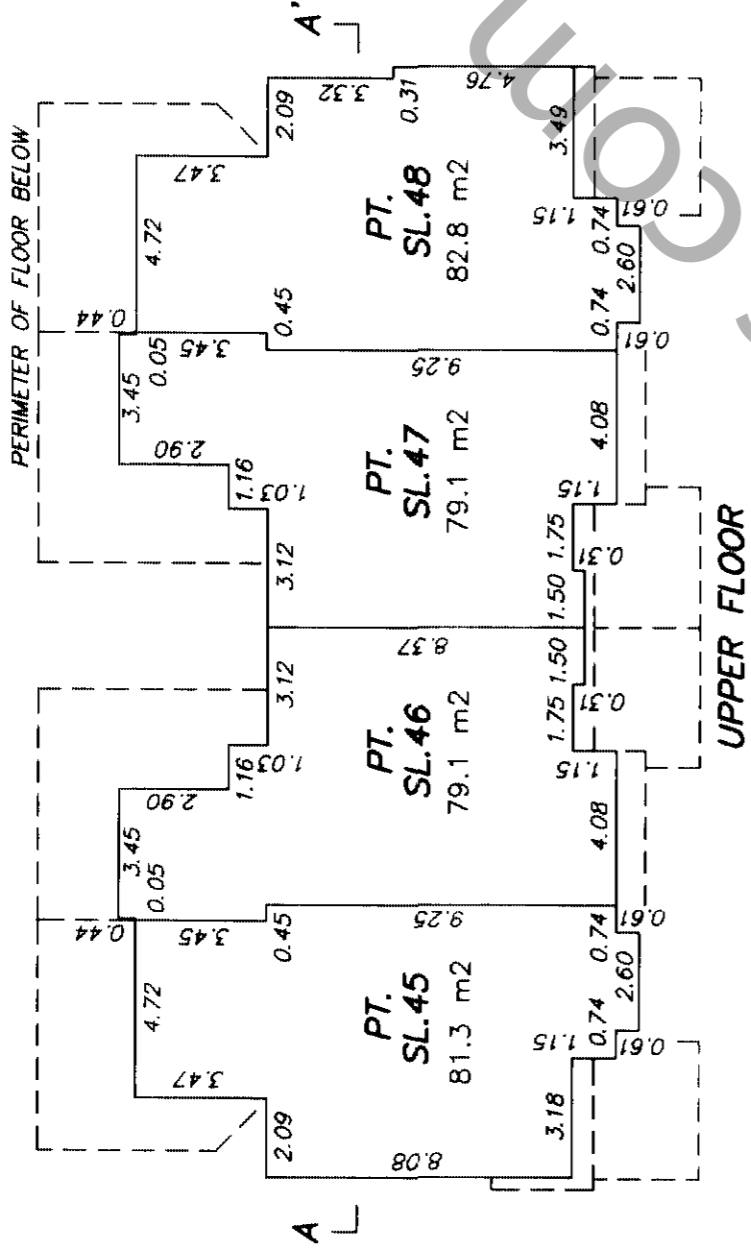
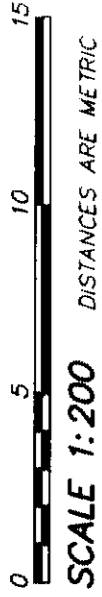

UPPER FLOOR			
MAIN FLOOR	SL.45	SL.46	SL.47
LOWER FLOOR			SL.48

SECTION A-A'

FLOOR PLANS
BLOCK 11

STRATA PLAN BCS790
PHASE 2

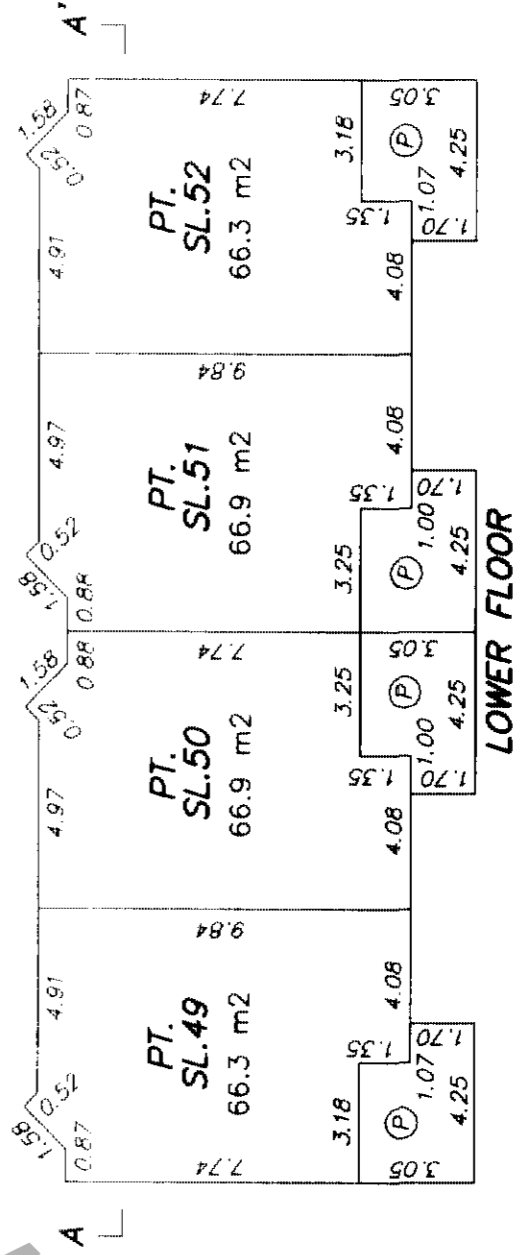
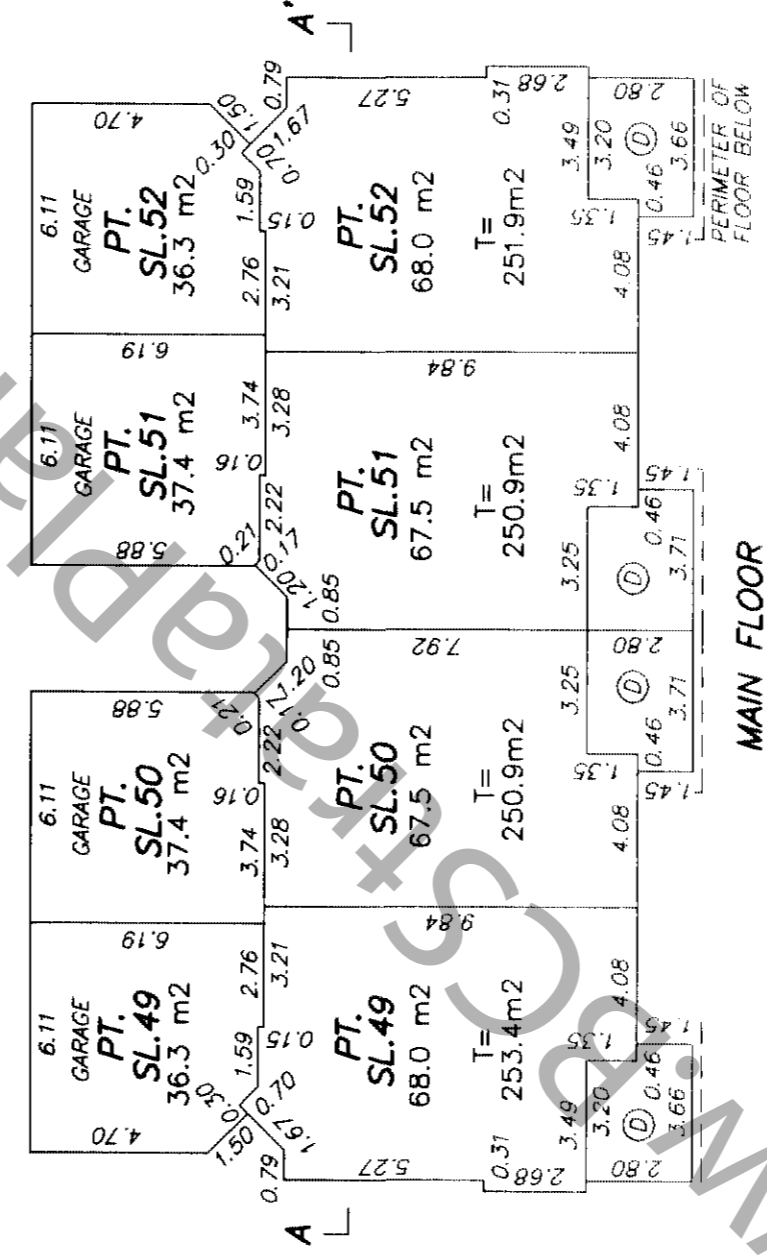
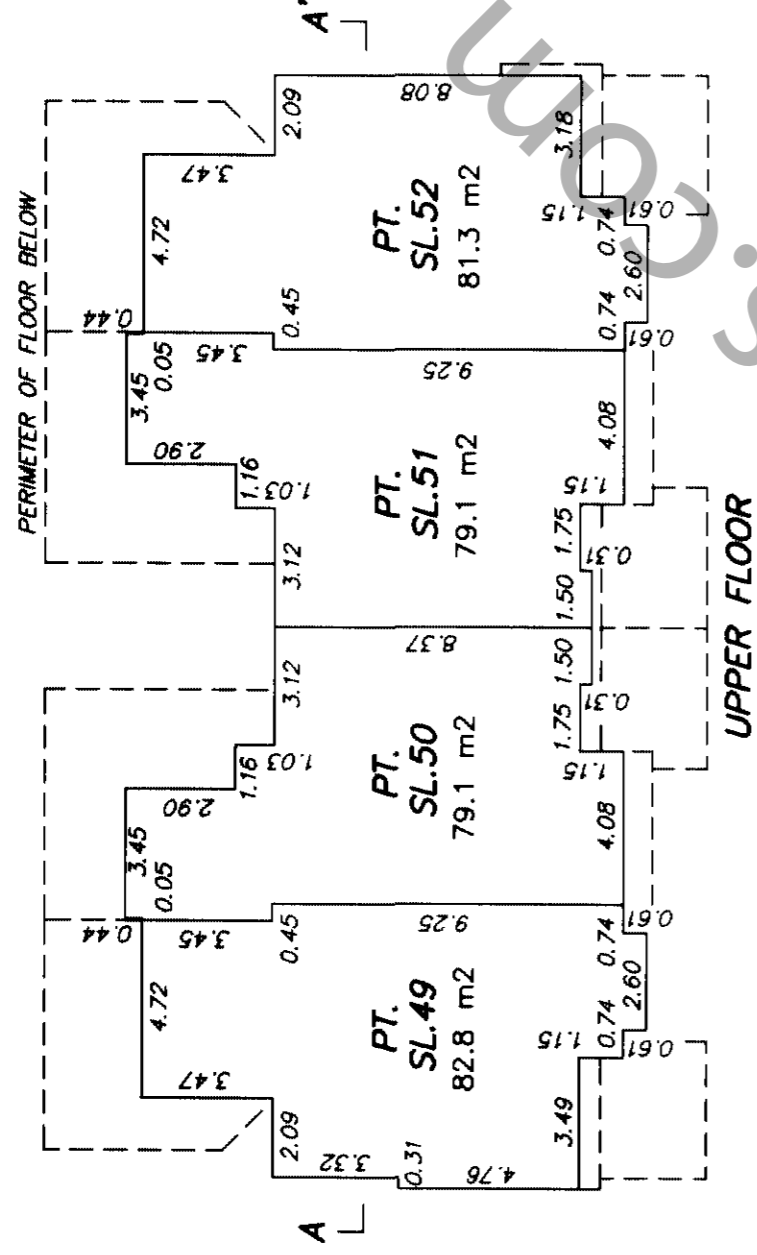

UPPER FLOOR			
MAIN FLOOR	SL.49	SL.50	SL.51
LOWER FLOOR			SL.52

SECTION A-A'

MAY 26, 2004
FILE: 2935-523

FLOOR PLANS
BLOCK 12

STRATA PLAN BCS790
PHASE 2

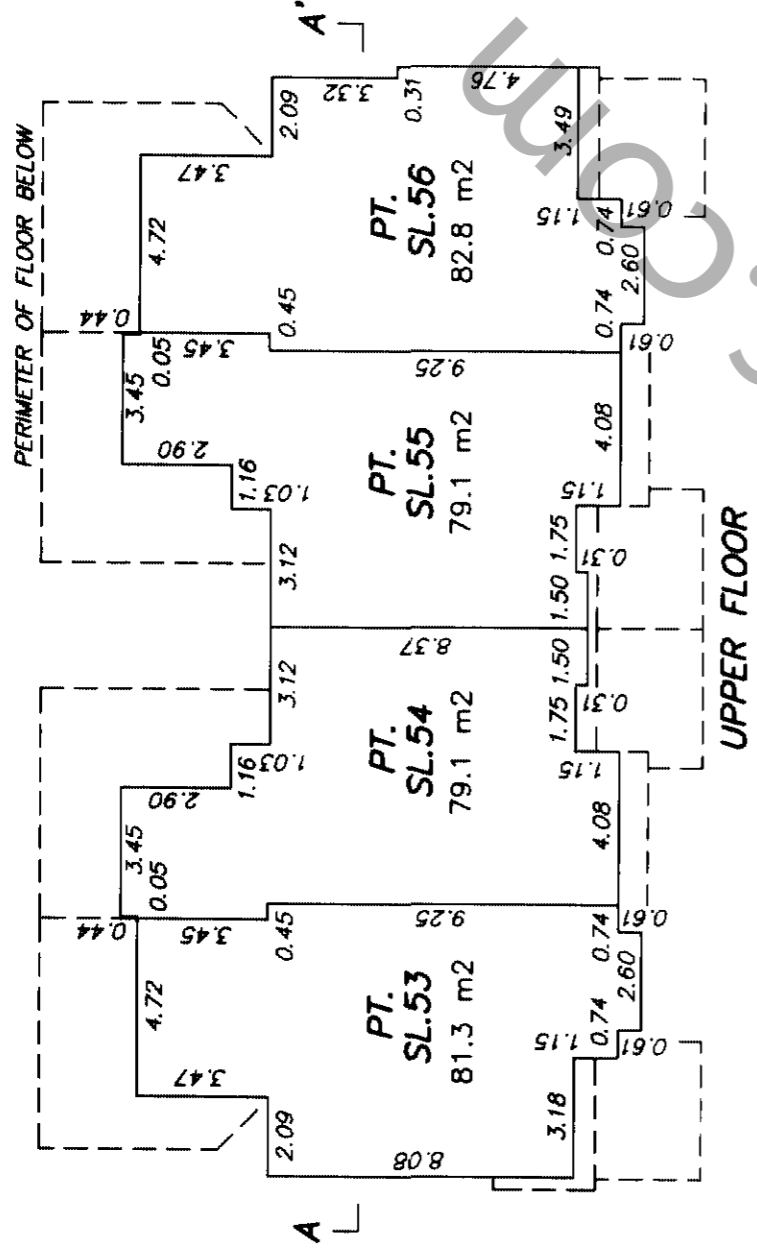
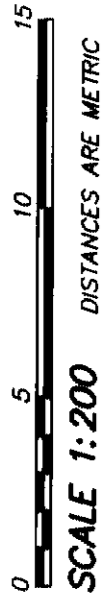
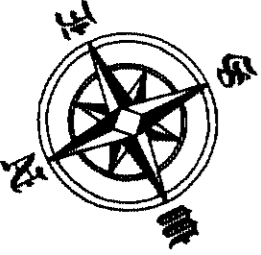

UPPER FLOOR

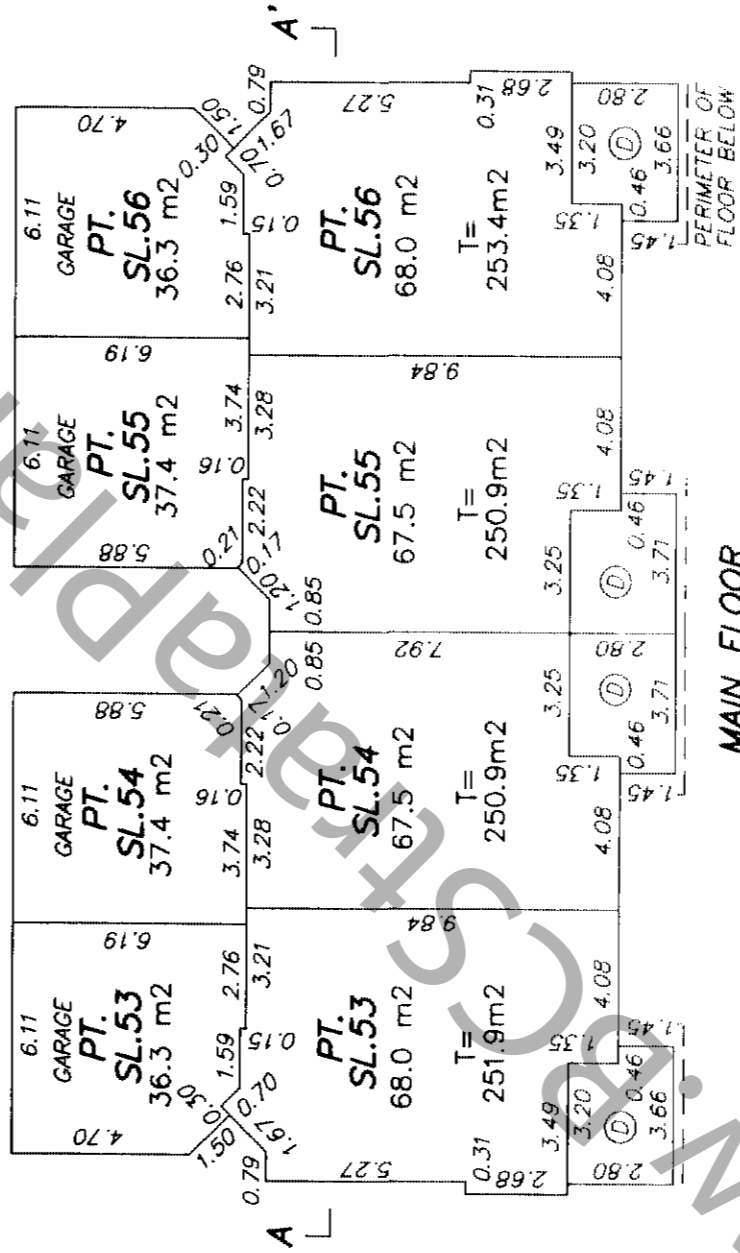

MAIN FLOOR

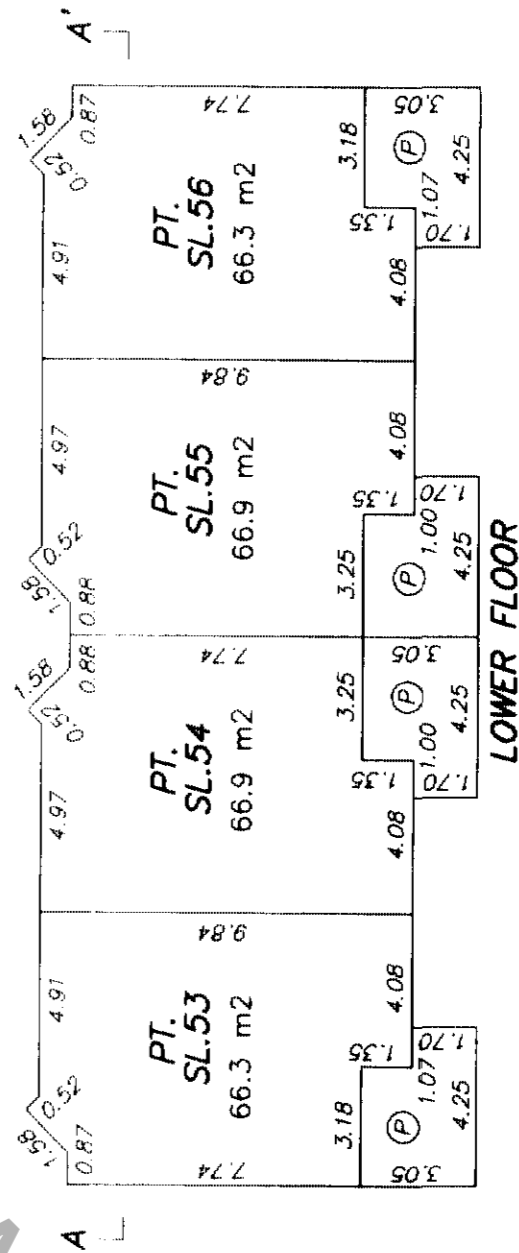

LOWER FLOOR

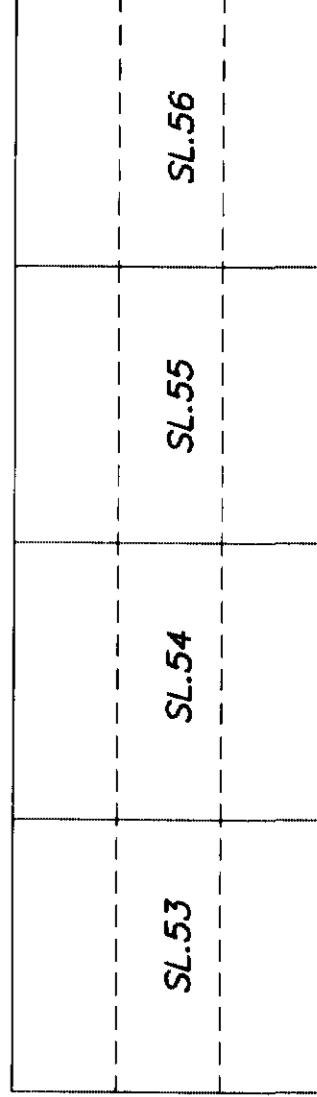

SECTION A-A'

[Signature]
MAY 26, 2004
FILE: 2935-S23

FLOOR PLANS
BLOCK 13

STRATA PLAN BCS790
PHASE 2

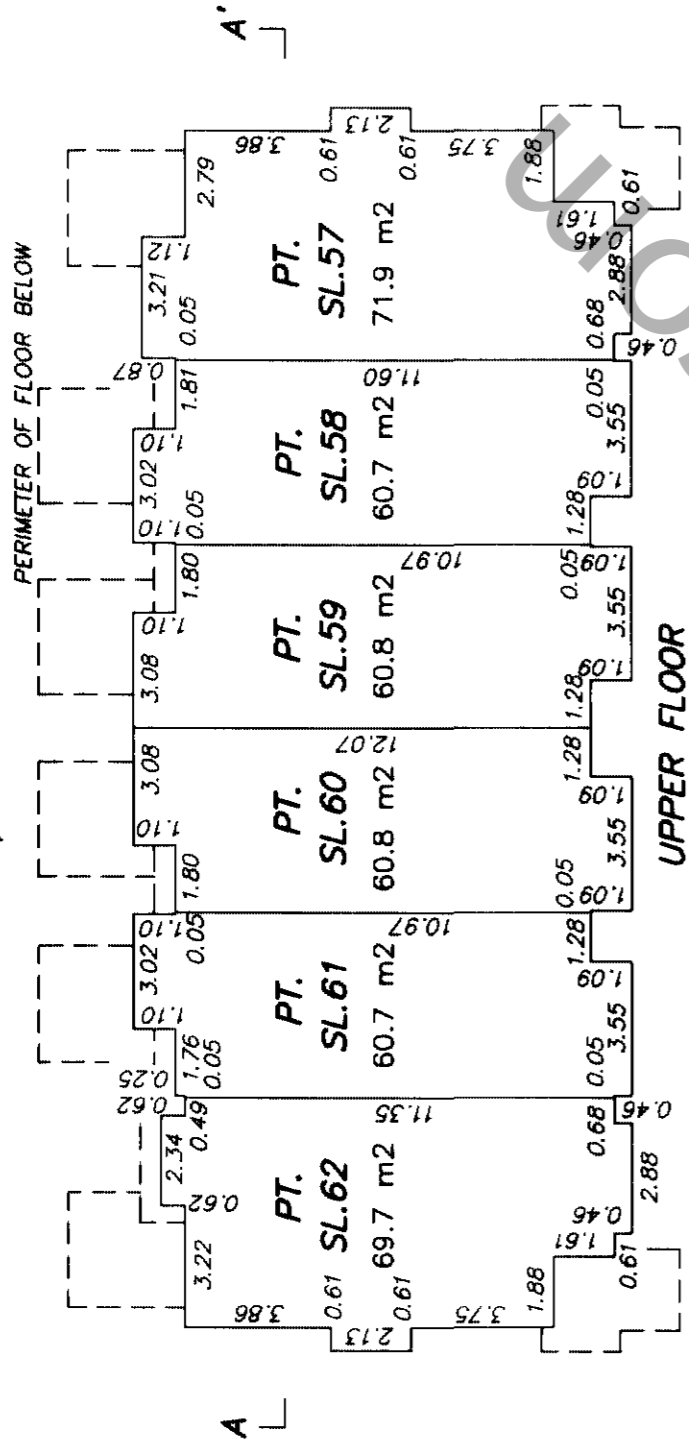

UPPER FLOOR

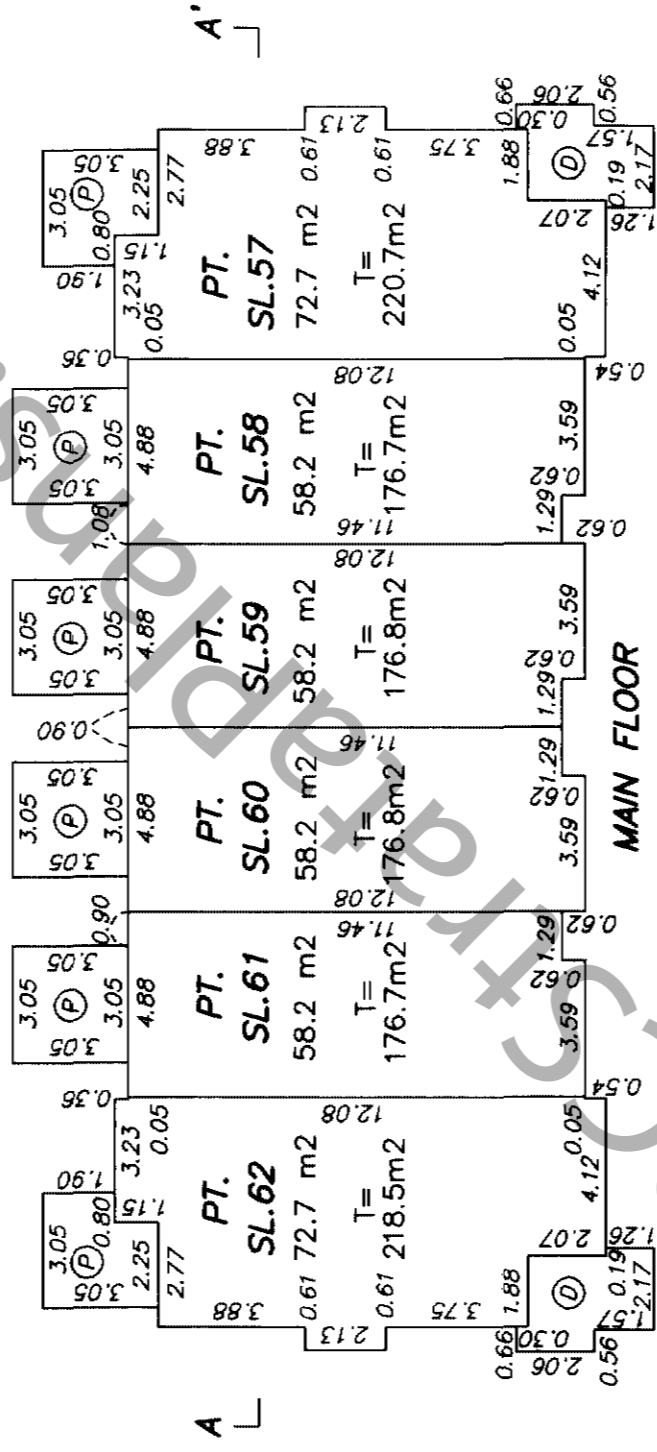

MAIN FLOOR

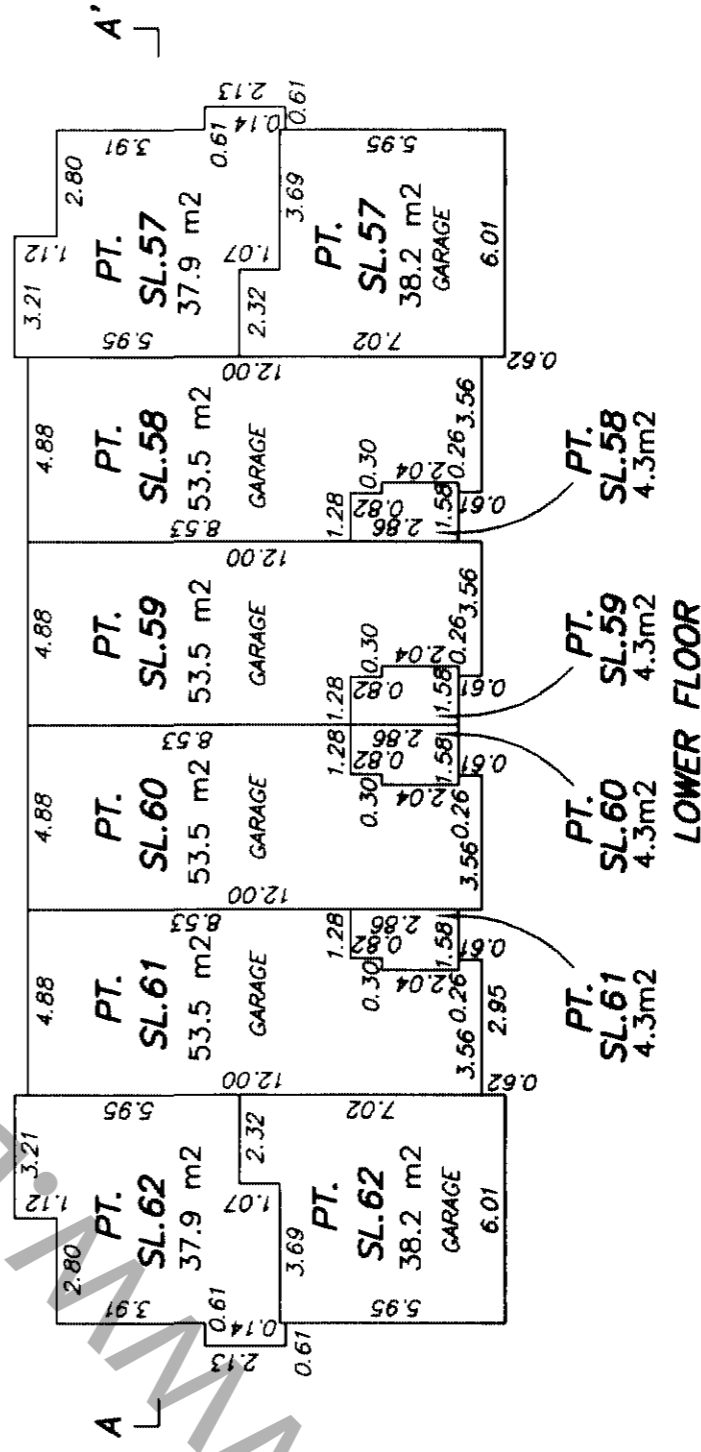

LOWER FLOOR

UPPER FLOOR								
MAIN FLOOR	SL.62	SL.61	SL.60	SL.59	SL.58	SL.57		
LOWER FLOOR			GARAGE	GARAGE	GARAGE			

SECTION A-A'

[Signature]
MAY 26, 2004
FILE: 2935-523

FLOOR PLANS
BLOCK 14

STRATA PLAN BCS790
PHASE 2

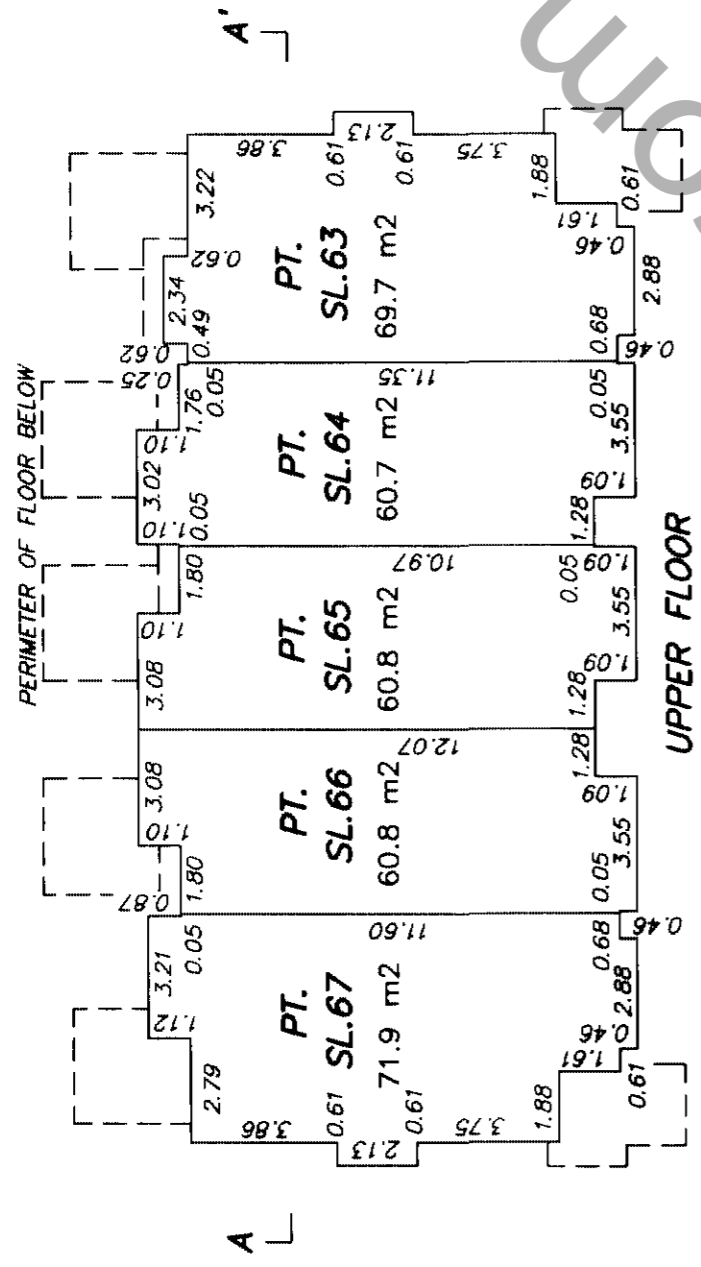

UPPER FLOOR

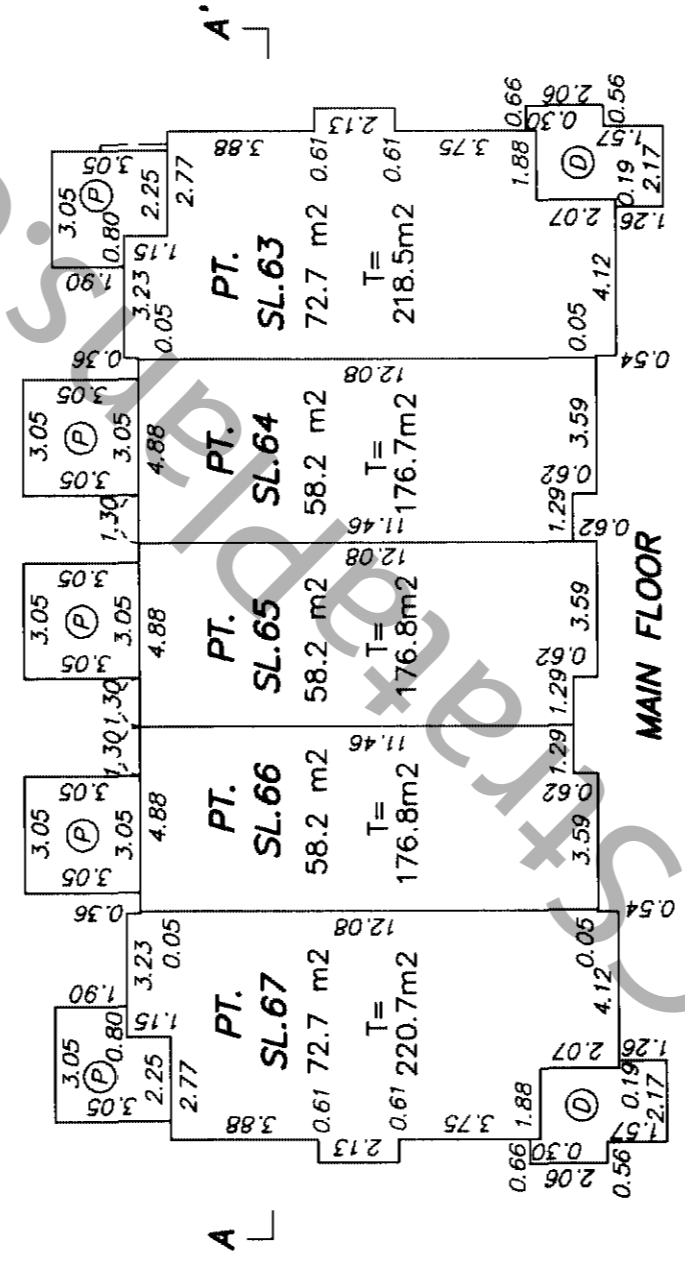

MAIN FLOOR

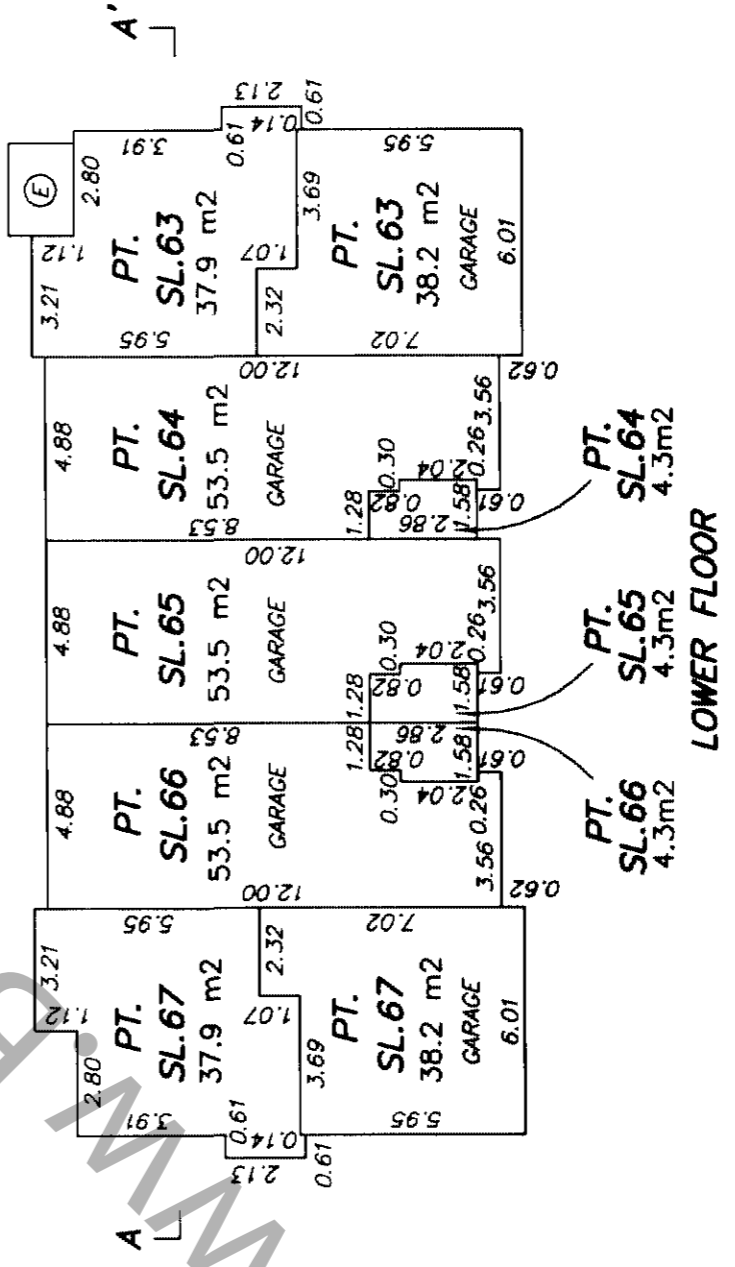

LOWER FLOOR

UPPER FLOOR					
MAIN FLOOR	SL.67	SL.66	SL.65	SL.64	SL.63
LOWER FLOOR		GARAGE	GARAGE	GARAGE	

SECTION A-A'

[Signature]
MAY 26, 2004
FILE: 2935-S23

FLOOR PLANS
BLOCK 16

STRATA PLAN BCS790
PHASE 2

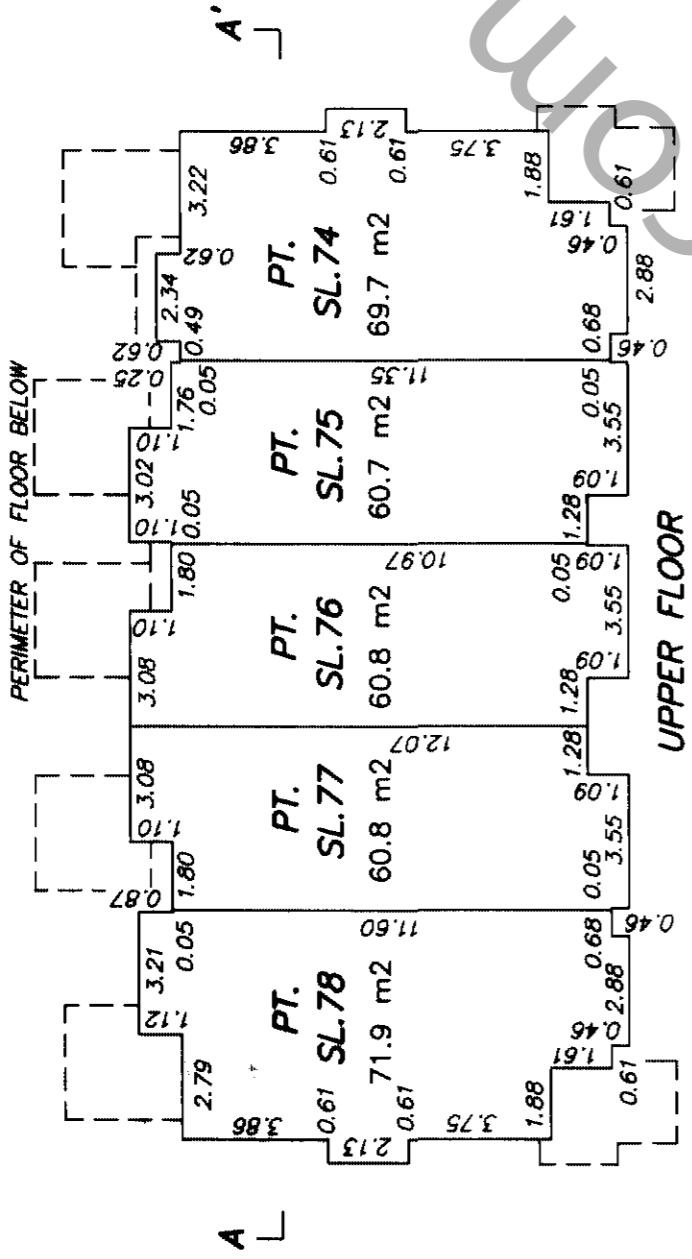

UPPER FLOOR

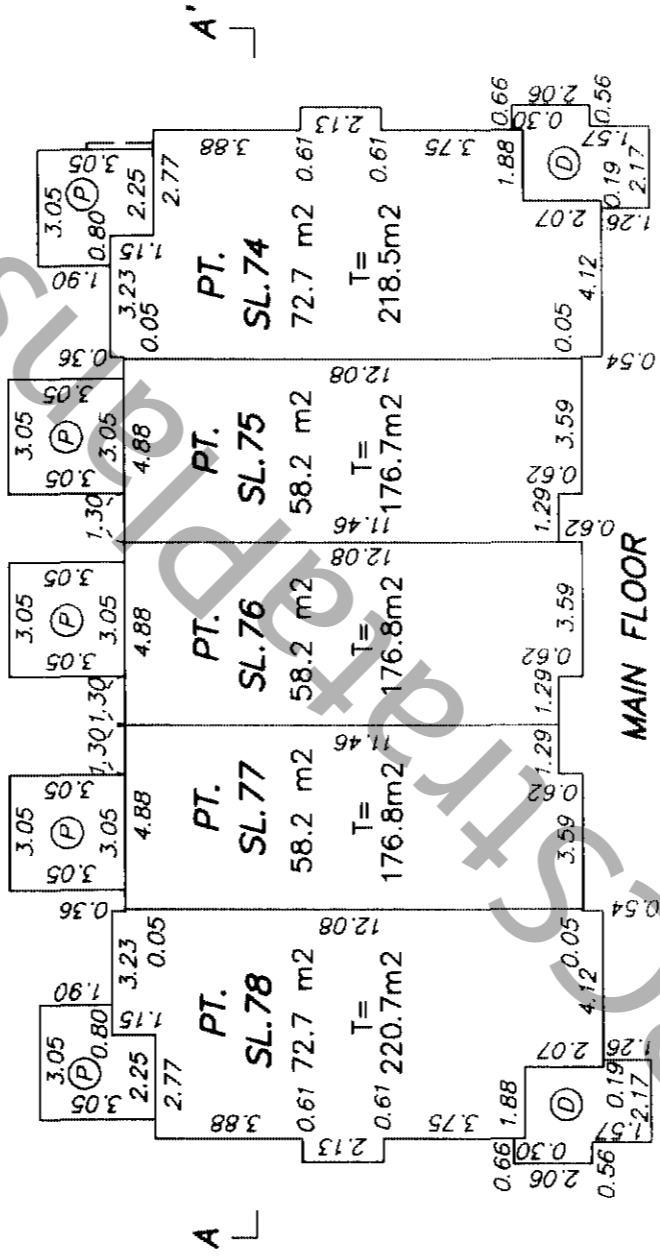

MAIN FLOOR

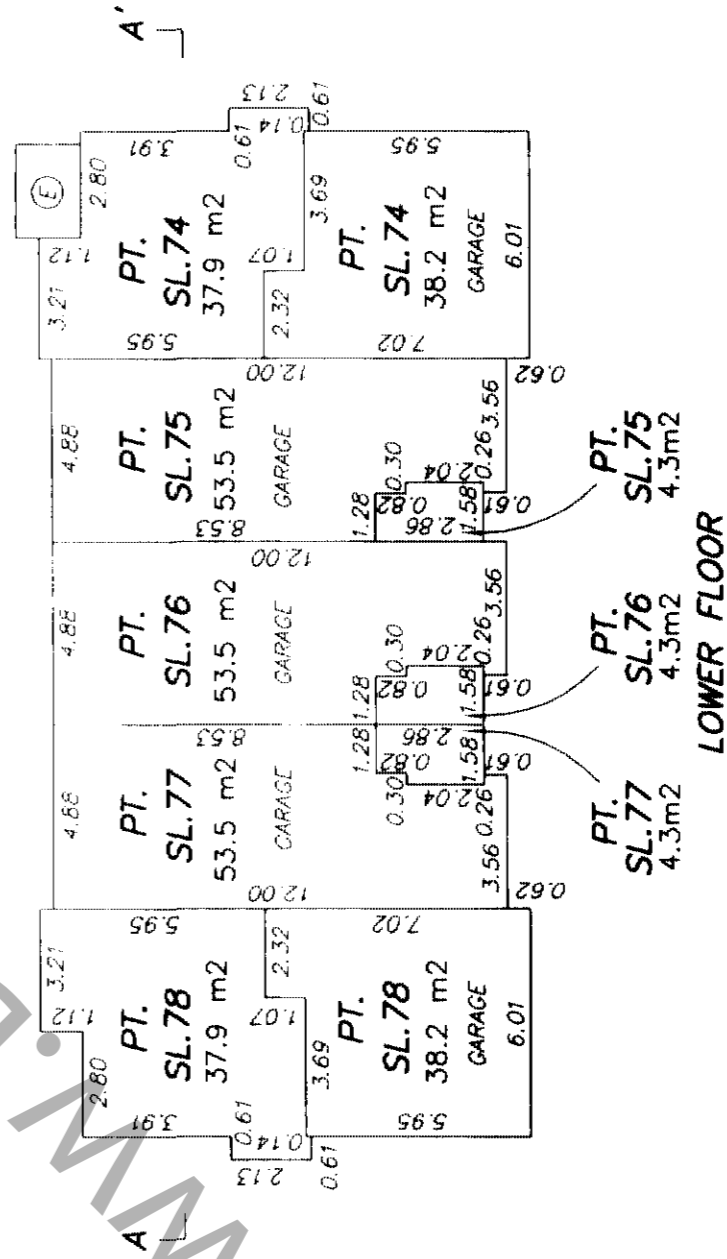

LOWER FLOOR

UPPER FLOOR					
MAIN FLOOR	SL.78	SL.77	SL.76	SL.75	SL.74
LOWER FLOOR		GARAGE	GARAGE	GARAGE	

SECTION A-A'

MAY 26, 2004
FILE: 2935-S23